



Document Title	HSD110PHW2-A Product Information	Page No.	1/24
Document No.		Revision	1.3

TO :

Date : Mar., 27, 2009

HannStar Product Information **(Preliminary)**

Model: HSD110PHW2
-A**

- Note: (1) The information contained herein is tentative and may be changed without prior notices
- (2) Please contact HannStar Display Corp. before designing your product based on this module specification.
- (3) The information contained herein is presented merely to indicate the characteristics and performance of our products. No responsibility is assumed by HannStar for any intellectual property claims or other problems that may result from application based on the module described herein.
- (4) The mark “ ** ” of Model means sub-model code.



Document Title	HSD110PHW2-A Product Information	Page No.	2/24
Document No.		Revision	1.3

Record of Revisions

Rev.	Date	Sub-Model	Description of change
1.3	Mar, 27, 2009	A**	Preliminary Product Information was first released.



Document Title	HSD110PHW2-A Product Information	Page No.	3/24
Document No.		Revision	1.3

Contents

1.0	General description	p.4
2.0	Absolute maximum ratings.....	p.5
3.0	Optical characteristics.....	p.6
4.0	Block diagram	p.10
5.0	Interface pin connection	p.12
6.0	Electrical characteristics	p.14
7.0	Reliability test items	p.19
8.0	Outline dimension	p.20
9.0	Lot mark	p.22
10.0	Package specification	p.23
11.0	General precaution	p.24



Document Title	HSD110PHW2-A Product Information	Page No.	4/24
Document No.		Revision	1.3

1.0 GENERAL DESCRIPTION

1.1 Introduction

HannStar Display model HSD110PHW2-A is a color active matrix thin film transistor (TFT) liquid crystal display (LCD) that uses amorphous silicon TFT as a switching device. This model is composed of a TFT LCD panel, a driving circuit and a back light system. This TFT LCD has a 16 (16:9) inch diagonally measured active display area with HD (1366 horizontal by 768 vertical pixel) resolution.

1.2 Features

- 11 (16:9 diagonal) inch configuration
- One channel LVDS interface
- 262K color by 6 bit R.G.B signal input
- RoHS Compliance
- Halogen Free
- Color Engine
- DBC

1.3 Applications

- NB

1.4 General information

Item	Specification	Unit	
Outline Dimension	254.6(Typ) x 161.3(Typ) x 3.6 (Max.)	mm	
Display area	243.63(H) x 136.97(V)	mm	
Number of Pixel	1366 RGB (H) x 768(V)	pixels	
Pixel pitch	0.1784(H) x 0.1784(V)	mm	
Pixel arrangement	RGB Vertical stripe		
Display mode	Normally white		
NTSC	50	%	
Surface treatment	AG, Hard-Coating (3H)		
Weight	(220) (Typ.)	g	
Back-light	White LED		
Power Consumption	Logic System	(1.2W) (Max.)	W
	B/L System	(2.95W) (Max.)	W

Document Title	HSD110PHW2-A Product Information	Page No.	5/24
Document No.		Revision	1.3

1.5 Mechanical Information

Item		Min.	Typ.	Max.	Unit
Module Size	Horizontal (H)	254.1	254.6	255.1	mm
	Vertical (V)	160.8	161.3	161.8	mm
	Depth (D)	—	—	(3.6)	mm
Weight		—	(220)	(230)	g

2.0 ABSOLUTE MAXIMUM RATINGS

2.1 Electrical Absolute Rating

2.1.1 TFT LCD Module

Item	Symbol	Min.	Max.	Unit	Note
Logic Supply voltage	V_{DD}	-0.3	6.0	V	

2.1.2 Environment Absolute Rating

Item	Symbol	Min.	Max.	Unit	Note
Operating Temperature	T_{opa}	0	50	°C	
Storage Temperature	T_{stg}	-20	60	°C	

Document Title	HSD110PHW2-A Product Information	Page No.	6/24
Document No.		Revision	1.3

3.0 OPTICAL CHARACTERISTICS

3.1 Optical specification

Item		Symbol	Condition	Min.	Typ.	Max.	Unit	Note
Contrast		CR	$\Theta=0$ Normal viewing angle	—	(500)	—		(1)(2)(4)
Response time		RT		—	(8)	—	msec	(1)(3)
White luminance (5 point)		Y_L		—	(200)	—	cd/m ²	(1)(4)(5) ($I_L=220mA$)
Color chromaticity (CIE1931)	Red	R_x		—	(TBD)	—		
		R_y		—	(TBD)	—		
	Green	G_x		—	(TBD)	—		
		G_y		—	(TBD)	—		
	Blue	B_x		—	(TBD)	—		
		B_y		—	(TBD)	—		
	White	W_x		0.283	0.313	0.343		
		W_y	0.299	0.329	0.359			
Viewing angle	Hor.	Θ_L	CR>10	—	45	—		(1)(4)
		Θ_R		—	45	—		
	Ver.	Θ_U		—	15	—		
		Θ_D		—	35	—		
Brightness uniformity		B_{UNI}	$\Theta=0$ (5point)	80	—	—	%	(6)
Brightness Uniformity		B_{UNI}	$\Theta=0$ (13 points)	70	—	—	%	(6)

3.2 Measuring Condition

- Measuring surrounding : dark room
- LED Current I_L : 220mA
- Ambient temperature : $25\pm 2^\circ C$
- 15min. warm-up time.

Document Title	HSD110PHW2-A Product Information	Page No.	7/24
Document No.		Revision	1.3

3.3 Measuring Equipment

- FPM520 of Westar Display technologies, INC., which utilized SR-3 for Chromaticity and BM-5A for other optical characteristics.

- Measuring spot size : 20 ~ 21 mm

Note (1) Definition of Viewing Angle:

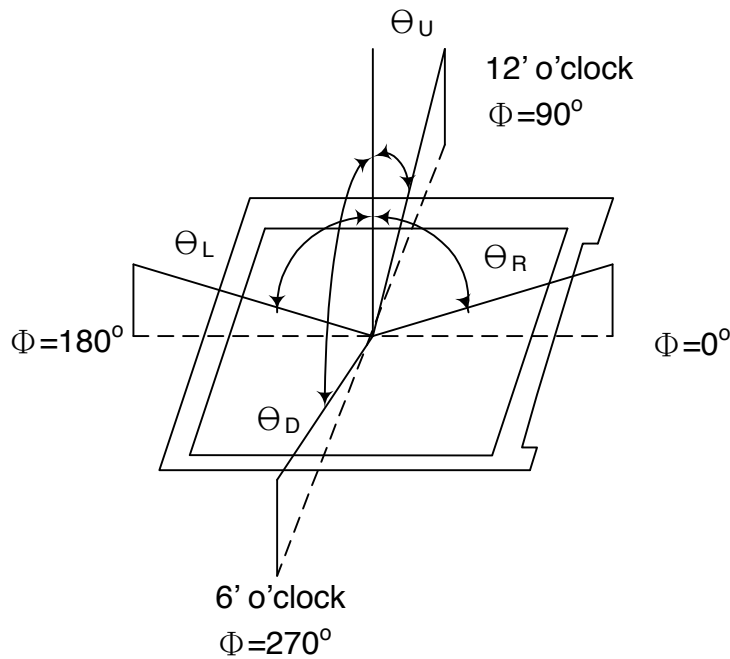

Note (2) Definition of Contrast Ratio (CR) :
measured at the center point of panel

$$CR = \frac{\text{Luminance with all pixels white}}{\text{Luminance with all pixels black}}$$

Document Title	HSD110PHW2-A Product Information	Page No.	8/24
Document No.		Revision	1.3

Note (3) Definition of Response Time : Sum of T_R and T_F

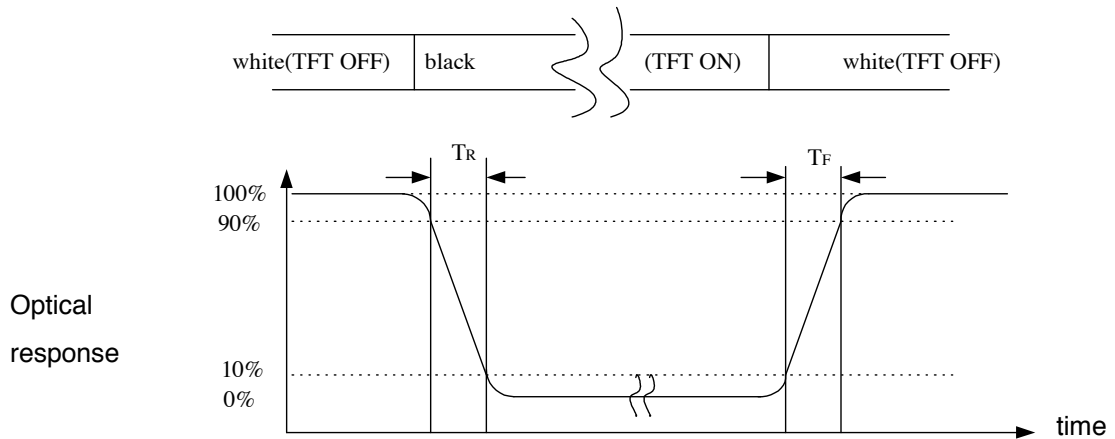

Note (4) Definition of optical measurement setup

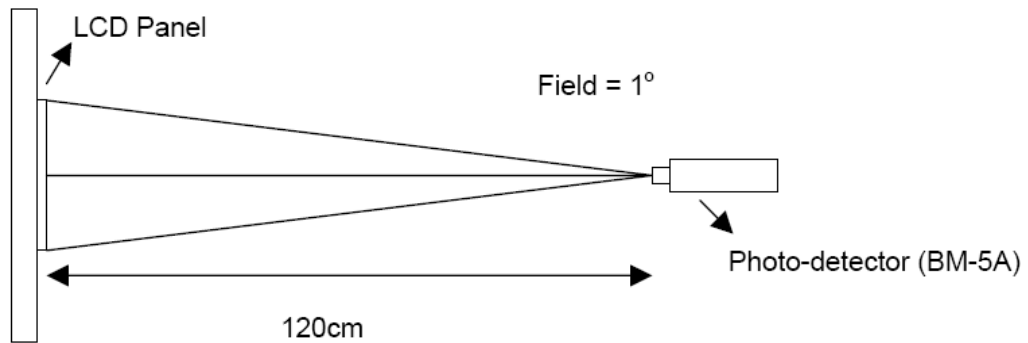

Document Title	HSD110PHW2-A Product Information	Page No.	9/24
Document No.		Revision	1.3

Note (5) Definition of Average Luminance Uniformity of White (5 Point)

$$\text{Average Luminance Uniformity} = \frac{Y_1+Y_2+Y_3+Y_4+Y_5}{5}$$

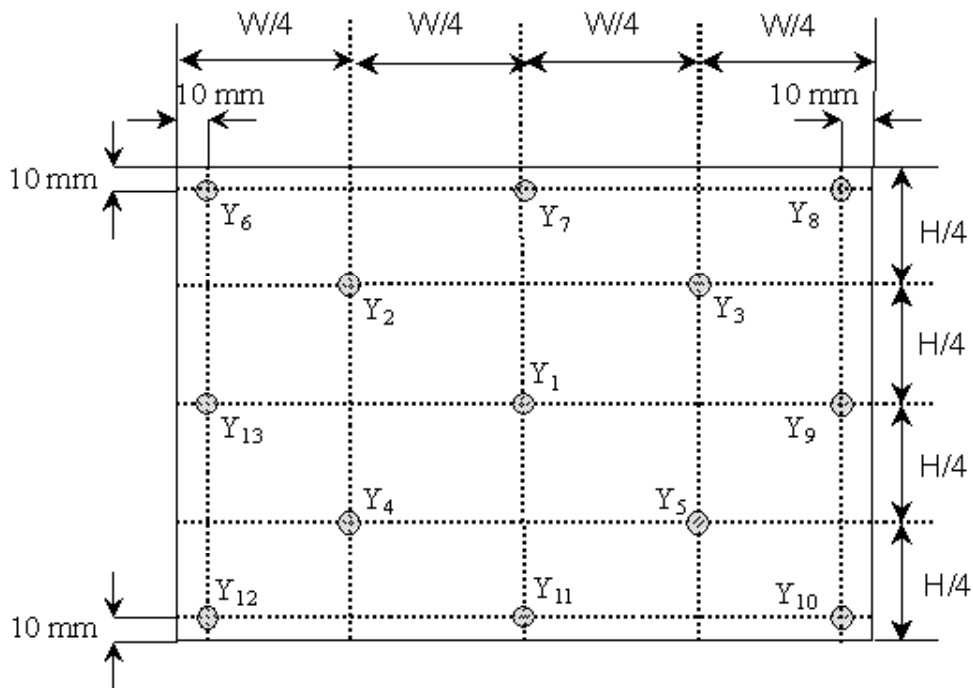

Note (6) Definition of brightness uniformity

$$\text{Luminance uniformity(5 points)} = \frac{(\text{Min Luminance of 5 points})}{(\text{Max Luminance of 5 points})} \times 100\%$$

$$\text{Luminance uniformity(13points)} = \frac{(\text{Min Luminance of 13 points})}{(\text{Max Luminance of 13 points})} \times 100\%$$

Document Title	HSD110PHW2-A Product Information	Page No.	10/24
Document No.		Revision	1.3

4.0 BLOCK DIAGRAM

4.1 TFT LCD Module:

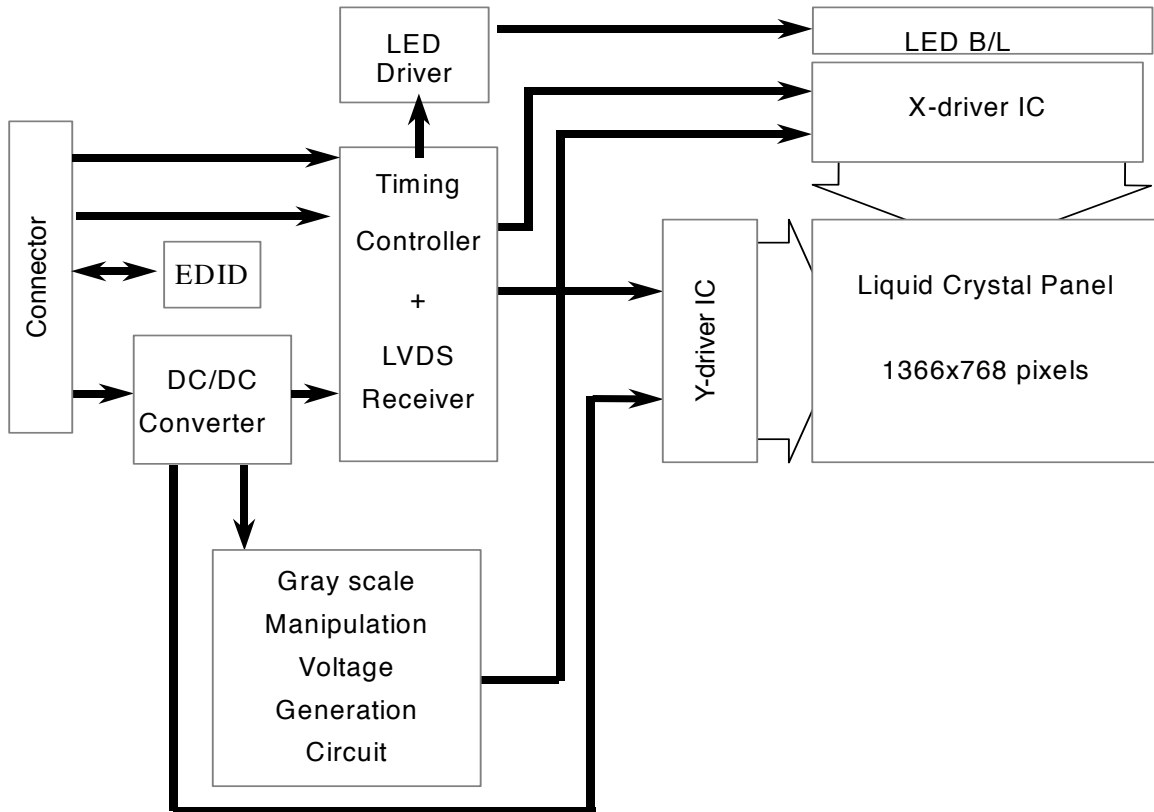

4.2 Pixel Format

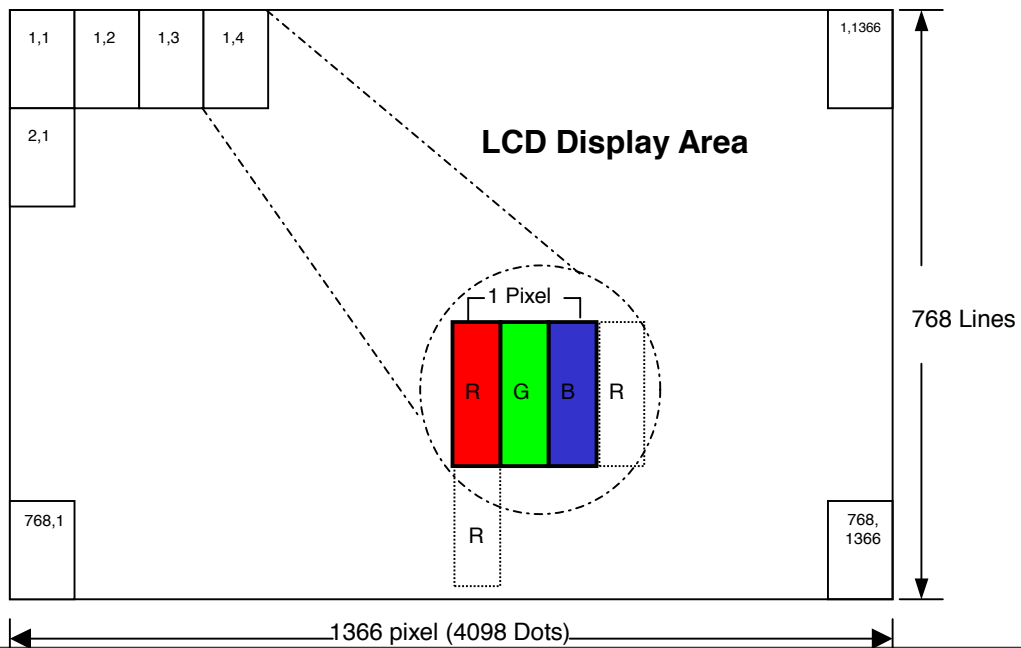

Document Title	HSD110PHW2-A Product Information	Page No.	11/24
Document No.		Revision	1.3

4.3 Relationship Between Displayed Color and Input

Display	MSB						LSB						MSB						LSB						Gray scale level
	R5	R4	R3	R2	R1	R0	G5	G4	G3	G2	G1	G0	B5	B4	B3	B2	B1	B0							
Basic color	Black	L	L	L	L	L	L	L	L	L	L	L	L	L	L	L	L	L	L	-					
	Blue	L	L	L	L	L	L	L	L	L	L	L	L	H	H	H	H	H	H	-					
	Green	L	L	L	L	L	L	H	H	H	H	H	H	L	L	L	L	L	L	-					
	Light Blue	L	L	L	L	L	L	H	H	H	H	H	H	H	H	H	H	H	H	-					
	Red	H	H	H	H	H	H	L	L	L	L	L	L	L	L	L	L	L	L	-					
	Purple	H	H	H	H	H	H	L	L	L	L	L	L	H	H	H	H	H	H	-					
	Yellow	H	H	H	H	H	H	H	H	H	H	H	H	L	L	L	L	L	L	-					
	White	H	H	H	H	H	H	H	H	H	H	H	H	H	H	H	H	H	H	-					
Gray scale of Red	Black	L	L	L	L	L	L	L	L	L	L	L	L	L	L	L	L	L	L	L0					
	Dark ↑ ↓ Light	L	L	L	L	L	H	L	L	L	L	L	L	L	L	L	L	L	L	L1					
		L	L	L	L	L	H	L	L	L	L	L	L	L	L	L	L	L	L	L2					
		⋮	⋮	⋮	⋮	⋮	⋮	⋮	⋮	⋮	⋮	⋮	⋮	⋮	⋮	⋮	⋮	⋮	⋮	⋮	L3...L60				
		H	H	H	H	L	H	L	L	L	L	L	L	L	L	L	L	L	L	L61					
		H	H	H	H	H	L	L	L	L	L	L	L	L	L	L	L	L	L	L62					
	Red	H	H	H	H	H	H	L	L	L	L	L	L	L	L	L	L	L	L	Red L63					
	Gray scale of Green	Black	L	L	L	L	L	L	L	L	L	L	L	L	L	L	L	L	L	L	L0				
Dark ↑ ↓ Light		L	L	L	L	L	L	L	L	L	L	L	H	L	L	L	L	L	L	L1					
		L	L	L	L	L	L	L	L	L	L	L	H	L	L	L	L	L	L	L2					
		⋮	⋮	⋮	⋮	⋮	⋮	⋮	⋮	⋮	⋮	⋮	⋮	⋮	⋮	⋮	⋮	⋮	⋮	⋮	L3...L60				
		L	L	L	L	L	L	H	H	H	H	L	H	L	L	L	L	L	L	L61					
		L	L	L	L	L	L	H	H	H	H	H	L	L	L	L	L	L	L	L62					
Green		L	L	L	L	L	L	H	H	H	H	H	H	L	L	L	L	L	L	Green L63					
Gray scale of Blue		Black	L	L	L	L	L	L	L	L	L	L	L	L	L	L	L	L	L	L	L0				
	Dark ↑ ↓ Light	L	L	L	L	L	L	L	L	L	L	L	L	L	L	L	L	L	H	L1					
		L	L	L	L	L	L	L	L	L	L	L	L	L	L	L	L	H	L	L2					
		⋮	⋮	⋮	⋮	⋮	⋮	⋮	⋮	⋮	⋮	⋮	⋮	⋮	⋮	⋮	⋮	⋮	⋮	⋮	L3...L60				
		L	L	L	L	L	L	L	L	L	L	L	L	H	H	H	H	L	H	L61					
		L	L	L	L	L	L	L	L	L	L	L	L	H	H	H	H	H	L	L62					
	Blue	L	L	L	L	L	L	L	L	L	L	L	L	H	H	H	H	H	H	Blue L63					
	Gray scale of White & Black	Black	L	L	L	L	L	L	L	L	L	L	L	L	L	L	L	L	L	L	L0				
Dark ↑ ↓ Light		L	L	L	L	L	H	L	L	L	L	L	H	L	L	L	L	L	H	L1					
		L	L	L	L	L	H	L	L	L	L	H	L	L	L	L	L	H	L	L2					
		⋮	⋮	⋮	⋮	⋮	⋮	⋮	⋮	⋮	⋮	⋮	⋮	⋮	⋮	⋮	⋮	⋮	⋮	⋮	L3...L60				
		H	H	H	H	L	H	H	H	H	H	L	H	H	H	H	H	L	H	L61					
		H	H	H	H	H	L	H	H	H	H	H	L	H	H	H	H	H	L	L62					
White		H	H	H	H	H	H	H	H	H	H	H	H	H	H	H	H	H	H	White L63					

Document Title	HSD110PHW2-A Product Information	Page No.	12/24
Document No.		Revision	1.3

5.0 INTERFACE PIN CONNECTION

5.1 TFT LCD Module : CN1 (Input signal): IPEX 20347-330E-12 (IPEX or equivalent)

Pin No.	Signal	Description
1	GND	Ground
2	VDD	3.3V Power
3	VDD	3.3V Power
4	V_EDID	3.3V Power for EDID
5	LED PWM	Adjust for LED brightness Note 1
6	CLK_EDID	EDID Clock Input
7	DATA_EDID	EDID Data Input
8	RXIN0-	LVDS Signal - channel0-
9	RXIN0+	LVDS Signal+ channel0+
10	GND	Ground
11	RXIN1-	Data Input channel1-
12	RXIN1+	Data Input channel1+
13	GND	Ground
14	RXIN2-	Data Input channel2-
15	RXIN2+	Data Input channel2+
16	GND	Ground
17	RXCLKIN-	Data Input CLK-
18	RXCLKIN+	Data Input CLK+
19	GND	Ground
20	NC	NC
21	NC	NC
22	GND	Ground
23	GND	Ground
24	VLED	LED Power +5V
25	VLED	LED Power +5V
26	VLED	LED Power +5V
27	NC	NC
28	DBC_EN	Dynamic backlight function enable/disable
29	COLOR_EN	Color Engine Enable/ disable
30	NC	NC

Note 1 : The brightness of LCD panel could be changed by adjusting PWM

Document Title	HSD110PHW2-A Product Information	Page No.	13/24
Document No.		Revision	1.3

Note 2 : PWM =0~3.3V , Operation Frequency :

Parameter	Symbol	Min	Typ	Max	Units	Remark
PWM Frequency	F_{PWM}	18	--	22	KHz	
PWM Duty Cycle	T_D	20	--	100	%	

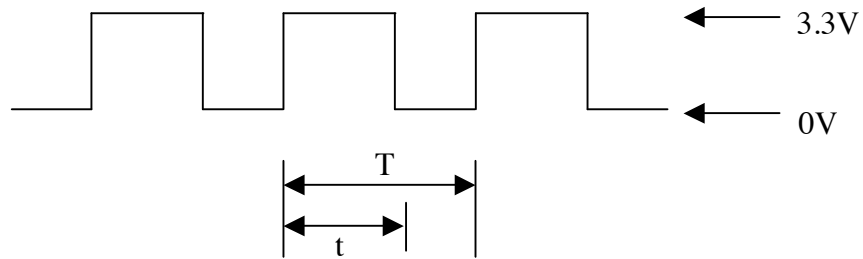

$$\text{Duty Cycle } T_D = (t / T) \times 100\%$$

Document Title	HSD110PHW2-A Product Information	Page No.	14/24
Document No.		Revision	1.3

6.0 ELECTRICAL CHARACTERISTICS

6.1 TFT LCD Module

Item	Symbol	Min.	Typ.	Max.	Unit	Note
Supply Voltage	V_{DD}	3.0	3.3	3.6	V	Note (1)
	V_{LED}	4.7	5.0	5.3	V	
Current of power supply	I_{DD}	-	0.3	-	A	$V_{DD} = 3.3V$ · L0 pattern $T_a = 25^\circ C$ $f_v = 60Hz$
Inrush current	I_{RUSH}	-	-	1.50	A	Note (2)

Note (1): V_{DD} -dip condition:

When V_{DD} operating within $2.7V \leq V_{DD} < 3.0V$ · $t_d \leq 10ms$, the display may momentarily become abnormal.

$V_{DD} < 2.7V$, V_{DD} dip condition should also follow the Power On/Off conditions for supply voltage.

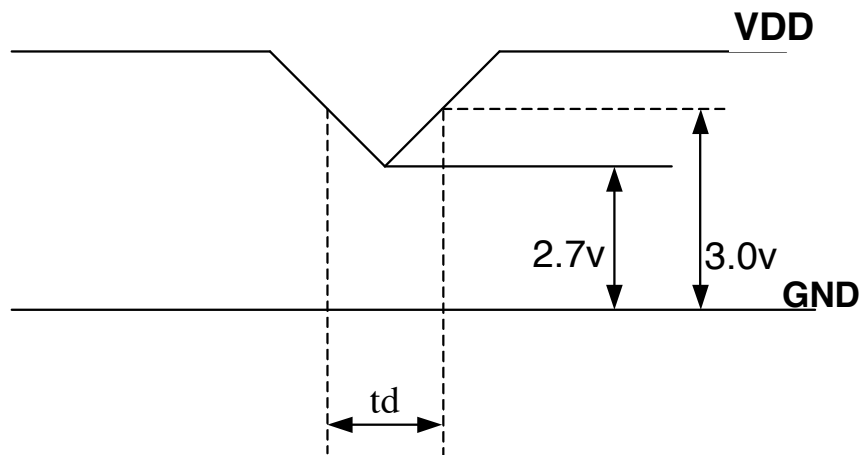

Document Title	HSD110PHW2-A Product Information	Page No.	15/24
Document No.		Revision	1.3

Note : (2) Power on Inrush current test circuit

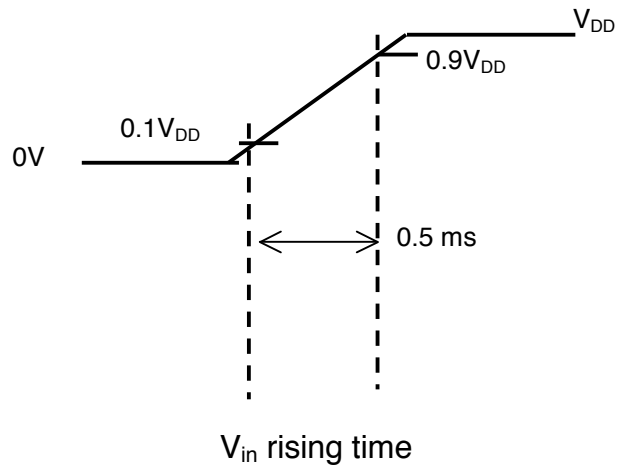
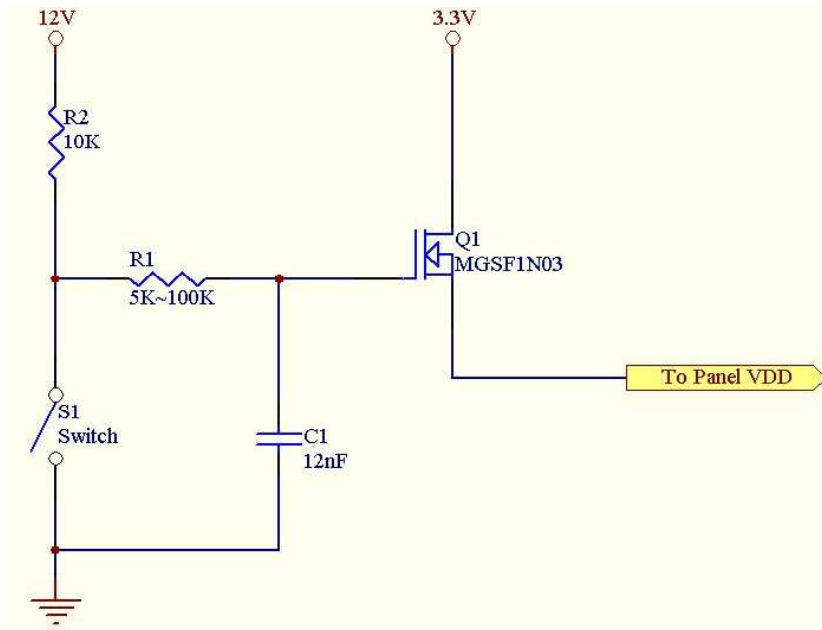

Document Title	HSD110PHW2-A Product Information	Page No.	16/24
Document No.		Revision	1.3

6.2 Switching Characteristics for LVDS Receiver

Item	Symbol	Min.	Typ.	Max.	Unit	Conditions
Differential Input High Threshold	V _{th}	—	—	100	mV	V _{CM} =1.2V
Differential Input Low Threshold	V _{tl}	-100	—	—	mV	
Input Current	I _{IN}	-10	—	+10	uA	
Differential input Voltage	V _{ID}	0.1	—	0.6	V	
Common Mode Voltage Offset	V _{CM}	(V _{ID} /2)	1.25	1.8-0.4-(V _{ID} /2)	V	

6.3 Bit Mapping & Interface Definition

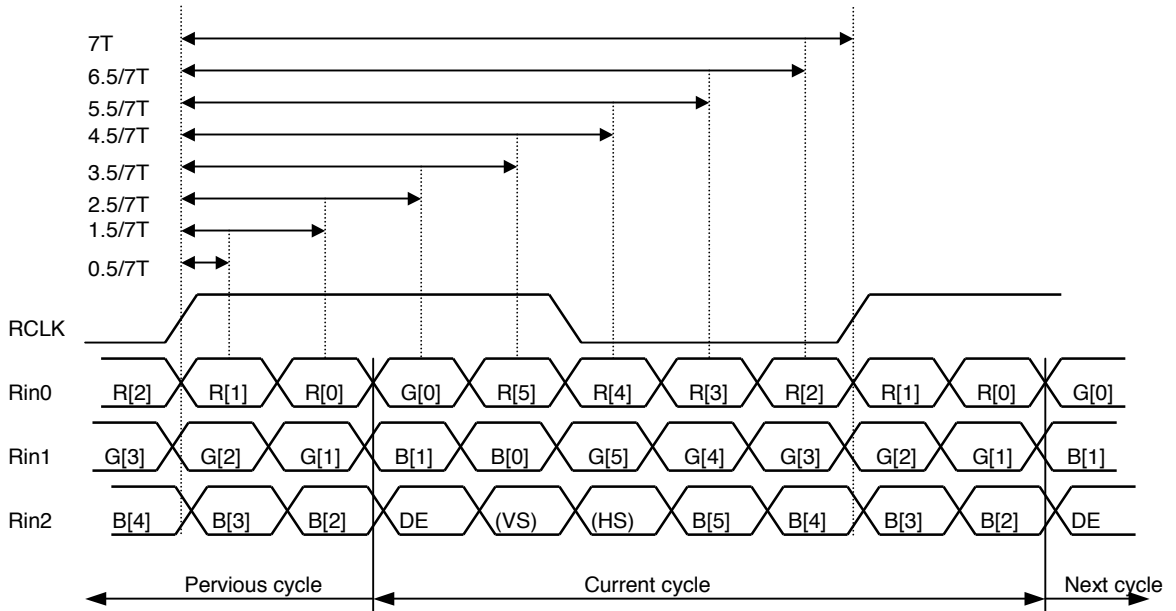

LVDS Receiver Input Timing Definition
for 6bits LVDS input

Document Title	HSD110PHW2-A Product Information	Page No.	17/24
Document No.		Revision	1.3

6.4 Interface Timing (DE mode)

Item	Symbol	Min.	Typ.	Max.	Unit
Frame Rate	--	(55)	(60)	-	Hz
Frame Period	t1	(778)	(806)	(888)	line
Vertical Display Time	t2	(768)	(768)	(768)	line
Vertical Blanking Time	t3	(10)	(38)	(120)	line
1 Line Scanning Time	t4	(1437)	(1560)	(1936)	clock
Horizontal Display Time	t5	(1366)	(1366)	(1366)	clock
Horizontal Blanking Time	t6	(71)	(194)	(570)	clock
Clock Rate	t7	(50.3)	(75.44)	(80)	MHz

Timing Diagram of Interface Signal (DE mode)

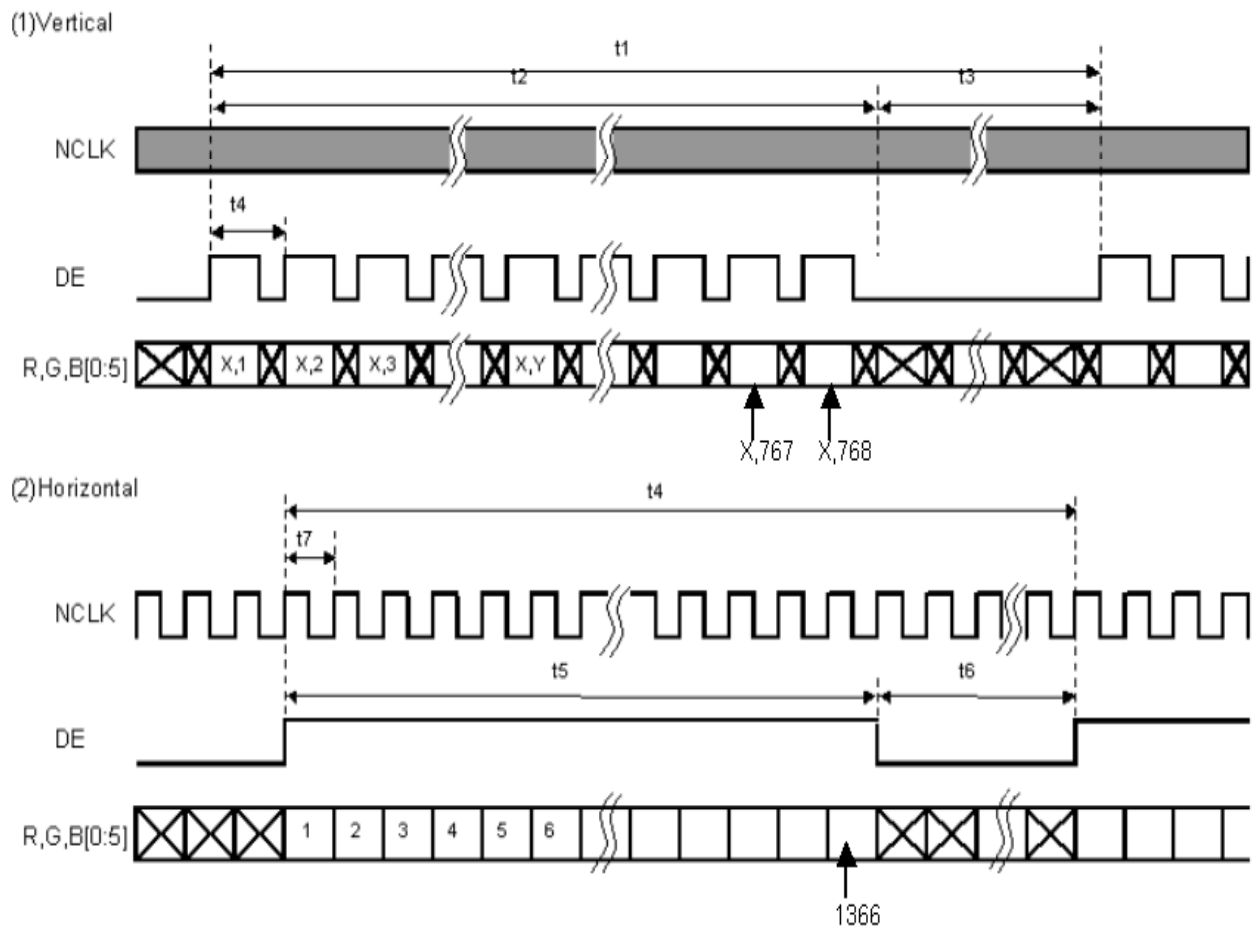

Document Title	HSD110PHW2-A Product Information	Page No.	18/24
Document No.		Revision	1.3

6.5 Power On / Off Sequence

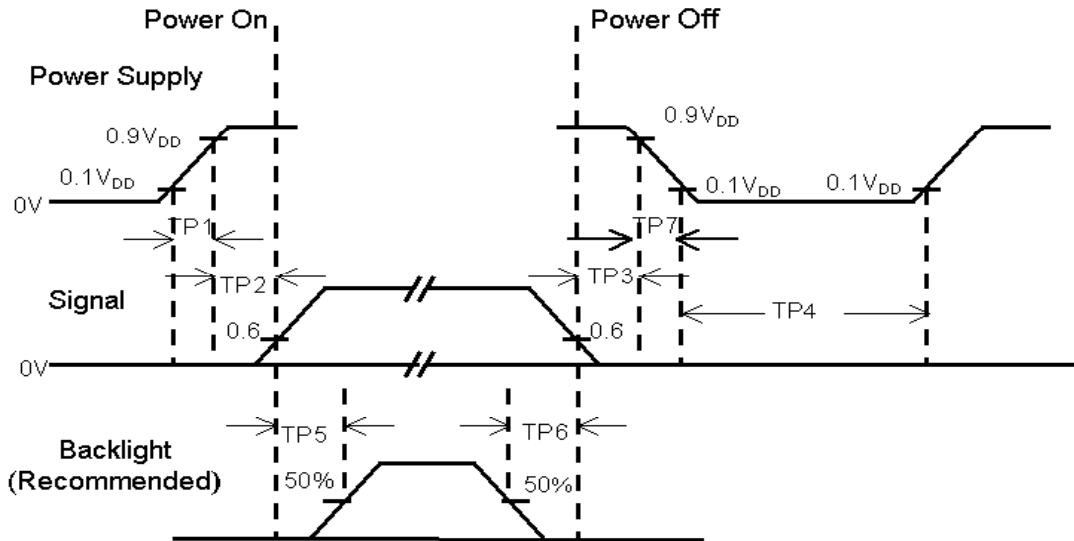

Item	Min.	Typ.	Max.	Unit	Remark
TP1	0.5	--	10	msec	
TP2	0	--	50	msec	
TP3	0	--	50	msec	
TP4	1000	--	--	msec	
TP5	200	--	--	msec	
TP6	200	--	--	msec	
TP7	0.5	--	10	msec	

- Note :**
- (1) The supply voltage of the external system for the module input should be the same as the definition of V_{DD}.
 - (2) Apply the lamp voltage within the LCD operation range. When the back-light turns on before the LCD operation or the LCD turns off before the back-light turns off, the display may momentarily become white.
 - (3) In case of V_{DD} = off level, please keep the level of input signal on the low or keep a high impedance.
 - (4) TP4 should be measured after the module has been fully discharged between power off and on period.
 - (5) Interface signal shall not be kept at high impedance when the power is on.

Document Title	HSD110PHW2-A Product Information	Page No.	19/24
Document No.		Revision	1.3

7.0 Reliability test items

No.	Item	Conditions	Remark
1	High Temperature Storage	Ta=+60°C, 240hrs	
2	Low Temperature Storage	Ta=-20°C, 240hrs	
3	High Temperature Operation	Ta=+50°C, 500hrs	
4	Low Temperature Operation	Ta=0°C, 500hrs	
5	Thermal Cycling Test (non operation)	-20°C(30min)→+60°C(30min),100 cycles	
6	Vibration	Sine Wave 1.5G, 5~500Hz, XYZ 30min/each direction	
7	Shock	Half-Sine, 200G, 2ms, ±XYZ, 1time	

Storage / Operating temperature

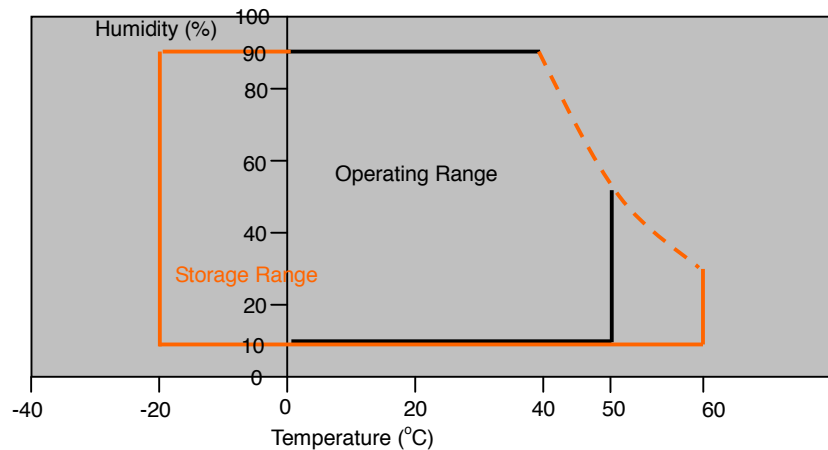

Note .Max wet bulb temp.=39°C

Document Title	HSD110PHW2-A Product Information	Page No.	20/24
Document No.		Revision	1.3

8.0 OUTLINE DIMENSION

Unit : mm

8.1 Front View Outline Dimension

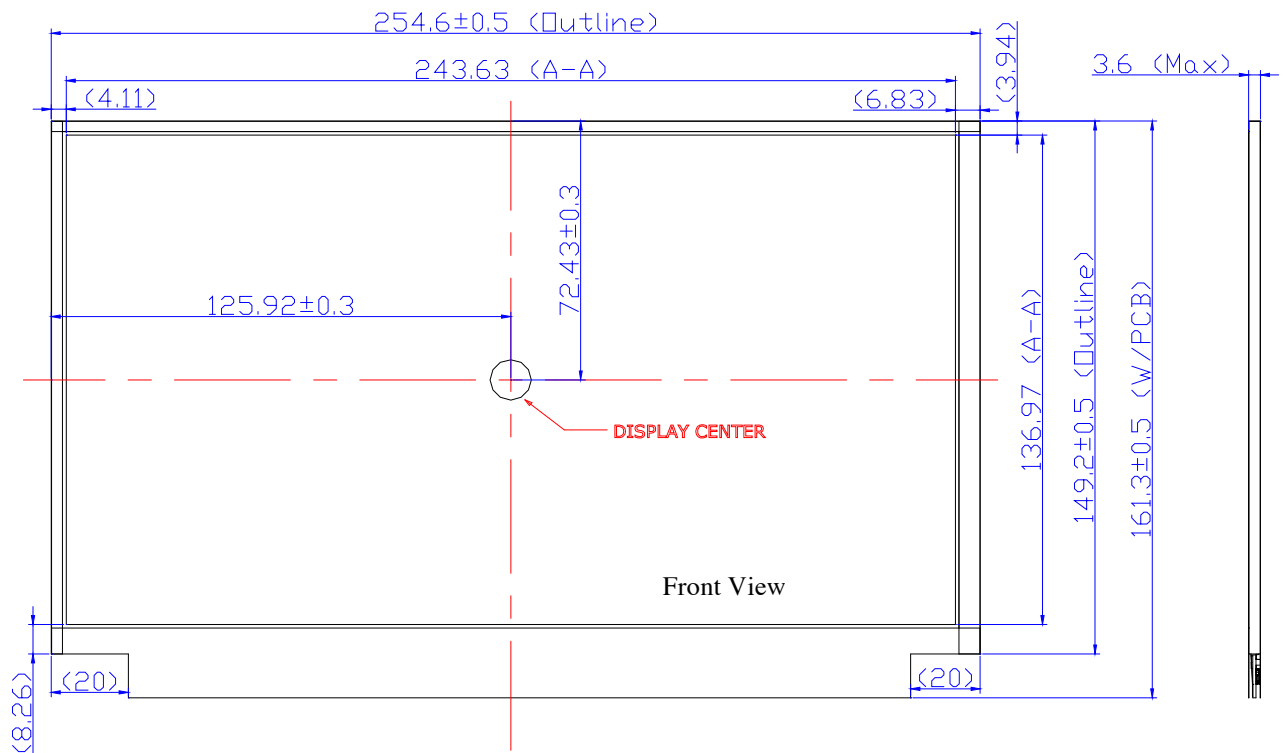

Document Title	HSD110PHW2-A Product Information	Page No.	21/24
Document No.		Revision	1.3

8.2 Back View Outline Dimension

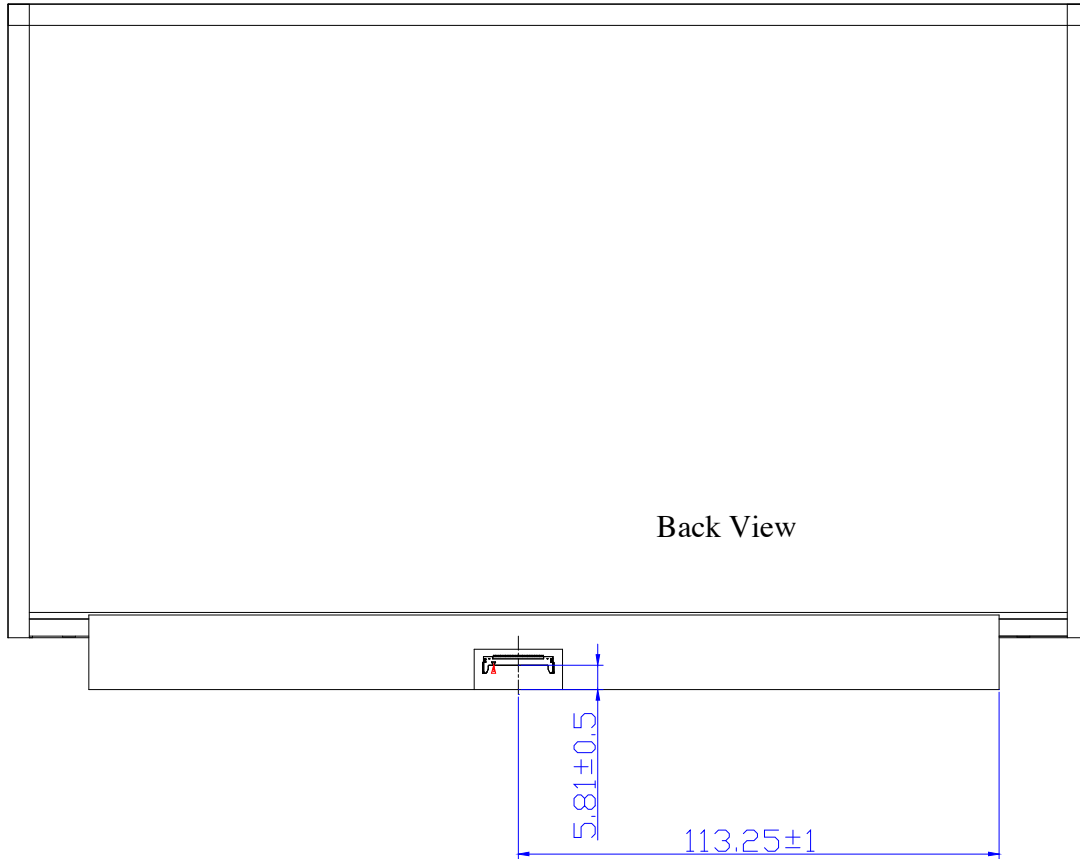

Document Title	HSD110PHW2-A Product Information	Page No.	22/24
Document No.		Revision	1.3

9.0 LOT MARK

9.1 Lot Mark

1	2	3	4	5	6	7	8	9	10	11	12	13	14	15
---	---	---	---	---	---	---	---	---	----	----	----	----	----	----

Code 1,2,3,4,5,6: HannStar internal flow control code.

Code 7: production location.

Code 8: production year.

Code 9: production month.

Code 10,11,12,13,14,15: serial number.

Note (1) Production Year

Year	2001	2002	2003	2004	2005	2006	2007	2008	2009	2010
Mark	1	2	3	4	5	6	7	8	9	0

Note (2) Production Month

Month	Jan.	Feb.	Mar.	Apr.	May.	Jun.	Jul.	Aug.	Sep.	Oct	Nov.	Dec.
Mark	1	2	3	4	5	6	7	8	9	A	B	C

9.2 Location of Lot Mark

(1) The label is attached to the backside of the LCD module.

(2) This is subject to change without prior notice.

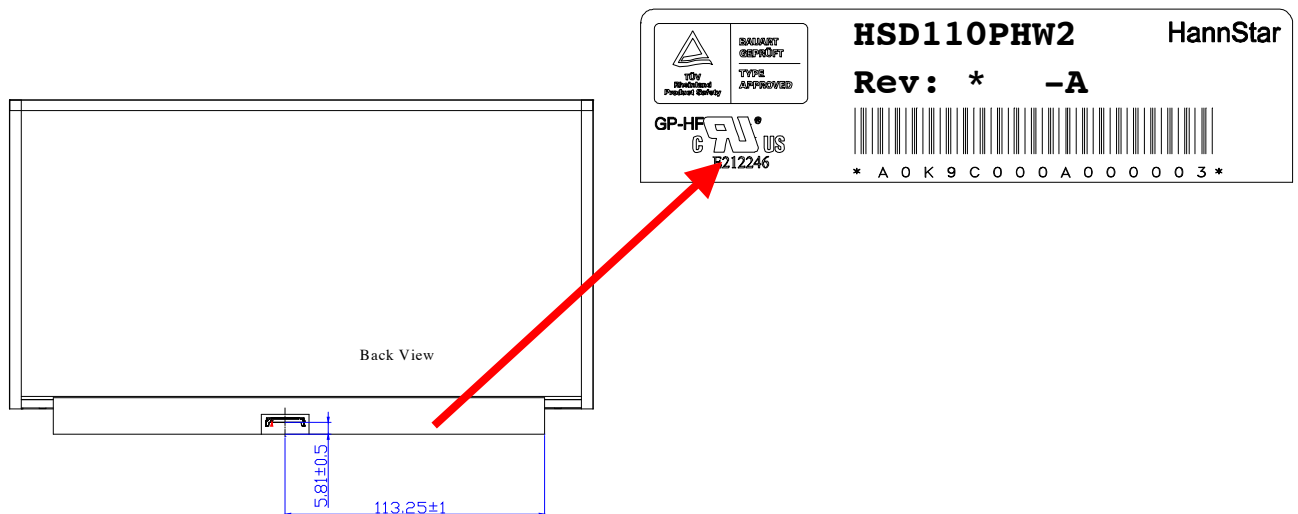



Document Title	HSD110PHW2-A Product Information	Page No.	23/24
Document No.		Revision	1.3

10.0 PACKAGE SPECIFICATION

10.1 Packing form

- (1) Package quantity in one carton: TBD.
- (2) Carton size: TBD.

10.2 Packing assembly drawings

11.0 GENERAL PRECAUTION

11.1 Use Restriction

This product is not authorized for use in life supporting systems, aircraft navigation control systems, military systems and any other application where performance failure could be life-threatening or otherwise catastrophic.

11.2 Disassembling or Modification

Do not disassemble or modify the module. It may damage sensitive parts inside LCD module, and may cause scratches or dust on the display. HannStar does not warrant the module, if customers disassemble or modify the module.

11.3 Breakage of LCD Panel

- 11.3.1. If LCD panel is broken and liquid crystal spills out, do not ingest or inhale liquid crystal, and do not contact liquid crystal with skin.
- 11.3.2. If liquid crystal contacts mouth or eyes, rinse out with water immediately.
- 11.3.3. If liquid crystal contacts skin or cloths, wash it off immediately with alcohol and rinse thoroughly with water.
- 11.3.4. Handle carefully with chips of glass that may cause injury, when the glass is broken.

11.4 Electric Shock

- 11.4.1. Disconnect power supply before handling LCD module.
- 11.4.2. Do not pull or fold the LED cable.
- 11.4.3. Do not touch the parts inside LCD modules and the fluorescent LED's connector or cables in order to prevent electric shock.

Document Title	HSD110PHW2-A Product Information	Page No.	24/24
Document No.		Revision	1.3

11.5 Absolute Maximum Ratings and Power Protection Circuit

11.5.1. Do not exceed the absolute maximum rating values, such as the supply voltage variation, input voltage variation, variation in parts' parameters, environmental temperature, etc., otherwise LCD module may be damaged.

11.5.2. Please do not leave LCD module in the environment of high humidity and high temperature for a long time.

11.5.3. It's recommended to employ protection circuit for power supply.

11.6 Operation

11.6.1 Do not touch, push or rub the polarizer with anything harder than HB pencil lead.

11.6.2 Use fingerstalls of soft gloves in order to keep clean display quality, when persons handle the LCD module for incoming inspection or assembly.

11.6.3 When the surface is dusty, please wipe gently with absorbent cotton or other soft material.

11.6.4 Wipe off saliva or water drops as soon as possible. If saliva or water drops contact with polarizer for a long time, they may causes deformation or color fading.

11.6.5 When cleaning the adhesives, please use absorbent cotton wetted with a little petroleum benzine or other adequate solvent.

11.7 Mechanism

Please mount LCD module by using mounting holes arranged in four corners tightly.

11.8 Static Electricity

11.8.1 Protection film must remove very slowly from the surface of LCD module to prevent from electrostatic occurrence.

11.8.2 Because LCD module use CMOS-IC on circuit board and TFT-LCD panel, it is very weak to electrostatic discharge. Please be careful with electrostatic discharge. Persons who handle the module should be grounded through adequate methods.

11.9 Strong Light Exposure

The module shall not be exposed under strong light such as direct sunlight. Otherwise, display characteristics may be changed.

11.10 Disposal

When disposing LCD module, obey the local environmental regulations.