



Document Title	HSD150MX17- A Formal Specification	Page No.	1 / 27
Document No.	DC140-0071	Revision	1.0

To :

Date : Dec.07.2005

Formal Specification

Model : **HSD150MX17**
- A**

- Note: 1.Please contact Hannstar Display Corp. before designing your product based on this module specification.
2.The information contained herein is presented merely to indicate the characteristics and performance of our products. No responsibility is assumed by Hannstar for any intellectual property claims or other problems that may result from application based on the module described herein.
3.The mark “ ** ” of Model means sub-model code.



Document Title	HSD150MX17- A Formal Specification	Page No.	2 / 27
Document No.	DC140-0071	Revision	1.0

Record of Revisions

Rev.	Updated No.	Date	Description of change
1.0		Dec.07.2005	Formal specification for HSD150MX17-A was first issued.



Document Title	HSD150MX17- A Formal Specification	Page No.	3 / 27
Document No.	DC140-0071	Revision	1.0

Contents

1.0	General Descriptions	p.4
2.0	Absolute Maximum Ratings	p.5
3.0	Optical Characteristics	p.7
4.0	Block Diagram	p.11
5.0	I/O Connection Pin Assignment	p.14
6.0	Electrical Characteristics	p.15
7.0	Outline Dimension	p.24
8.0	Lot Mark	p.26
9.0	Package Specification	p.27
10.0	General Precaution	p.27



Document Title	HSD150MX17- A Formal Specification	Page No.	4 / 27
Document No.	DC140-0071	Revision	1.0

1.0 GENERAL DESCRIPTIONS

1.1 Introduction

HannStar Display model **HSD150MX17-A** is a color active matrix thin film transistor (TFT) liquid crystal display (LCD) that uses amorphous silicon TFT as a switching device. This model is composed of a TFT LCD panel, the voltage reference, common voltage, DC-DC converter, column, and row driver circuit. This TFT LCD has a 15-inch diagonally measured active display area with XGA resolution (768 vertical by 1024 horizontal pixel array).

1.2 Features

- 15" XGA TFT LCD panel
- 2 CCFLs Backlight system
- Supported XGA (V:768 lines, H:1024 pixels) resolution
- Supported to 75Hz refresh rate
- With LCD Timing Controller

1.3 General information

Item	Specification	Unit
Outline dimension	326.5x253.5x10.6 (typ.)	mm
Display area	304.1(H) x 228.1(V) (15.0" diagonal)	mm
Number of Pixel	1024(H) x 768(V)	Pixels
Pixel pitch	0.297(H) x 0.297(V)	mm
Pixel arrangement	RGB Vertical stripe	
Display color	16 million(6 bit + FRC)	
Display mode	Normally white	
Surface treatment	Antiglare, Hard-Coating(3H)	
Weight	925(typ.)	g
Back-light	2-CCFLs, Top & bottom edge side	
Input signal	1ch-LVDS	
Power consumption (with B/L)	13 W(typ.), with back light	W
Optimum viewing direction	6 o'clock	

1.4 Applications

- Desktop monitors
- Display terminals for AV applications
- Monitors for industrial applications

Document Title	HSD150MX17- A Formal Specification	Page No.	5 / 27
Document No.	DC140-0071	Revision	1.0

1.5 Mechanical Information

Item		Min.	Typ.	Max.	Unit
Module Size	Horizontal(H)	326.0	326.5	327.0	mm
	Vertical(V)	253.0	253.5	254.0	mm
	Depth(D)	--	10.6	10.9	mm
Weight (without inverter)		--	925	955	g
Torque of customer screw hole				3.0	Kgf*Cm

2.0 ABSOLUTE MAXIMUM RATINGS

2.1 Absolute Rating of Environment

Item	Symbol	Min.	Max.	Unit	Note
Storage temperature	T _{STG}	-20	60	°C	
Operating temperature	T _{OPR}	0	50	°C	(1)
Vibration(non-operating)	V _{NOP}	--	1.5	G	(2)
Shock(non-operating)	S _{NOP}	--	70	G	(3)
Storage humidity	H _{STG}	10	90	%RH	(3)
Operating humidity	H _{OP}	10	80	%RH	(4)
Low pressure(operating)	P _{LOP}	697	--	HPa	(5)
Low pressure(non-operating)	P _{LNOP}	116	--	HPa	(6)

Note (1)Storage /Operating temperature

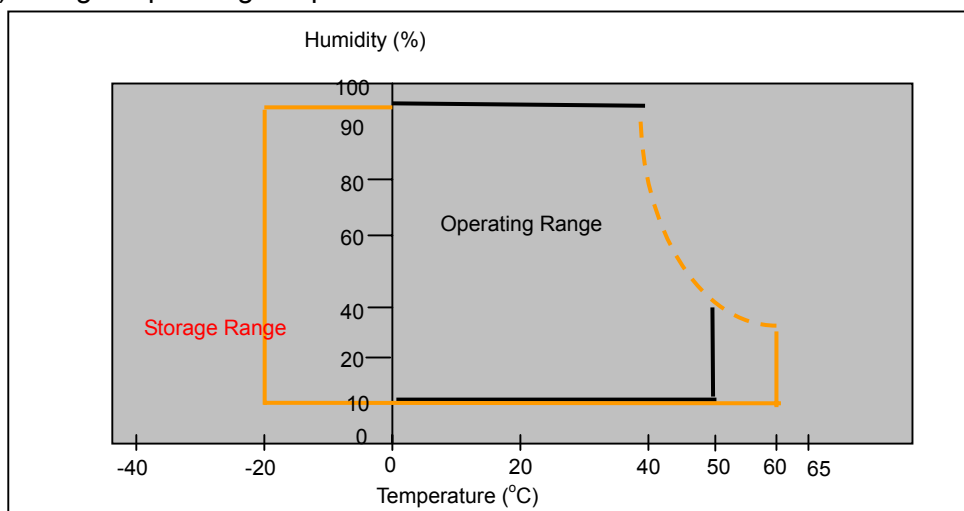

Document Title	HSD150MX17- A Formal Specification	Page No.	6 / 27
Document No.	DC140-0071	Revision	1.0

- (2) 5-500-5Hz sine wave, X,Y,Z each directions, 30 min/cycle.
- (3) 11ms, $\pm X$, $\pm Y$, $\pm Z$ direction, one time each. For this shock test,
It is necessary to fill the silicon rubber between the shock jig as buffer.
- (4) Max wet bulb temp. =39°C
- (5) 2 hrs. (10000 feet)
- (6) 24hrs. (50000 feet)

2.2 Electrical Absolute Rating:

2.2.1 TFT LCD Module:

Item	Symbol	Min.	Max.	Unit.	Note
Power supply Voltage	V_{DD}	+3.0	+3.6	V(DC)	(1)(2)
Logic input voltage	V_{SIG}	-0.3	$V_{DD} + 0.3$	V	(1)(2)

2.2.2 Back Light Unit:

Item	Symbol	Min.	Max.	Unit	Note
Lamp current	I_L	—	9.0	mA	(1)(2)
Lamp frequency	f_L	0	80	KHz	(1)(2)

Note: (1) Permanent damage may occur to the LCD module if beyond this specification.

Functional operation should be restricted to the conditions described under Normal Operating Conditions.

(2) Within $T_a = 25 \pm 2^\circ\text{C}$

Document Title	HSD150MX17- A Formal Specification	Page No.	7 / 27
Document No.	DC140-0071	Revision	1.0

3.0 OPTICAL CHARACTERISTICS

3.1 Optical specification

Item	Symbol	Condition	Min.	Typ.	Max.	Unit	Note	
Contrast	CR	$\Theta=0^\circ$ $\phi=0^\circ$ Normal viewing angle	500	600	--		(1)(2)	
Response time	Rising		TR +TF	--	12	18	msec	(1)(3)
	Falling							
White luminance (center of screen)	Y_L		200	250		cd/m ²	(1)(4)(5) (IL=8.0mA)	
Color chromaticity (CIE1931)	Red	Rx	0.604	0.634	0.664		(1)(4)	
		Ry	0.309	0.339	0.369			
	Green	Gx	0.255	0.285	0.315			
		Gy	0.557	0.587	0.617			
	Blue	Bx	0.114	0.144	0.174			
		By	0.045	0.075	0.105			
	White	Wx	0.280	0.310	0.340			
		Wy	0.300	0.330	0.360			
Viewing angle	Hor.	Θ_L	55	65	--			
		Θ_R	55	65	--			
	Ver.	Θ_H	35	45	--			
		Θ_L	45	55	--			
Viewing angle	Hor.	Θ_L	--	75	--			
		Θ_R	--	75	--			
	Ver.	Θ_H	--	55	--			
		Θ_L	--	65	--			
Brightness uniformity	B_{UNI}	$\Theta=0^\circ$ $\phi=0^\circ$	73	80	--	%	(6)	

3.2 Measuring Condition

- Measuring surrounding : dark room
- Lamp current I_{BL} : (8.0)±0.1mA, lamp freq. $F_L=55$ KHz, Inverter :HIU-766(11pf)
- $V_{DD1}=3.3V$, $f_V=60Hz$, $f_{DCLK}=32.5MHz$
- Surrounding temperature : 25±2°C
- 30min. Warm-up time.

Document Title	HSD150MX17- A Formal Specification	Page No.	8 / 27
Document No.	DC140-0071	Revision	1.0

3.3 Measuring Equipment

- LCD-7000 of Otsuka Electric Corp., which utilized MCPD-7000 for Chromaticity and BM-5A for other optical characteristics.
- Measuring spot size : 10~12mm

Note (1) Definition of Viewing Angle:

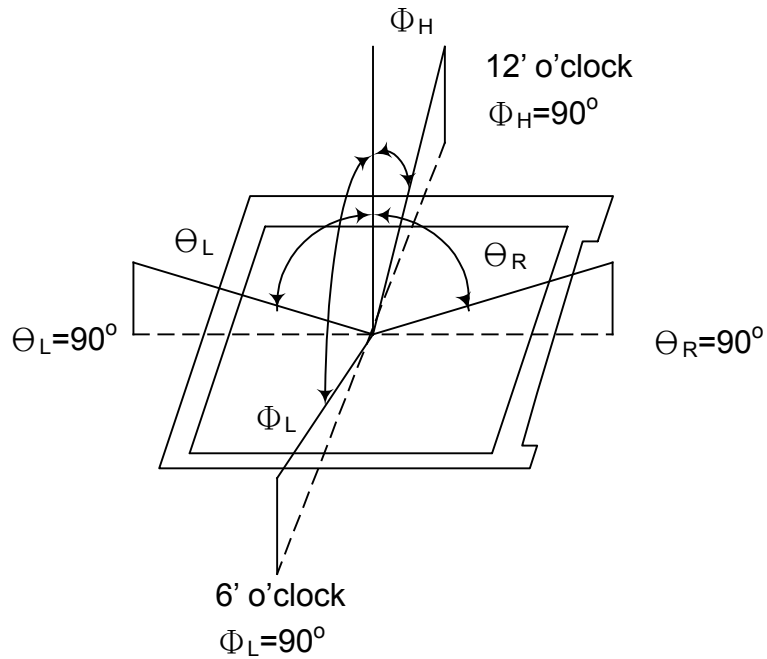

Note (2) Definition of Contrast Ratio(CR) :

measured at the center point of panel

$$CR = \frac{\text{Luminance with all pixels white (L255)}}{\text{Luminance with all pixels black (L0)}}$$

Document Title	HSD150MX17- A Formal Specification	Page No.	9 / 27
Document No.	DC140-0071	Revision	1.0

Note (3) Definition of Response Time: Sum of T_R and T_F

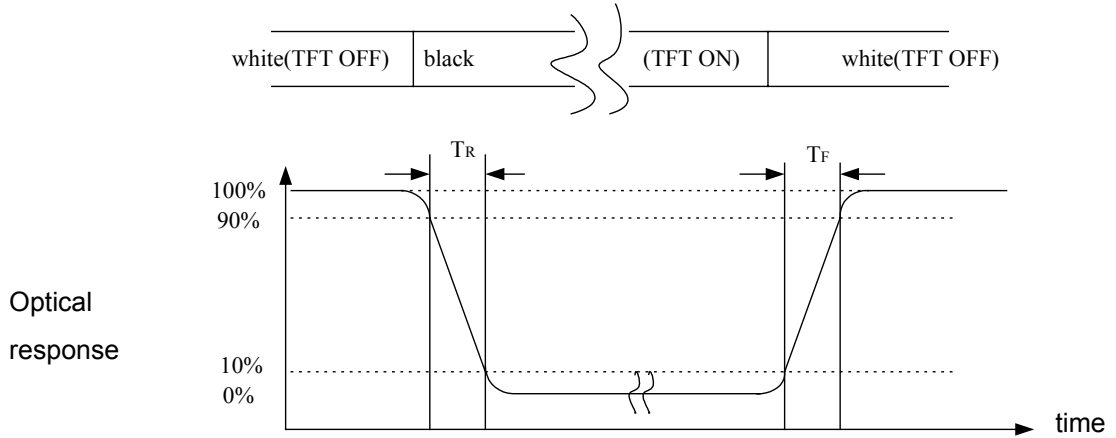

Note (4) Optical characteristic measurement setup

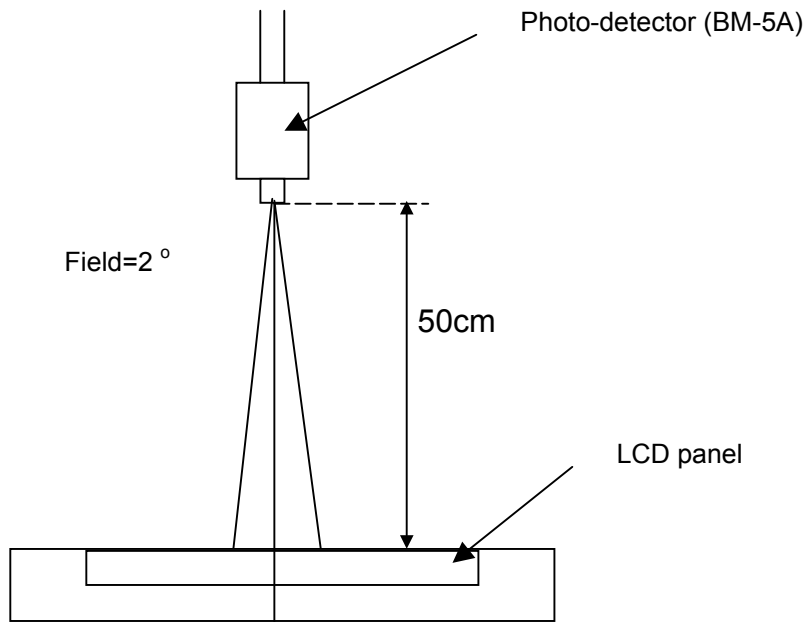

Document Title	HSD150MX17- A Formal Specification	Page No.	10 / 27
Document No.	DC140-0071	Revision	1.0

Note (5) Definition of Center Luminance of White (center)

Center Luminance= Y1

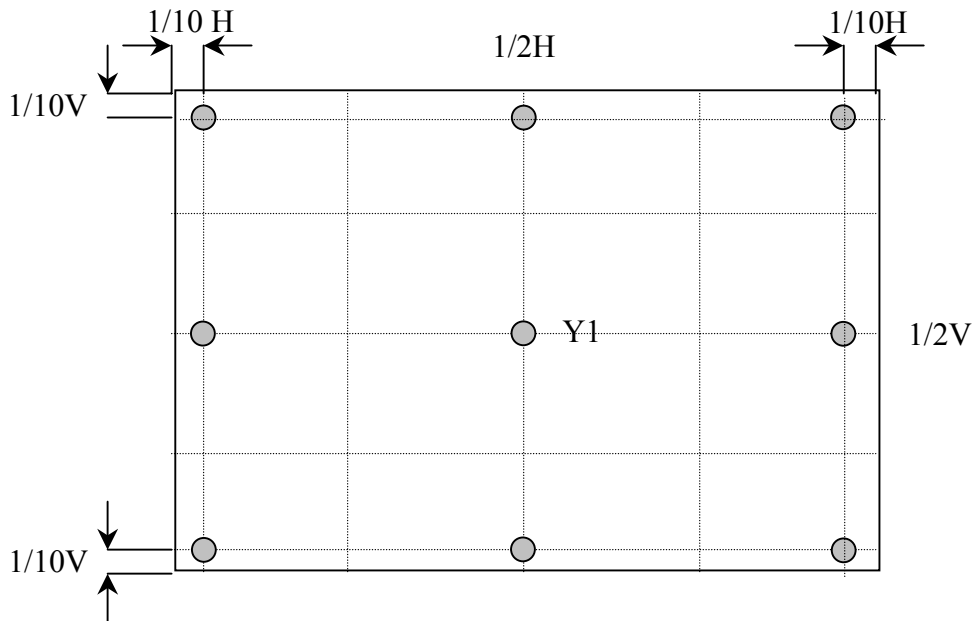

Note (6) Definition of brightness uniformity

$$\text{Luminance uniformity} = \frac{(\text{Min Luminance of 9points})}{(\text{Max Luminance of 9points})} \times 100\%$$

Document Title	HSD150MX17- A Formal Specification	Page No.	11 / 27
Document No.	DC140-0071	Revision	1.0

4.0 BLOCK DIAGRAM

4.1 LCD Module Block Diagram

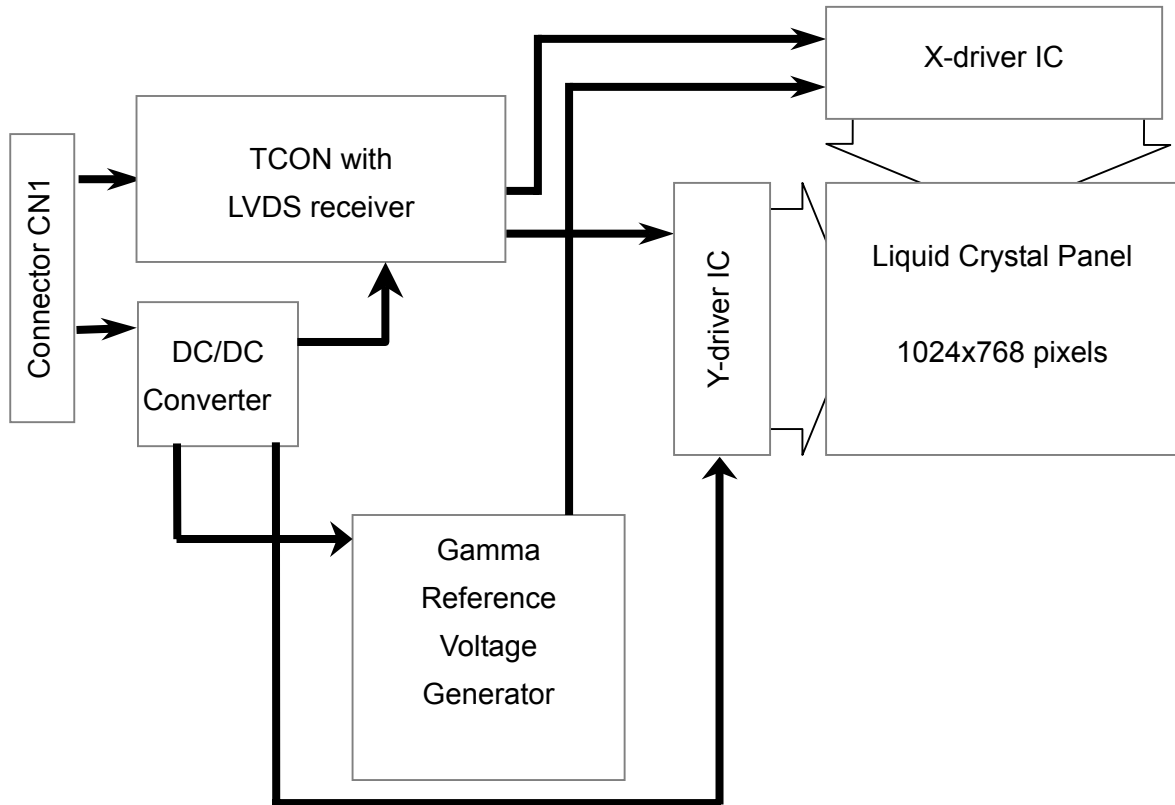

4.2 Back Light Unit

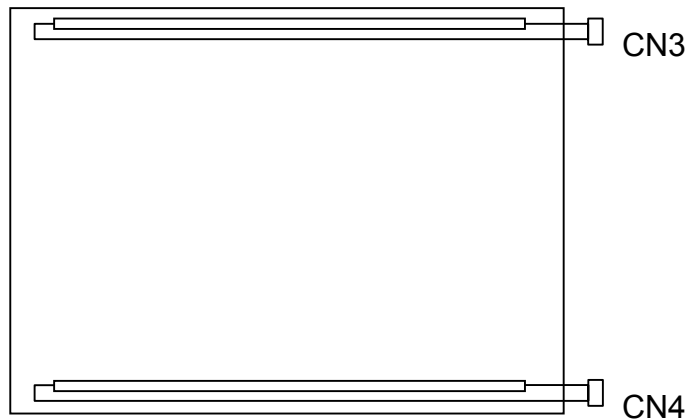

Document Title	HSD150MX17- A Formal Specification	Page No.	12 / 27
Document No.	DC140-0071	Revision	1.0

4.3 Pixel Format

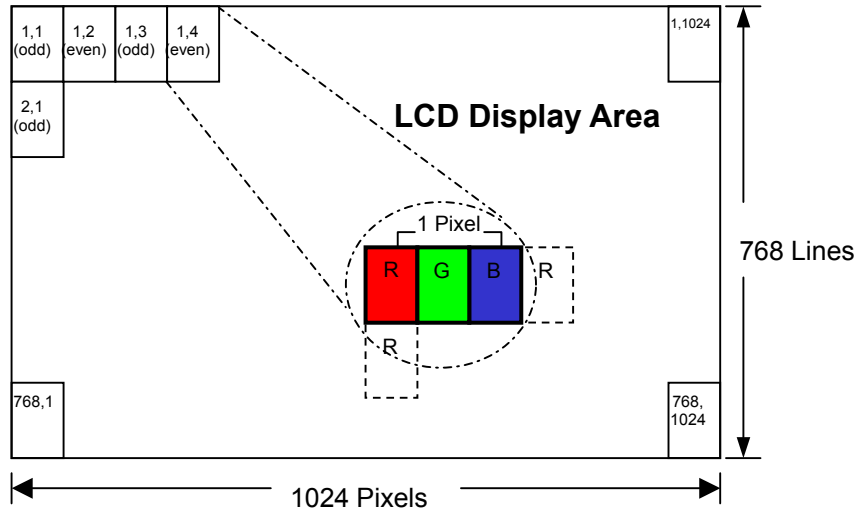



Document Title	HSD150MX17- A Formal Specification	Page No.	13 / 27
Document No.	DC140-0071	Revision	1.0

4.4 Relationship between Displayed Color and Input Data

Display	MSB				LSB				MSB				LSB				MSB				LSB				Gray scale Level		
	R7	R6	R5	R4	R3	R2	R1	R0	G7	G6	G5	G4	G3	G2	G1	G0	B7	B6	B5	B4	B3	B2	B1	B0			
Basic color	Black	L	L	L	L	L	L	L	L	L	L	L	L	L	L	L	L	L	L	L	L	L	L	L	L	-	
	Blue	L	L	L	L	L	L	L	L	L	L	L	L	L	L	L	L	H	H	H	H	H	H	H	H	-	
	Green	L	L	L	L	L	L	L	L	H	H	H	H	H	H	H	H	L	L	L	L	L	L	L	L	-	
	Light Blue	L	L	L	L	L	L	L	L	H	H	H	H	H	H	H	H	H	H	H	H	H	H	H	H	-	
	Red	H	H	H	H	H	H	H	H	L	L	L	L	L	L	L	L	L	L	L	L	L	L	L	L	-	
	Purple	H	H	H	H	H	H	H	H	L	L	L	L	L	L	L	L	H	H	H	H	H	H	H	H	-	
	Yellow	H	H	H	H	H	H	H	H	H	H	H	H	H	H	H	H	L	L	L	L	L	L	L	L	-	
	White	H	H	H	H	H	H	H	H	H	H	H	H	H	H	H	H	H	H	H	H	H	H	H	H	-	
Gray scale of Red	Black	L	L	L	L	L	L	L	L	L	L	L	L	L	L	L	L	L	L	L	L	L	L	L	L	L0	
	Dark	L	L	L	L	L	L	L	H	L	L	L	L	L	L	L	L	L	L	L	L	L	L	L	L	L1	
		L	L	L	L	L	L	H	L	L	L	L	L	L	L	L	L	L	L	L	L	L	L	L	L	L2	
		:	:	:	:	:	:	:	:	:	:	:	:	:	:	:	:	:	:	:	:	:	:	:	:	L3...L251	
	Light	H	H	H	H	H	H	L	L	L	L	L	L	L	L	L	L	L	L	L	L	L	L	L	L	L252	
		H	H	H	H	H	H	L	H	L	L	L	L	L	L	L	L	L	L	L	L	L	L	L	L	L253	
		H	H	H	H	H	H	H	L	L	L	L	L	L	L	L	L	L	L	L	L	L	L	L	L	L254	
Red	H	H	H	H	H	H	H	L	L	L	L	L	L	L	L	L	L	L	L	L	L	L	L	Red L255			
Gray scale of Green	Black	L	L	L	L	L	L	L	L	L	L	L	L	L	L	L	L	L	L	L	L	L	L	L	L	L0	
	Dark	L	L	L	L	L	L	L	L	L	L	L	L	L	L	H	L	L	L	L	L	L	L	L	L	L1	
		L	L	L	L	L	L	L	L	L	L	L	L	L	H	L	L	L	L	L	L	L	L	L	L	L2	
		:	:	:	:	:	:	:	:	:	:	:	:	:	:	:	:	:	:	:	:	:	:	:	:	L3...L251	
	Light	L	L	L	L	L	L	L	L	H	H	H	H	H	L	L	L	L	L	L	L	L	L	L	L252		
		L	L	L	L	L	L	L	L	H	H	H	H	H	L	H	L	L	L	L	L	L	L	L	L253		
		L	L	L	L	L	L	L	L	H	H	H	H	H	L	L	L	L	L	L	L	L	L	L	L254		
Green	L	L	L	L	L	L	L	H	H	H	H	H	H	H	L	L	L	L	L	L	L	L	Green L255				
Gray scale of Blue	Black	L	L	L	L	L	L	L	L	L	L	L	L	L	L	L	L	L	L	L	L	L	L	L	L	L0	
	Dark	L	L	L	L	L	L	L	L	L	L	L	L	L	L	L	L	L	L	L	L	L	L	H	L	L1	
		L	L	L	L	L	L	L	L	L	L	L	L	L	L	L	L	L	L	L	L	L	H	L	L	L2	
		:	:	:	:	:	:	:	:	:	:	:	:	:	:	:	:	:	:	:	:	:	:	:	:	L3...L251	
	Light	L	L	L	L	L	L	L	L	L	L	L	L	L	L	L	L	H	H	H	H	H	L	L	L	L252	
		L	L	L	L	L	L	L	L	L	L	L	L	L	L	L	L	H	H	H	H	H	L	H	L	L253	
		L	L	L	L	L	L	L	L	L	L	L	L	L	L	L	L	H	H	H	H	H	L	L	L	L254	
Blue	L	L	L	L	L	L	L	L	L	L	L	L	L	L	L	H	H	H	H	H	H	H	H	Blue L255			
Gray scale of White & Black	Black	L	L	L	L	L	L	L	L	L	L	L	L	L	L	L	L	L	L	L	L	L	L	L	L	L0	
	Dark	L	L	L	L	L	L	H	L	L	L	L	L	L	H	L	L	L	L	L	L	L	H	L	L1		
		L	L	L	L	L	L	H	L	L	L	L	L	L	H	L	L	L	L	L	L	L	H	L	L2		
		:	:	:	:	:	:	:	:	:	:	:	:	:	:	:	:	:	:	:	:	:	:	:	:	L3...L251	
	Light	H	H	H	H	H	L	L	H	H	H	H	L	L	H	H	H	H	L	L	H	H	H	H	L	L	L252
		H	H	H	H	H	L	H	H	H	H	H	L	H	H	H	H	H	L	H	H	H	H	H	L	H	L253
		H	H	H	H	H	H	L	H	H	H	H	H	L	H	H	H	H	L	H	H	H	H	L	L	L254	
White	H	H	H	H	H	H	H	H	H	H	H	H	H	H	H	H	H	H	H	H	H	H	H	H	White L255		

Document Title	HSD150MX17- A Formal Specification	Page No.	14 / 27
Document No.	DC140-0071	Revision	1.0

5.0 I/O CONNECTION PIN ASSIGNMENT

5.1 Interface Connector (20-pins x 1) (Hirose: DF14H-20P-1.25H or equivalent)

I/F Connector (CH11)		
Pin No.	Symbol	Description
1	VDD	Power Supply, 3.3v (typical)
2	VDD	Power Supply, 3.3v (typical)
3	VSS	Ground
4	VSS	Ground
5	Rin0-	-LVDS differential data input(R0-R5, G0)
6	Rin0+	+LVDS differential data input(R0-R5, G0)
7	VSS	Ground
8	Rin1-	-LVDS differential data input(G1-G5, B0-B1)
9	Rin1+	+LVDS differential data input(G1-G5, B0-B1)
10	VSS	Ground
11	Rin2-	-LVDS differential data input(B2-B5, HS, VS, DE)
12	Rin2+	+LVDS differential data input(B2-B5, HS, VS, DE)
13	VSS	Ground
14	ClkIN-	-LVDS differential clock input
15	ClkIN+	+LVDS differential clock input
16	VSS	Ground
17	Rin3-	-LVDS differential data input(R6-R7, G6-G7, B6-B7)
18	Rin3+	+LVDS differential data input(R6-R7, G6-G7, B6-B7)
19	VSS	Ground
20	VSS	Ground

4.5 Back Light Unit (CCFL) Connectors:

CN3, 4: CCFL Power Source (BHR-03VS-1/Japan Solderless Terminal MFG Co., LTD or equivalent)

Mating connector: SM02 (8.0)B-BHS-1/ Japan Solderless Terminal MFG Co., LTD or equivalent

Terminal No.	Symbol	Function
1	VL	CCFL power supply (high voltage)
2	NC	No connection
3	GL	CCFL power supply (low voltage)

Note: Please connects NC pin to nothing. Don't connect it to ground nor to other signal Input. (NC pin should be open.)

Document Title	HSD150MX17- A Formal Specification	Page No.	15 / 27
Document No.	DC140-0071	Revision	1.0

6.0 ELECTRICAL CHARACTERISTICS

6.1 TFT LCD Module:

Item	Symbol	Min.	Typ.	Max.	Unit	Note	
Voltage of power supply	V_{DD}	3.0	3.3	3.6	V		
Current of power supply	V-Color	I_{DD1}	260	360	460	mA	(1)(3)
	Mosaic	I_{DD2}	290	390	490	mA	(1)(3)
Vsync frequency	f_V	56	60	76	Hz	(2)(3)	
Hsync frequency	f_H	-	48.36	75	KHz		
Frequency	f_{DCLK}	-	65.00	80	MHz		
Input rush current	I_{RUSH}	---	---	1.5	A	(3)(4)	

Note (1)

1). V-Color :

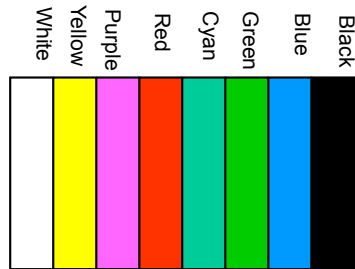

2). Mosaic : Dot checker image

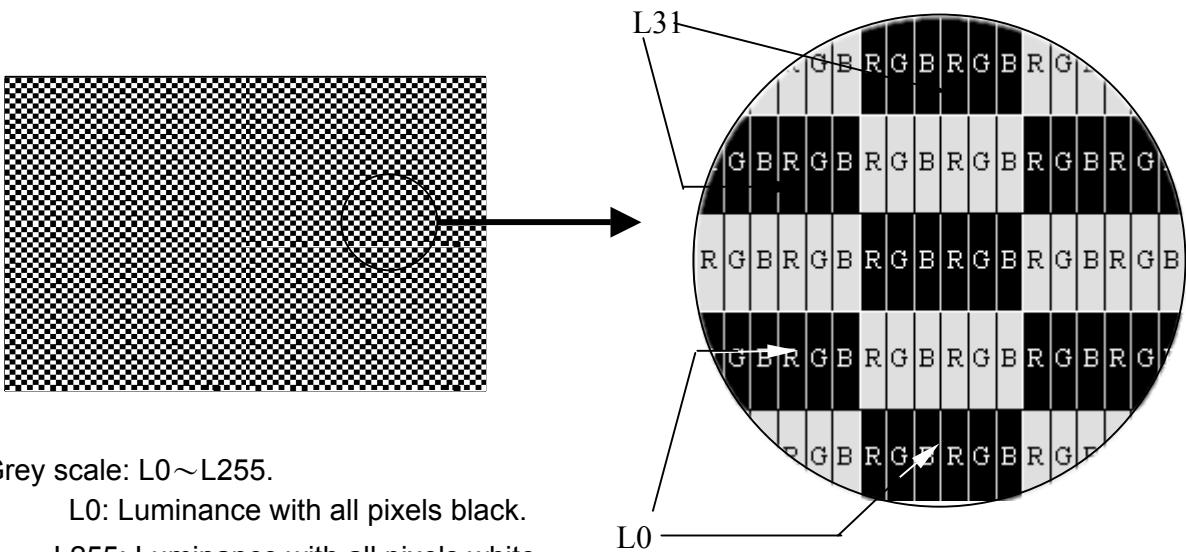

Document Title	HSD150MX17- A Formal Specification	Page No.	16 / 27
Document No.	DC140-0071	Revision	1.0

Note (2) When f_v is too low, a flicker may be occurred on the display.

Note (3) Input Rush Current condition

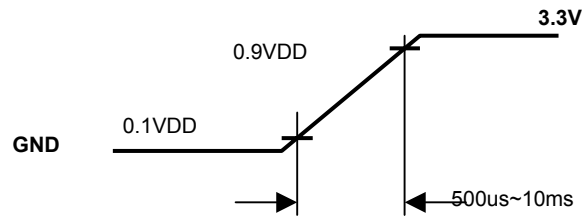

Document Title	HSD150MX17- A Formal Specification	Page No.	17 / 27
Document No.	DC140-0071	Revision	1.0

6.2 Back-Light Unit

The back-light system is an edge-lighting type with 2 CCFL(Cold Cathode Fluorescent Lamp). The characteristics of the lamp is shown in the following tables.

Item	Symbol	Min.	Typ.	Max.	Unit	Note
Lamp current	IL	3.0	8.0	9.0	mA(rms)	(1)
Lamp voltage	VL	576	640	700	V(rms)	$I_L=8.0mA$
Frequency	fL	50	55	80	kHz	(2)
Operating lamp life time	Hr	30,000	--	--	Hour	(3)
Startup voltage	Vs	1380	--	--	V(rms)	at 25°C
		1590				at 0°C

Note (1)

Lamp current is measured with current meter for high frequency as shown below. Specified values are for a single lamp.

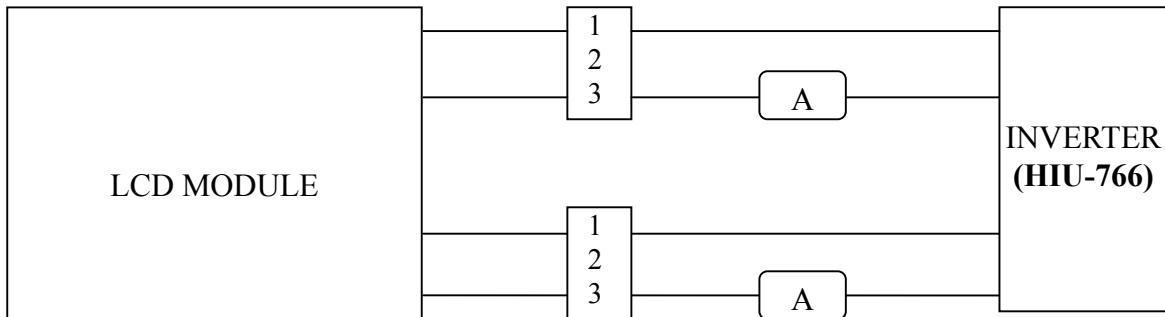

Note (2)

Lamp frequency may produce interference with horizontal synchronous frequency and this may cause ripple noise on the display. Therefore lamp frequency shall be kept away from the horizontal synchronous frequency and its harmonics as far as possible in order to avoid interference.

Note (3)

Lamp life time (Hr) can be defined as the time in which it continues to operate under the condition : $T_a=25\pm3^\circ C$, Typical I_L value indicated in the above table and $f_L=55kHz$ until the brightness becomes less than 50%

Note (4)

CCFL inverter should be able to provide a voltage over specified value (V_s) in the above table. Lamp units need at least V_s value shown above to ignition.

Note (5)

The voltage over specified value (V_s) should be applied to the lamp more than 1 second after startup. Otherwise, the lamp may not be turned on. The used lamp current is the lamp typical current.

Document Title	HSD150MX17- A Formal Specification	Page No.	18 / 27
Document No.	DC140-0071	Revision	1.0

Note (6)

The output voltage waveform and current waveform of the inverter must be symmetrical (Unsymmetrical ratio is less than 10%). Please do not use the inverter which has unsymmetrical voltage and current waveform, and spike waveform. The inverter design which can provide the best optical performance, power efficiency, and lamp life should under the following conditions.

- The asymmetry rate of the inverter waveform should be less than 10%.
- The distortion rate of the waveform should be within $\sqrt{2} \pm 10\%$.
- The inverter output waveform should be better similar to the ideal sine wave.

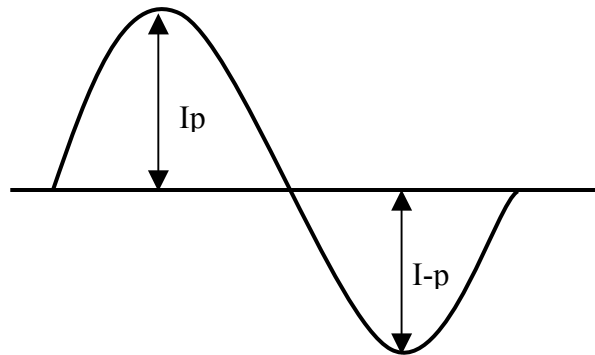

$$\text{Asymmetry rate} = |I_p - I_p| / I_{rms} \times 100\%$$

$$\text{Distortion rate} = I_p \text{ (or } I_p) / I_{rms}$$

Document Title	HSD150MX17- A Formal Specification	Page No.	19 / 27
Document No.	DC140-0071	Revision	1.0

6.3 AC Electrical Characteristics:

6.3.1 Timing Parameters (DE mode)

Item	Symbol	Min.	Typ.	Max.	Unit
Frame Rate	--	56	60	76	Hz
Frame Period	t1	1028	1066	1150	line
Vertical Display Time	t2	1024	1024	1024	line
Vertical Blanking Time	t3	4	42	126	line
1 Line Scanning Time	t4	780	844	875	clock
Horizontal Display Time	t5	640	640	640	clock
Horizontal Blanking Time	t6	140	204	235	clock
Clock Rate	t7	50	54	67.5	MHz

6.3.2 Timing Diagram of Interface Signal (DE mode)

(1)Vertical

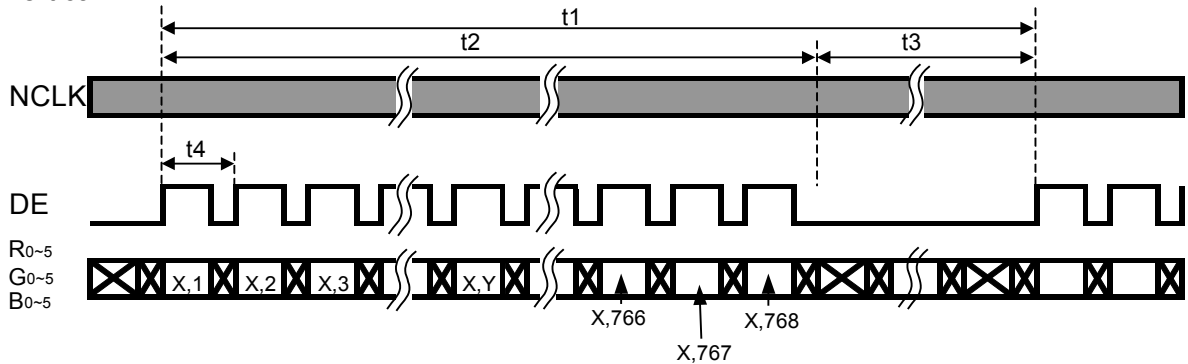

(2)Horizontal

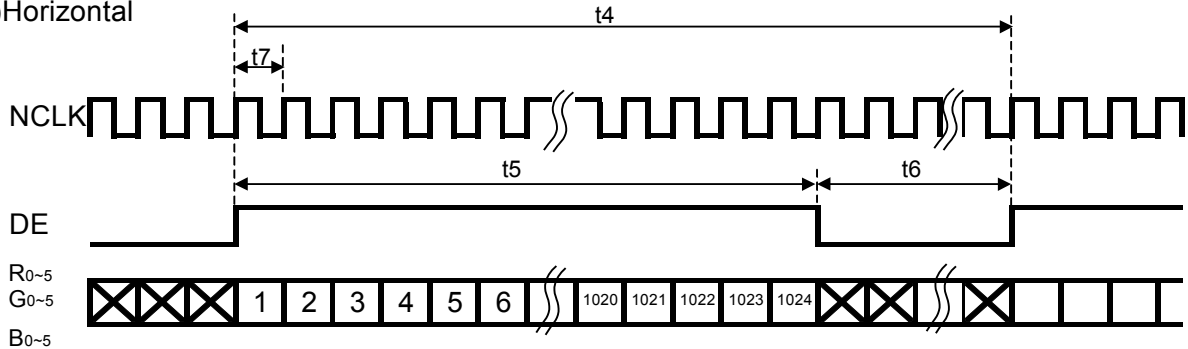

Document Title	HSD150MX17- A Formal Specification	Page No.	20 / 27
Document No.	DC140-0071	Revision	1.0

6.4 Power On / Off Sequence :

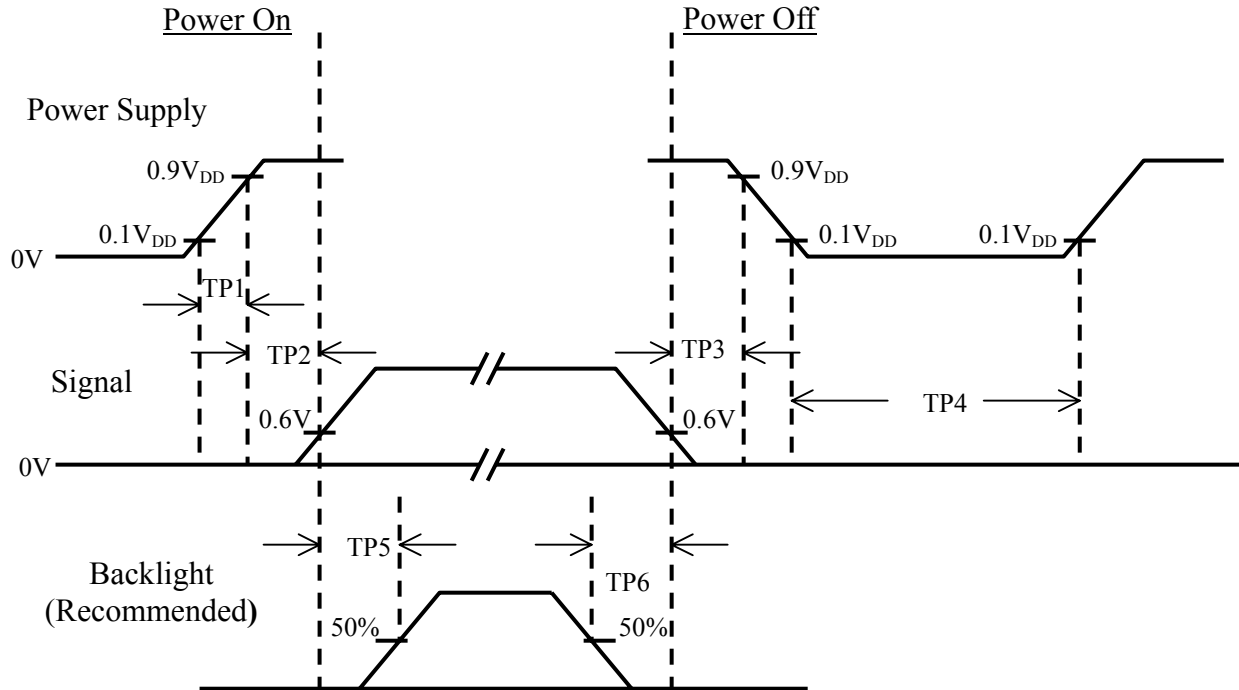

Item	Min.	Typ.	Max.	Unit	Remark
TP1	0.5	—	10	msec	
TP2	0	—	50	msec	
TP3	0	—	50	msec	
TP4	1	—	—	sec	
TP5	200	—	—	msec	
TP6	200	—	—	msec	

Note : (1) The supply voltage of the external system for the module input should be the same as the definition of V_{DD} .

(2) Apply the lamp volatge within the LCD operation range. When the back-light turns on before the LCD operation or the LCD truns off before the back-light turns off, the display may momentarily become white.

(3) In case of $V_{DD} = \text{off level}$, please keep the level of input signal on the low or keep a high impedance.

(4) T4 should be measured after the module has been fully discharged between power off and on period.

(5)Interface signal shall not be kept at high impedance when the power is on.

Document Title	HSD150MX17- A Formal Specification	Page No.	21 / 27
Document No.	DC140-0071	Revision	1.0

7.0 OUTLINE DIMENSION

7.1 Front View:

Date: 2003.09.08

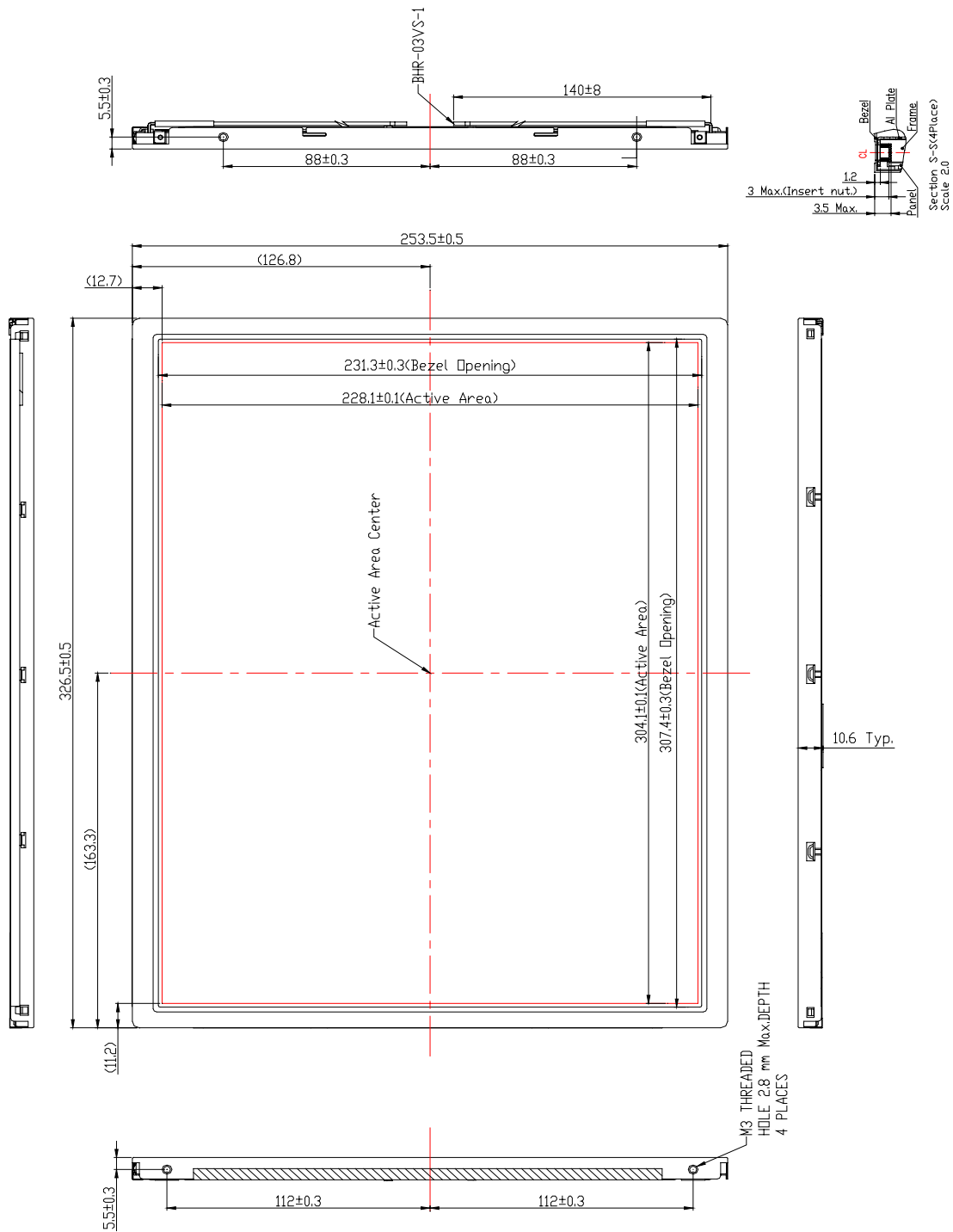



Document Title	HSD150MX17- A Formal Specification	Page No.	22 / 27
Document No.	DC140-0071	Revision	1.0

7.2 Back View:

Date: 2003.09.08

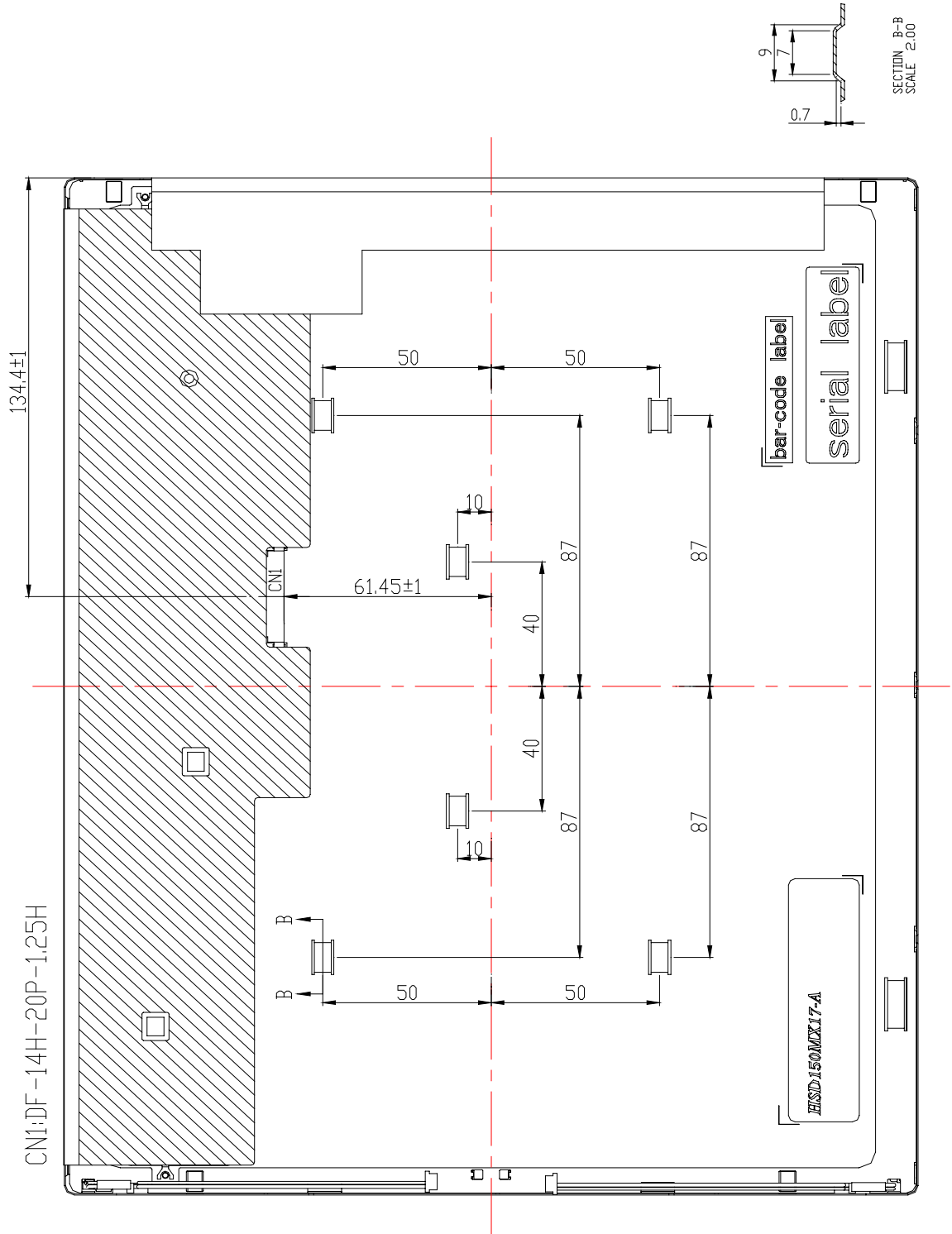

Document Title	HSD150MX17- A Formal Specification	Page No.	23 / 27
Document No.	DC140-0071	Revision	1.0

8.0 LOT MARK

8.1 Lot Mark

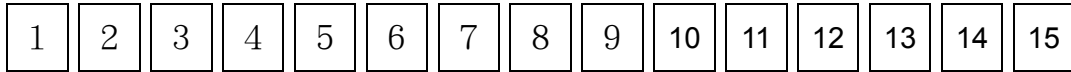

code 1,2,3,4,5,6: HannStar internal flow control code.

code 7: production location.

code 8: production year.

code 9: production month.

code 10,11,12,13,14,15: serial number.

Note (1) Production Year

Year	1999	2000	2001	2002	2003	2004	2005	2006	2007	2008
Mark	9	0	1	2	3	4	5	6	7	8

Note (2) Production Month

Month	Jan.	Feb.	Mar.	Apr.	May.	Jun.	Jul.	Aug.	Sep.	Oct.	Nov.	Dec.
Mark	1	2	3	4	5	6	7	8	9	A	B	C

8.2 Location of Lot Mark

- (1) The label is attached to the backside of the LCD module.
- (2) This is subject to change without prior notice.

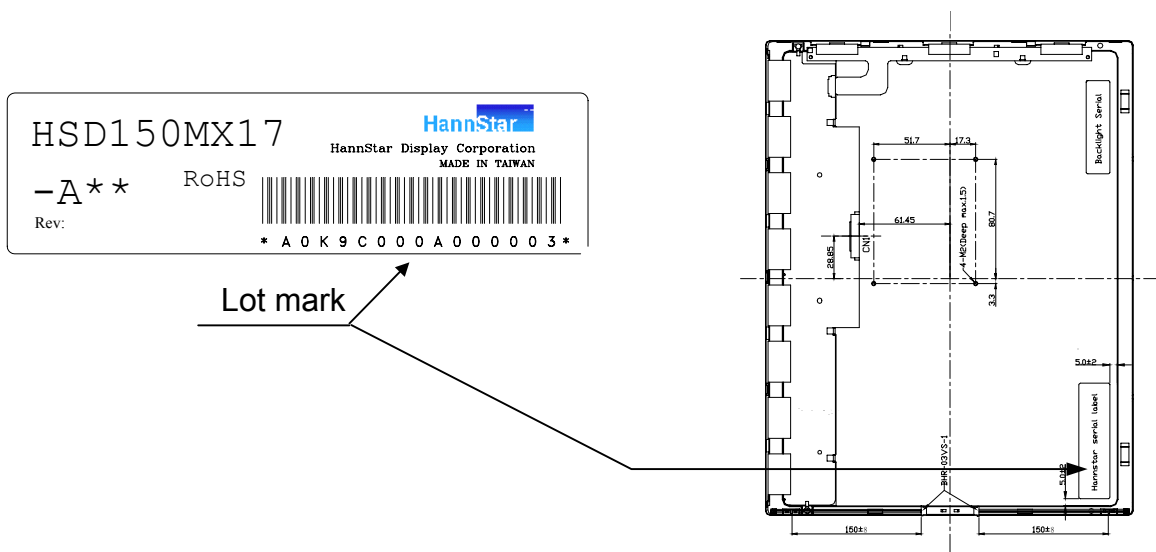



Document Title	HSD150MX17- A Formal Specification	Page No.	24 / 27
Document No.	DC140-0071	Revision	1.0

9.0 PACKAGE SPECIFICATION

Please refer to Hannstar document(DC111-0003 15" LCD Module Package Specification (Monitor Type 1)

10.0 GENERAL PRECAUTION

10.1 Use Restriction

This product is not authorized for use in life supporting systems, aircraft navigation control systems, military systems and any other application where performance failure could be life-threatening or otherwise catastrophic.

10.2 Disassembling or Modification

Do not disassemble or modify the module. It may damage sensitive parts inside LCD module, and may cause scratches or dust on the display. HannStar does not warrant the module, if customers disassemble or modify the module.

10.3 Breakage of LCD Panel

10.3.1 If LCD panel is broken and liquid crystal spills out, do not ingest or inhale liquid crystal, and do not contact liquid crystal with skin.

10.3.2 If liquid crystal contacts mouth or eyes, rinse out with water immediately.

10.3.3 If liquid crystal contacts skin or cloths, wash it off immediately with alcohol and rinse thoroughly with water.

10.3.4 Handle carefully with chips of glass that may cause injury, when the glass is broken.

10.4 Electric Shock

10.4.1 Disconnect power supply before handling LCD module.

10.4.2 Do not pull or fold the CCFL cable.

10.4.3 Do not touch the parts inside LCD modules and the fluorescent lamp's connector or cables in order to prevent electric shock.

10.5 Absolute Maximum Ratings and Power Protection Circuit

10.5.1 Do not exceed the absolute maximum rating values, such as the supply voltage variation, input voltage variation, variation in parts' parameters, environmental temperature, etc., otherwise LCD module may be damaged.

10.5.2 Please do not leave LCD module in the environment of high humidity and high temperature for a long time.

10.5.3 It's recommended employing protection circuit for power supply.



Document Title	HSD150MX17- A Formal Specification	Page No.	25 / 27
Document No.	DC140-0071	Revision	1.0

10.6 Operation

10.6.1 Do not touch, push or rub the polarizer with anything harder than HB pencil lead. Use fingerstalls of soft gloves in order to keep clean display quality, when persons handle the LCD module for incoming inspection or assembly.

10.6.2 When the surface is dusty, please wipe gently with absorbent cotton or other soft material.

10.6.3 Wipe off saliva or water drops as soon as possible. If saliva or water drops contact with polarizer for a long time, they may causes deformation or color fading.

10.6.4 When cleaning the adhesives, please use absorbent cotton wetted with a little petroleum benzene or other adequate solvent.

10.7 Mechanism

Please mount LCD module by using mounting holes arranged in four corners tightly.

10.8 Static Electricity

10.8.1 Protection film must remove very slowly from the surface of LCD module to prevent from electrostatic occurrence.

10.8.2 Because LCD module uses CMOS-IC on circuit board and TFT-LCD panel, it is very weak to electrostatic discharge. Please be careful with electrostatic discharge.

10.8.3 Persons who handle the module should be grounded through adequate methods.

10.9 Strong Light Exposure

The module shall not be exposed under strong light such as direct sunlight. Otherwise, display characteristics may be changed.

10.10 Disposal

When disposing LCD module, obey the local environmental regulations.

Document Title	HSD150MX17- A Formal Specification	Page No.	26 / 27
Document No.	DC140-0071	Revision	1.0

HSD150MX17-A01~HSD150MX17-A05 be RoHS compliance.

1.2 Features

- 15" XGA TFT LCD panel
- 2 CCFLs Backlight system
- Supported XGA (V: 768 lines, H:1024 pixels) resolution
- Supported to 75Hz refresh rate
- With LCD Timing Controller
- RoHS Compliance

8.3 Location of Lot Mark

- (1) The label is attached to the backside of the LCD module.
- (2) This is subject to change without prior notice.

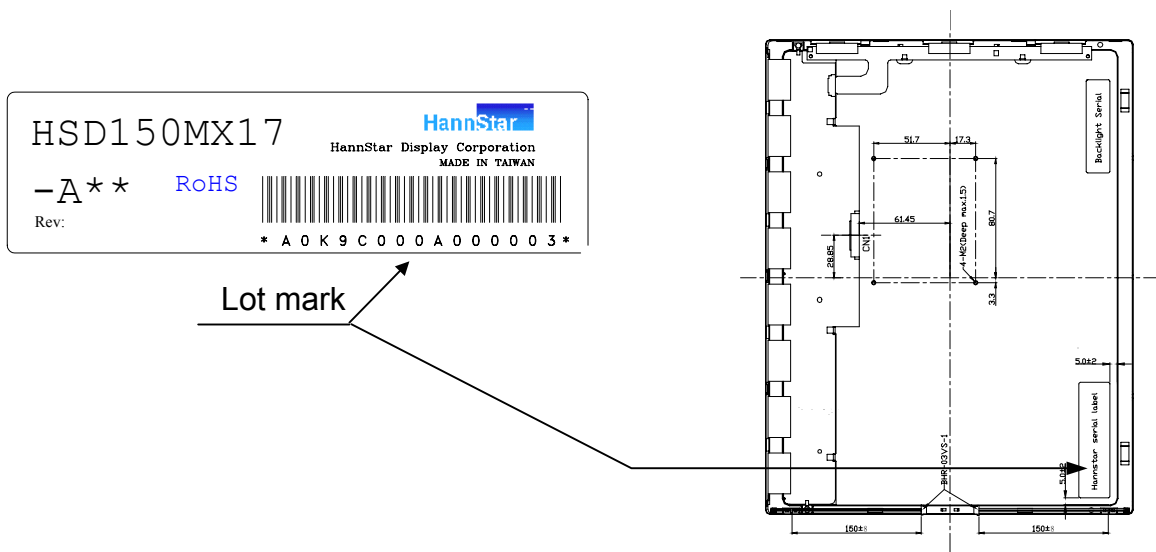

Document Title	HSD150MX17- A Formal Specification	Page No.	27 / 27
Document No.	DC140-0071	Revision	1.0

HSD150MX17-A05

The optical specification was new, because the Response time and viewing angle issue

3.1 Optical specification

Item	Symbol	Condition	Min.	Typ.	Max.	Unit	Note	
Contrast	CR	$\Theta=0^{\circ}$ $\phi=0^{\circ}$ Normal viewing angle	500	600	--		(1)(2)	
Response time	Rising		TR	--	4	7	msec	(1)(3)
	Falling		TF		8	11		
White luminance (center of screen)	Y_L			200	250		cd/m ²	(1)(4)(5) (IL=8.0mA)
Color chromaticity (CIE1931)	Red	Rx	0.604	0.634	0.664		(1)(4)	
		Ry	0.309	0.339	0.369			
	Green	Gx	0.255	0.285	0.315			
		Gy	0.557	0.587	0.617			
	Blue	Bx	0.114	0.144	0.174			
		By	0.045	0.075	0.105			
	White	Wx	0.280	0.310	0.340			
		Wy	0.300	0.330	0.360			
Viewing angle	Hor.	Θ_L	60	70	--			
		Θ_R	60	70	--			
	Ver.	Θ_H	55	65	--			
		Θ_L	55	65	--			
Brightness uniformity	B_{UNI}	$\Theta=0^{\circ}$ $\phi=0^{\circ}$	73	80	--	%	(6)	