

Date: May. 29, 2009

TECHNICAL DATA

TMD54X110CBB

CONTENTS

No.	Item	Sheet No.	Page
—	COVER	DPBCL0002037-1	1-1/1
—	RECORD OF REVISION	DPBCL0002037-1	2-1/1
—	APPLICATION	DPBCL0002037-1	3-1/1
—	DESCRIPTION	DPBCL0002037-1	4-1/1
1	ABSOLUTE MAXIMUM RATINGS	DPBCL0002037-1	5-1/1
2	OPTICAL CHARACTERISTICS	DPBCL0002037-1	6-1/2 - 6-2/2
3	ELECTRICAL CHARACTERISTICS	DPBCL0002037-1	7-1/1
4	BLOCK DIAGRAM	DPBCL0002037-1	8-1/1
5	INTERFACE PIN ASSIGNMENT	DPBCL0002037-1	9-1/6 - 9-6/6
6	TIMING DIAGRAMS OF INTERFACE TIMING	DPBCL0002037-1	10-1/3 - 10-3/3
7	DIMENSIONAL OUTLINE	DPBCL0002037-1	11-1/2 - 11-2/2
6	DESIGNATION OF LOT MARK	DPBCL0002037-1	12-1/1
7	PRECAUTION	DPBCL0002037-1	13-1/3 - 13-3/3

The information described in this technical specification is tentative and it is possible to be changed without prior notice.

RECORD OF REVISION

Date	The upper section : Before revision The lower section : After revision		Summary
	Sheet No.	Page	

APPLICATION

In the case of applying this product for such as control and safety device of transportation facilities (airplane, train, automobile, ship, etc), equipments aiming for rescue and security, and the other safety related devices which should secure higher reliability and safety, please make it sure that proper countermeasure such as fail-safe functions and enough system design for the protection are mandatory.

Please do not apply this product for equipments or devices which need exceedingly high reliability, such as aerospace applications, telecommunication facilities (trunk lines), nuclear related equipments or plants, and critical life support devices or applications. Usage style of this product is limited to Landscape mode. Optical characteristics mentioned in this spec. sheet is applied for only initial stage after delivery, and the characteristics will be changed by long time usage. Reliability of this product is secured as normal office use.

Hitachi Displays, Ltd.	Date	May. 29, 2009	Sh. No.	DPBCL0002037-1	Page	3-1/1
------------------------	------	---------------	------------	----------------	------	-------

DESCRIPTION

The following specifications are applied to the following Super-TFT module.

Note : Inverter for back light unit is not built in this module.

Product Name : TMD54X110CBB

GENERAL SPECIFICATIONS

Effective Display Area	: (H) 432.0 × (V) 324.0 (mm)
Number of Pixels	: (H) 1,600 × (V) 1,200 (pixels)
Pixel Pitch	: (H) 0.270 × (V) 0.270 (mm)
Color Pixel Arrangement	: R+G+B Vertical Stripe
Display Mode	: Transmissive Mode Normally Black Mode AS-IPS
Top Polarizer Type	: Anti-glare
Number of Colors	: 16,777,216 colors
Viewing Angle Range	: Super Wide Version
Input Signal	: 2-channel LVDS (LVDS: Low Voltage Differential Signaling)
Back Light	: 6 pcs. of CCFL
External Dimensions	: (H) 460.6 × (V) 362 × (t) 25 (mm)
Weight	: Max. 4,000 (g) (Typ.3,450 (g))
RoHS	: Compliance
Application	: Medical; Professional Desk-top Monitor

1. ABSOLUTE MAXIMUM RATINGS

1.1 ELECTRICAL ABSOLUTE MAXIMUM RATINGS

Item	Operating		Storage		Unit	Note
	Min.	Max.	Min.	Max.		
Temperature	0	50	-20	65	°C	1)
Humidity	2)		2)		%RH	1)
Vibration	—	4.9 (0.5G)	—	14.7 (1.5G)	m/s ²	3)
Shock	—	29.4 (3G)	—	294 (30G)		4)
Corrosive Gas	Not Acceptable		Not Acceptable		—	—
Illumination at LCD Surface	—	50,000	—	50,000	lx	—

Notes 1) Temperature and Humidity should be applied to the center glass surface of a Super-TFT module, not to the system installed with a module.

The temperature at the center of rear surface should be less than 60°C on the condition of operating. Function of module is guaranteed in above operating temperature range, but optical characteristics is specified for only 25°C operating condition.

The brightness of a CCFL tends to drop at low temperature. Besides, the life-time becomes shorter at low temperature.

2) $T_a \leq 40^\circ\text{C}$ Relative humidity should be less than 85%RH max. Dew is prohibited.

$T_a > 40^\circ\text{C}$ Relative humidity should be lower than the moisture of the 85%RH at 40°C.

3) Frequency of the vibration is between 15Hz and 100Hz. (Remove the resonance point)

4) Pulse width of the shock is 10 ms.

1.2 ELECTRICAL ABSOLUTE MAXIMUM RATINGS

(1) Super-TFT Module

$V_{SS}=0V$

Item	Symbol	Min.	Max.	Unit	Note
Power Supply Voltage	VDD	0	13.5	V	—
Input Voltage for logic	VI	-0.3	3.6	V	1)
Electrostatic Durability	VESD0	±100		V	2),3)
	VESD1	±8		kV	2),4)

Notes 1) It is applied to pixel data signal and clock signal.

2) Discharge Coefficient: 200pF-250Ω, Environmental: 25°C-70%RH

3) It is applied to I/F connector pins.

4) It is applied to the surface of a metallic bezel and a LCD panel.

(2) Back-light

Item	Symbol	Min.	Max.	Unit	Note
Input Current	IL		7.5	mA	1)
Input Voltage	VL	—	1800	Vrms	2)

Notes 1) The specification shall be applied to each CFL. The specification is defined at ground line.

2) The specification shall be applied at connector pins for a CFL at start-up.

2. OPTICAL CHARACTERISTICS

The following optical characteristics are measured when the LCD is set alone (apart from driving circuits and monitor cabinets) and under stable conditions. It takes about 30 minutes to reach stable conditions. The measuring point is the center of display area unless otherwise noted.

The optical characteristics should be measured in a dark room or equivalent state.

Measuring equipment: Prichard 1980A, or equivalent [N.I.S.T (Standard Source A)]

Environmental Temperature = 25°C, VDD=12.0V, fV=60Hz,

IL=7.0mA (average of 6 pieces of CFLs)

Item		Symbol	Condition	Min.	Typ.	Max.	Unit	Note
Contrast Ratio		CR	$\theta = 0^\circ$ 1)	300	550	—	—	2)
Response Time	Rise	ton		—	16	20	ms	3)
	Fall	toff		—	14	19		
Brightness of white		Bwh		220	280	—	cd/m ²	—
Brightness uniformity		Buni		—	—	25	%	4)
Color Chromaticity (CIE)	Red	x	$\theta = +50^\circ$ $\phi = 0^\circ, 90^\circ, 180^\circ, 270^\circ$ 1)	0.61	0.64	0.67	—	[Gray scale = 255]
		y		0.30	0.33	0.36		
	Green	x		0.26	0.29	0.32		
		y		0.57	0.60	0.63		
	Blue	x		0.12	0.15	0.18		
		y		0.03	0.06	0.09		
	White	x		0.28	0.31	0.34		
		y		0.30	0.33	0.36		
Variation of Color Position (CIE)	Red	Δx	$\theta = +50^\circ$ $\phi = 0^\circ, 90^\circ, 180^\circ, 270^\circ$ 1)	—	—	0.04	—	[Gray scale = 255]
		Δy		—	—	0.04		
	Green	Δx		—	—	0.04		
		Δy		—	—	0.04		
	Blue	Δx		—	—	0.04		
		Δy		—	—	0.04		
	White	Δx		—	—	0.04		
		Δy		—	—	0.04		
Contrast Ratio at 85°		CR85°	$\theta = +85^\circ$ $\phi = 0^\circ, 90^\circ, 180^\circ, 270^\circ$ 1)	10	—	—	—	—

Notes 1) Definition of Viewing Angle

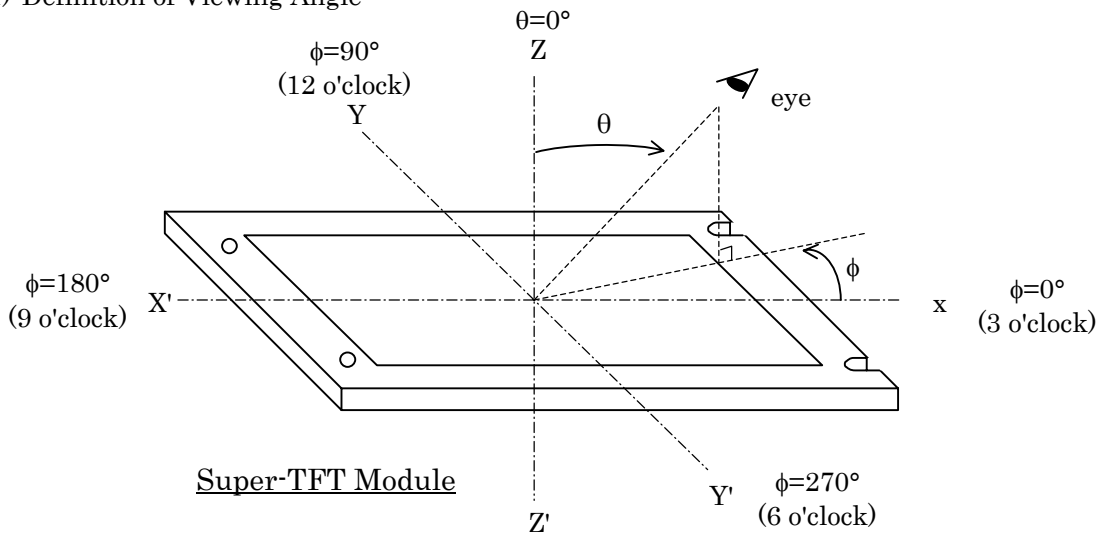

2) Definition of Contrast Ratio (CR)

$$CR = \frac{\text{(Luminance at displaying WHITE)}}{\text{(Luminance at displaying BLACK)}}$$

3) Definition of Response Time

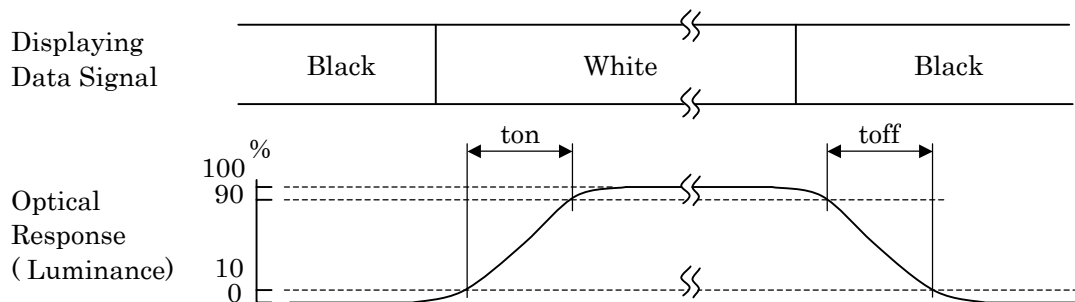

4) Definition of Brightness Uniformity

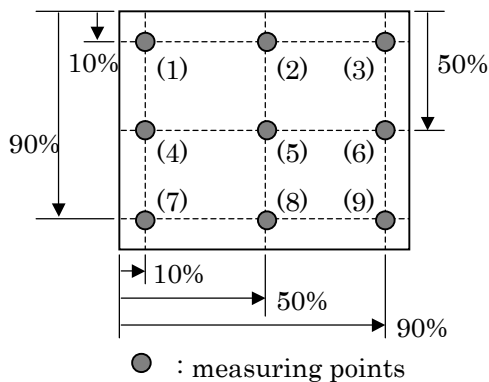

Display pattern is white (255 level). The brightness uniformity is defined as the following equation. Brightness at each point is measured, and average, maximum and minimum brightness is calculated.

$$Buni = \frac{|B_{max} \text{ or } B_{min} - B_{ave}|}{B_{ave}} \times 100$$

where, B_{max} = Maximum brightness

B_{min} = Minimum brightness

B_{ave} = Average brightness = $\frac{\sum_{k=1}^9 (B(k))}{9}$

5) Variation of color position on CIE is defined as difference between colors at $\theta = 0^\circ$ and at $\theta = 50^\circ$ & $\phi = 0^\circ, 90^\circ, 180^\circ, 270^\circ$.

3. ELECTRICAL CHARACTERISTICS

3.1 TFT-LCD MODULE

Ta=25°C, Vss=0V

Item	Symbol	Min.	Typ.	Max.	Unit	Note
Power Supply Voltage	VDD	11.0	12.0	13.0	V	—
Power Supply Current	IDD	—	0.5	(0.7)	A	1),2),3)
Vsync Frequency	fV	57	60	63	Hz	—
Hsync Frequency	fH	—	72	(75)	kHz	—
DCLK Frequency	fCLK	40	67.5	(81)	MHz	—

Dimensions in parentheses are reference value.

Notes 1) DC current at fv=60Hz, fCLK=67.5MHz and VDD=12V

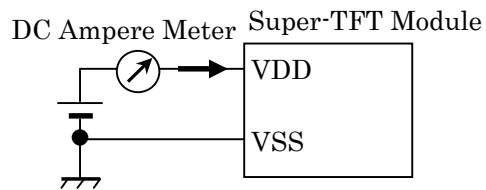

- 2) Current capacity of power supply for VDD should be larger than 5A, so that the fuse can be opened at the trouble of power supply.
- 3) The picture on maximum current is white picture.

3.2 BACK LIGHT

Item	Symbol	Min.	Typ.	Max.	Unit	Note
Input Current	IL	3.0	6.5	7.0	mArms	1)
Input Voltage	VL	—	800	—	Vrms	
Frequency	f0	40	54	65	kHz	2)
Kick-Off Voltage	Vs	1,500	—	1,750	V	3)

Notes 1) The specification shall be applied to each CFL. The specification is defined at ground line.

- 2) Frequency of power supply for a CFL may cause the interference with HSYNC frequency and cause beat or flicker on the display. Therefore, lamp frequency shall be as different as possible from HSYNC frequency in order to avoid the interference.
- 3) Ta = 0°C

4. BLOCK DIAGRAM

(1) Super-TFT Module

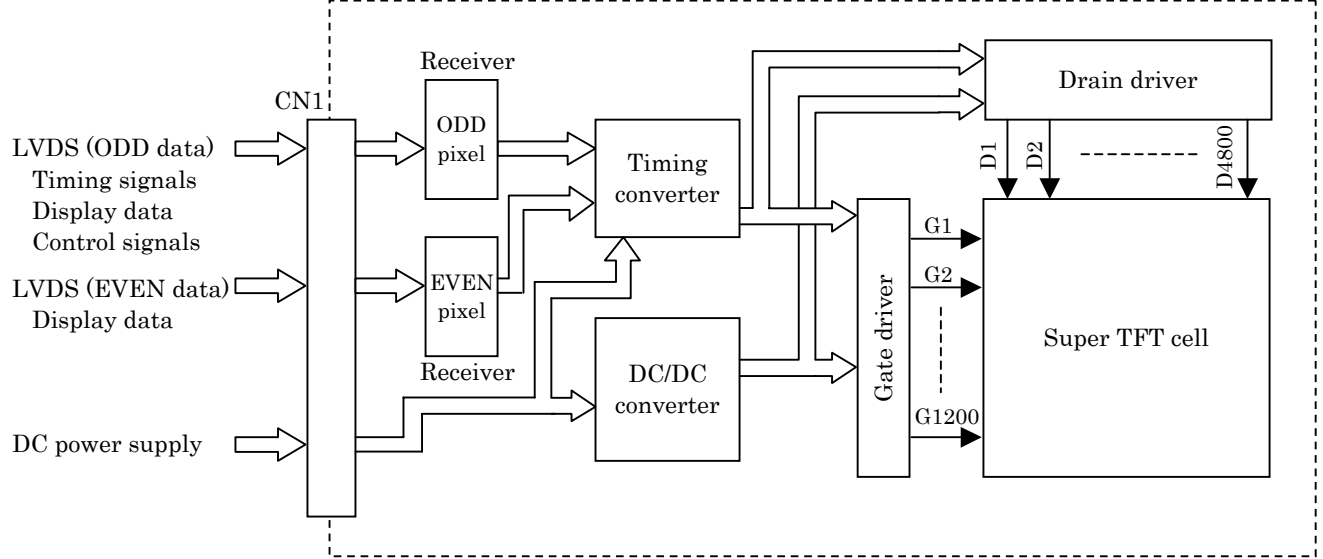

(2) Back light unit

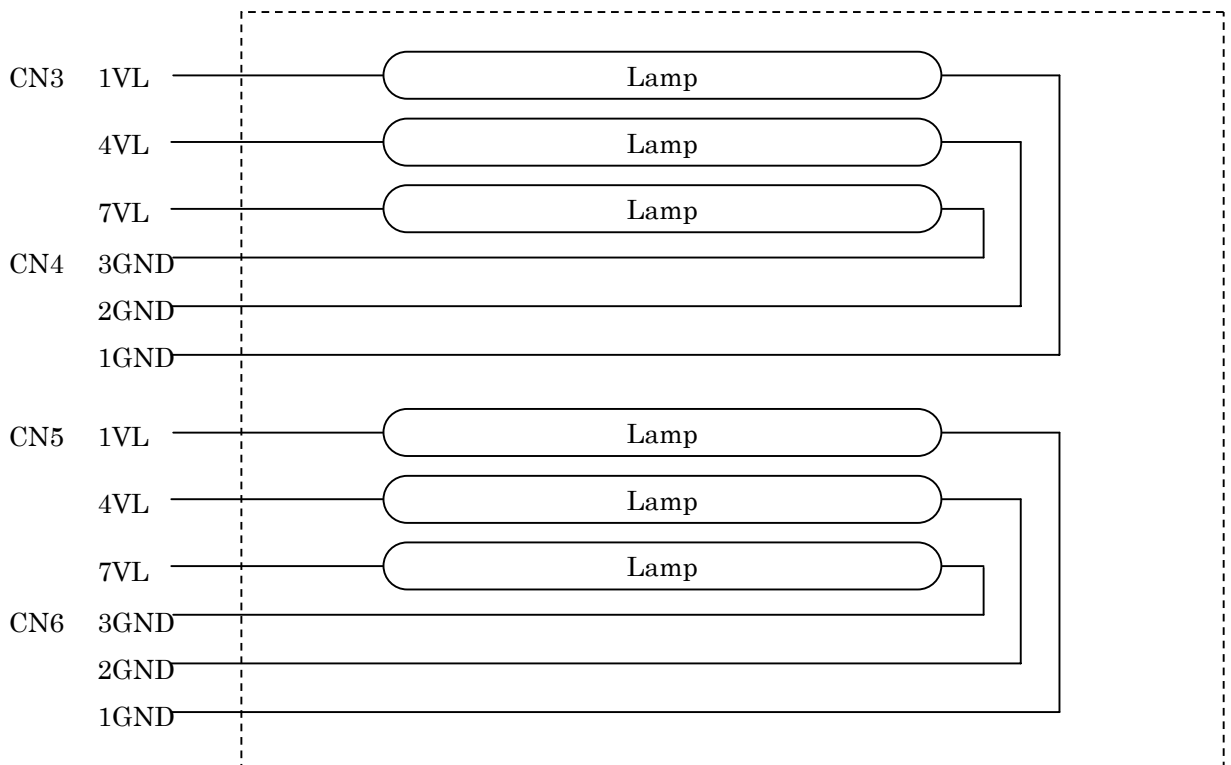

5. INTERFACE PIN ASSIGNMENT

5.1 TFT-LCD MODULE

CN1: JAE: FI-X30S-HF

(Matching connector: JAE FI-X30H or FI-X30M)

Pin No.	Symbol	Function	Note
1	RAIN0-	ODD pixel data	2)
2	RAIN0+		
3	RAIN1-	ODD pixel data	2)
4	RAIN1+		
5	RAIN2-	ODD pixel data	2)
6	RAIN2+		
7	V _{ss}	GND (0V)	1)
8	RACLKIN-	ODD pixel clock	2)
9	RACLKIN+		
10	RAIN3-	ODD pixel data	2)
11	RAIN3+		
12	RBIN0-	EVEN pixel data	2)
13	RBIN0+		
14	V _{ss}	GND (0V)	1)
15	RBIN1-	EVEN pixel data	2)
16	RBIN1+		
17	V _{ss}	GND (0V)	1)
18	RBIN2-	EVEN pixel data	2)
19	RBIN2+		
20	RBCLKIN-	EVEN pixel clock	2)
21	RBCLKIN+		
22	RBIN3-	EVEN pixel data	2)
23	RBIN3+		
24	V _{ss}	GND (0V)	1)
25	NC	No connection	3)
26	DE	No connection	3)
27	NC	No connection	3)
28	VDD	Power supply (12V)	4)
29	VDD		
30	VDD		

Notes 1) All V_{ss} pins should be grounded.

2) R_nIN_m⁺ and R_nIN_m⁻ (n=A,B m=0,1,2,3) should be wired by twist-pairs or side-by-side FPC patterns, respectively.

3) Please keep open.

4) All VDD pins should be connected to +12.0 V (typ.).

5) Pin assignment is as follows.

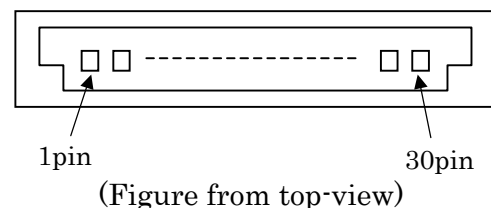

5.2 BACK-LIGHT UNIT

CN3, CN5: JST XHP-7

(Matching connector: S7B-HX-A, JST B7B-XH-A or B7B-XH-2)

Pin No.	Symbol	Function	Note
1	VL	Power Supply	1)
2	NC	No connection	
3	NC	No connection	
4	VL	Power Supply	1)
5	NC	No connection	
6	NC	No connection	
7	VL	Power Supply	1)

CN4, CN6: JST BHR-03VS-1

(Matching connector: SM03(4.0)B-BHS-1-TB)

Pin No.	Symbol	Function	Note
1	GND	GND	1)
2	GND	GND	1)
3	GND	GND	1)

Notes 1) There are parasitic capacitors between 3CCFLs. The different capacitance of these parasitic capacitors send the one-sided electric current to the specific CCFL. This phenomenon causes the drop of the optical characteristics.

To avoid this phenomenon, The inverter driving CCFLs should be applied as follows:

- (1) One transformer should cover to supply VL and IL for only one CCFL.
- (2) Providing detector to monitor IL current level for every each CCFL is recommended, but monitoring of only maximum current level among the 3CCFLs is also acceptable if the recommendation is not easily implemented at design of a inverter.

BLOCK DIAGRAM OF INTERFACE

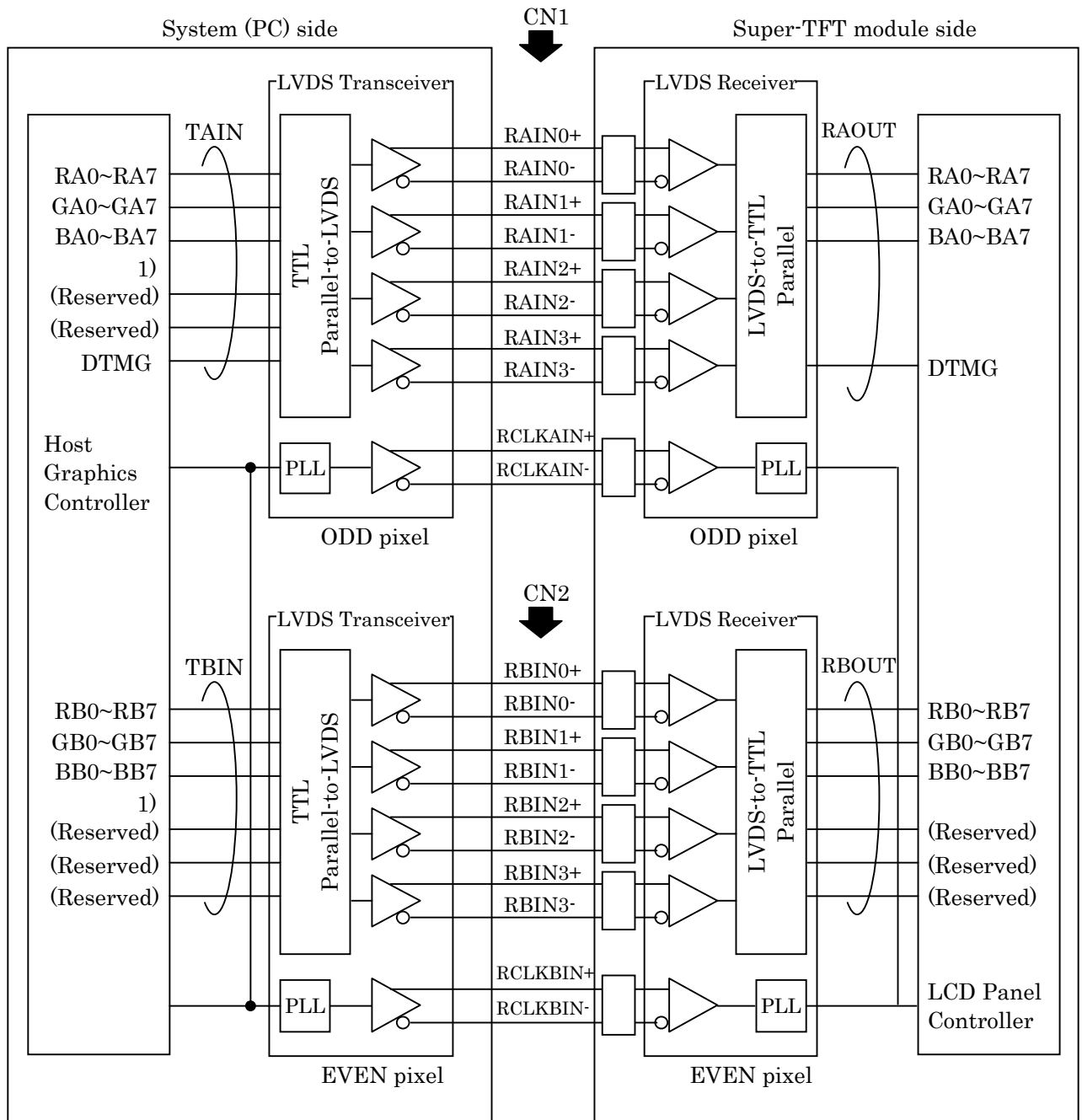

RA0~7, RB0~7 : R data
 GA0~7, GB0~7 : G data
 BA0~7, BB0~7 : B data
 DTMG : Display timing data

Receiver: Equivalent of THC63LVDF84B by Thine

- Notes
- 1) RSVD (reserved) pins on a transmitter should be connected with Vss.
 - 2) The system must have a LVDS transmitter to drive a module.
 - 3) The impedance of LVDS cable should be 50 ohms per a signal line or about 100 ohms per a twist-pair line when it is used differentially.

LVDS INTERFACE

	Input Signal	Transmitter		Interface connector		Receiver		TFT
		Pin	Input	System side	Super-TFT module	Pin	Output	Control input
LVDS Odd	RA0	51	TAIN0	TA OUT0+	RA IN0+	27	RAOUT0	RA0
	RA1	52	TAIN1			29	RAOUT1	RA1
	RA2	54	TAIN2			30	RAOUT2	RA2
	RA3	55	TAIN3			32	RAOUT3	RA3
	RA4	56	TAIN4	TA OUT0-	RA IN0-	33	RAOUT4	RA4
	RA5	3	TAIN6			35	RAOUT6	RA5
	GA0	4	TAIN7			37	RAOUT7	GA0
	GA1	6	TAIN8			38	RAOUT8	GA1
	GA2	7	TAIN9	TA OUT1+	RA IN1+	39	RAOUT9	GA2
	GA3	11	TAIN12			43	RAOUT12	GA3
	GA4	12	TAIN13			45	RAOUT13	GA4
	GA5	14	TAIN14			46	RAOUT14	GA5
	BA0	15	TAIN15	TA OUT1-	RA IN1-	47	RAOUT15	BA0
	BA1	19	TAIN18			51	RAOUT18	BA1
	BA2	20	TAIN19			53	RAOUT19	BA2
	BA3	22	TAIN20			54	RAOUT20	BA3
	BA4	23	TAIN21	TA OUT2+	RA IN2+	55	RAOUT21	BA4
	BA5	24	TAIN22			1	RAOUT22	BA5
	RSVD 1)	27	TAIN24			3	RAOUT24	RSVD
	RSVD 1)	28	TAIN25			5	RAOUT25	RSVD
	DTMG	30	TAIN26	TA OUT2-	RA IN2-	6	RAOUT26	DTMG
	RA6	50	TAIN27			7	RAOUT27	RA6
	RA7	2	TAIN5			34	RAOUT5	RA7
	GA6	8	TAIN10			41	RAOUT10	GA6
	GA7	10	TAIN11	TA OUT3+	RA IN3+	42	RAOUT11	GA7
	BA6	16	TAIN16			49	RAOUT16	BA6
BA7	18	TAIN17	50			RAOUT17	BA7	
RSVD 1)	25	TAIN23	2			RAOUT23	RSVD	
	DCLK	31	TCLKA IN	TCLKA OUT+	RCLKA IN+	26	RCLKA OUT	DCLK
				TCLKA OUT-	RCLKA IN-			
LVDS Even	RB0	51	TBIN0	TB OUT0+	RB IN0+	27	RBOUT0	RB0
	RB1	52	TBIN1			29	RBOUT1	RB1
	RB2	54	TBIN2			30	RBOUT2	RB2
	RB3	55	TBIN3			32	RBOUT3	RB3
	RB4	56	TBIN4	TB OUT0-	RB IN0-	33	RBOUT4	RB4
	RB5	3	TBIN6			35	RBOUT6	RB5
	GB0	4	TBIN7			37	RBOUT7	GB0
	GB1	6	TBIN8			38	RBOUT8	GB1
	GB2	7	TBIN9	TB OUT1+	RB IN1+	39	RBOUT9	GB2
	GB3	11	TBIN12			43	RBOUT12	GB3
	GB4	12	TBIN13			45	RBOUT13	GB4
	GB5	14	TBIN14			46	RBOUT14	GB5
	BB0	15	TBIN15	TB OUT1-	RB IN1-	47	RBOUT15	BB0
	BB1	19	TBIN18			51	RBOUT18	BB1
	BB2	20	TBIN19			53	RBOUT19	BB2
	BB3	22	TBIN20			54	RBOUT20	BB3
	BB4	23	TBIN21	TB OUT2+	RB IN2+	55	RBOUT21	BB4
	BB5	24	TBIN22			1	RBOUT22	BB5
	RSVD 1)	27	TBIN24			3	RBOUT24	RSVD
	RSVD 1)	28	TBIN25			5	RBOUT25	RSVD
	RSVD 1)	30	TBIN26	TB OUT2-	RB IN2-	6	RBOUT26	RSVD
	RB6	50	TBIN27			7	RBOUT27	RB6
	RB7	2	TBIN5			34	RBOUT5	RB7
	GB6	8	TBIN10			41	RBOUT10	GB6
	GB7	10	TBIN11	TB OUT3+	RB IN3+	42	RBOUT11	GB7
	BB6	16	TBIN16			49	RBOUT16	BB6
BB7	18	TBIN17	50			RBOUT17	BB7	
RSVD 1)	25	TBIN23	2			RBOUT23	RSVD	
	DCLK	31	TCLKB IN	TCLKB OUT+	RCLKB IN+	26	RCLKB OUT	DCLK
				TCLKB OUT-	RCLKB IN-			

CORRESPONDENCE BETWEEN INPUT DATA AND DISPLAY IMAGE

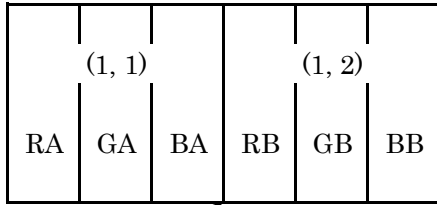

Odd pixel: RA0~RA7 : R data
 GA0~GA7 : G data
 BA0~BA7 : B data

Even pixel: RB0~RB7 : R data
 GB0~GB7 : G data
 BB0~BB7 : B data

1, 1	1, 2	1, 3	1, 1600
2, 1	2, 2	2, 3	2, 1600
3, 1	3, 2	3, 3	3, 1600
⋮	⋮	⋮		⋮
1200, 1	1200, 2	1200, 3	1200, 1600

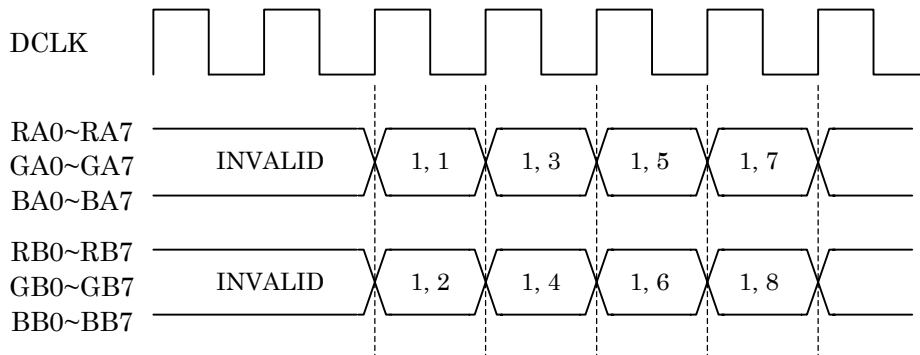

RELATIONSHIP BETWEEN DISPLAY COLORS AND INPUT SIGNALS

Input data		R data								G data								B data															
		RA7	RA6	RA5	RA4	RA3	RA2	RA1	RA0	GA7	GA6	GA5	GA4	GA3	GA2	GA1	GA0	BA7	BA6	BA5	BA4	BA3	BA2	BA1	BA0								
Color		RB7	RB6	RB5	RB4	RB3	RB2	RB1	RB0	GB7	GB6	GB5	GB4	GB3	GB2	GB1	GB0	BB7	BB6	BB5	BB4	BB3	BB2	BB1	BB0								
		MSB								LSB								MSB								LSB							
BASIC COLOR	BLACK	0	0	0	0	0	0	0	0	0	0	0	0	0	0	0	0	0	0	0	0	0	0	0	0								
	RED (255)	1	1	1	1	1	1	1	1	0	0	0	0	0	0	0	0	0	0	0	0	0	0	0	0								
	GREEN (255)	0	0	0	0	0	0	0	0	1	1	1	1	1	1	1	1	0	0	0	0	0	0	0	0								
	BLUE (255)	0	0	0	0	0	0	0	0	0	0	0	0	0	0	0	0	1	1	1	1	1	1	1	1								
	CYAN	0	0	0	0	0	0	0	0	1	1	1	1	1	1	1	1	1	1	1	1	1	1	1	1								
	MAGENTA	1	1	1	1	1	1	1	1	0	0	0	0	0	0	0	0	1	1	1	1	1	1	1	1								
	YELLOW	1	1	1	1	1	1	1	1	1	1	1	1	1	1	1	1	0	0	0	0	0	0	0	0								
	WHITE	1	1	1	1	1	1	1	1	1	1	1	1	1	1	1	1	1	1	1	1	1	1	1	1								
RED	BLACK	0	0	0	0	0	0	0	0	0	0	0	0	0	0	0	0	0	0	0	0	0	0	0	0								
	RED (1)	0	0	0	0	0	0	0	1	0	0	0	0	0	0	0	0	0	0	0	0	0	0	0	0								
	RED (2)	0	0	0	0	0	0	1	0	0	0	0	0	0	0	0	0	0	0	0	0	0	0	0	0								
	⋮	⋮	⋮	⋮	⋮	⋮	⋮	⋮	⋮	⋮	⋮	⋮	⋮	⋮	⋮	⋮	⋮	⋮	⋮	⋮	⋮	⋮	⋮	⋮	⋮								
	⋮	⋮	⋮	⋮	⋮	⋮	⋮	⋮	⋮	⋮	⋮	⋮	⋮	⋮	⋮	⋮	⋮	⋮	⋮	⋮	⋮	⋮	⋮	⋮	⋮								
	RED (254)	1	1	1	1	1	1	1	0	0	0	0	0	0	0	0	0	0	0	0	0	0	0	0	0								
	RED (255)	1	1	1	1	1	1	1	1	0	0	0	0	0	0	0	0	0	0	0	0	0	0	0	0								
GREEN	BLACK	0	0	0	0	0	0	0	0	0	0	0	0	0	0	0	0	0	0	0	0	0	0	0	0								
	GREEN (1)	0	0	0	0	0	0	0	0	0	0	0	0	0	0	0	1	0	0	0	0	0	0	0	0								
	GREEN (2)	0	0	0	0	0	0	0	0	0	0	0	0	0	0	1	0	0	0	0	0	0	0	0	0								
	⋮	⋮	⋮	⋮	⋮	⋮	⋮	⋮	⋮	⋮	⋮	⋮	⋮	⋮	⋮	⋮	⋮	⋮	⋮	⋮	⋮	⋮	⋮	⋮	⋮								
	⋮	⋮	⋮	⋮	⋮	⋮	⋮	⋮	⋮	⋮	⋮	⋮	⋮	⋮	⋮	⋮	⋮	⋮	⋮	⋮	⋮	⋮	⋮	⋮	⋮								
	GREEN (254)	0	0	0	0	0	0	0	0	1	1	1	1	1	1	1	0	0	0	0	0	0	0	0	0								
	GREEN (255)	0	0	0	0	0	0	0	0	1	1	1	1	1	1	1	1	0	0	0	0	0	0	0	0								
BLUE	BLACK	0	0	0	0	0	0	0	0	0	0	0	0	0	0	0	0	0	0	0	0	0	0	0	0								
	BLUE (1)	0	0	0	0	0	0	0	0	0	0	0	0	0	0	0	0	0	0	0	0	0	0	0	1								
	BLUE (2)	0	0	0	0	0	0	0	0	0	0	0	0	0	0	0	0	0	0	0	0	0	0	1	0								
	⋮	⋮	⋮	⋮	⋮	⋮	⋮	⋮	⋮	⋮	⋮	⋮	⋮	⋮	⋮	⋮	⋮	⋮	⋮	⋮	⋮	⋮	⋮	⋮	⋮								
	⋮	⋮	⋮	⋮	⋮	⋮	⋮	⋮	⋮	⋮	⋮	⋮	⋮	⋮	⋮	⋮	⋮	⋮	⋮	⋮	⋮	⋮	⋮	⋮	⋮								
	BLUE (254)	0	0	0	0	0	0	0	0	0	0	0	0	0	0	0	0	1	1	1	1	1	1	1	0								
	BLUE (255)	0	0	0	0	0	0	0	0	0	0	0	0	0	0	0	0	1	1	1	1	1	1	1	1								

Notes 1) Definition of gray scale: Color (n)

n indicates gray scale level. Higher n means brighter level.

2) Data signals: 1: High, 0: Low

6. TIMING DIAGRAMS OF INTERFACE TIMING

6.1 TIMING DIAGRAMS OF INTERFACE SIGNAL

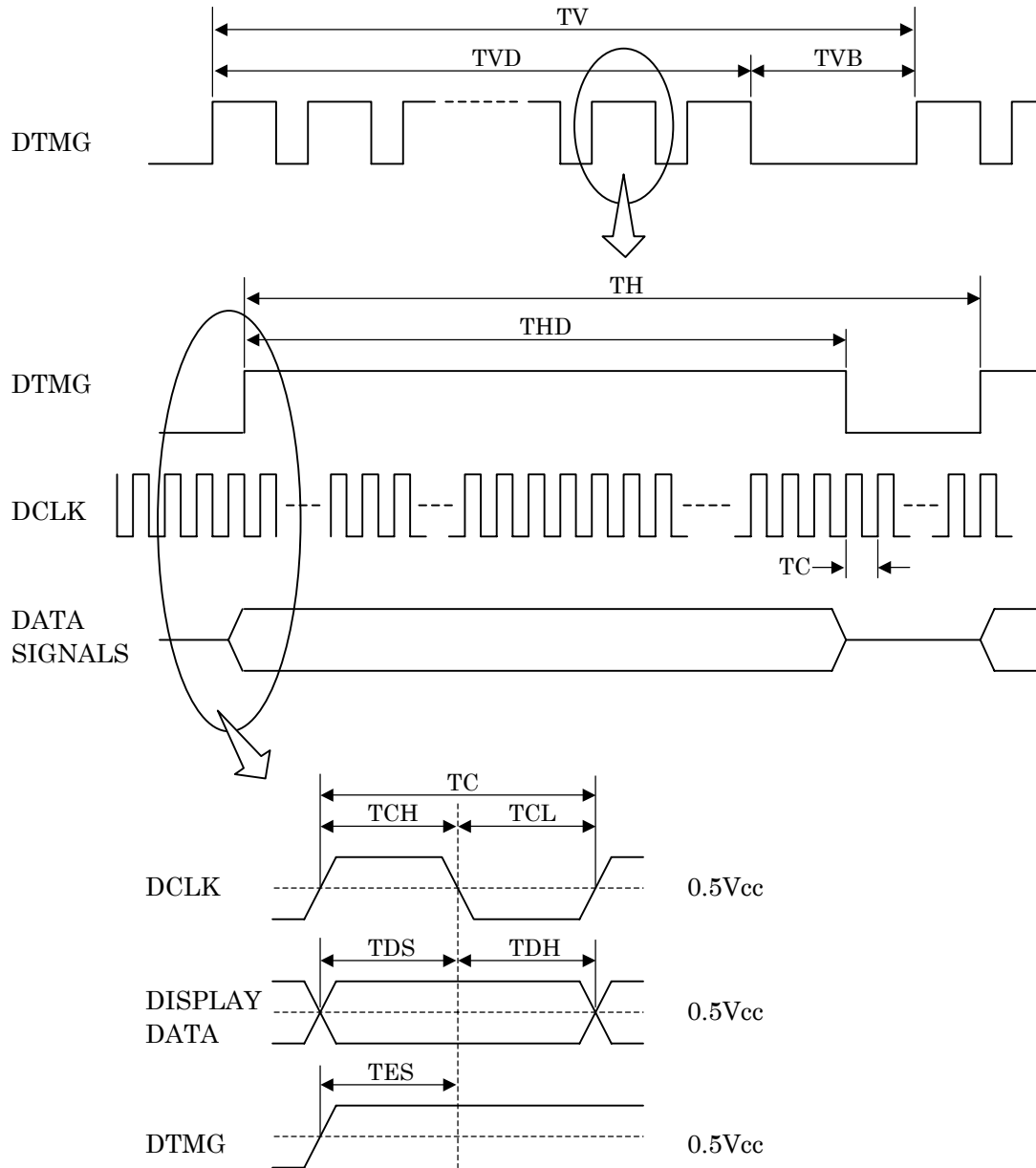

6.2 TIMING PARAMETERS

2pxl/clk

Signal	Item	Symbol	Min.	Typ.	Max.	Unit	Note
Clock	Frequency	1/Tc	40	67.5	(81)	MHz	—
	High Time	TCH	4	—	—	nsec	
	Low Time	TCL	4	—	—	nsec	
Data	Setup Time	TDS	4	—	—	nsec	
	Hold Time	TDH	4	—	—	nsec	
DTMG	Setup Time	TES	4	—	—	nsec	
Frame Frequency	Cycle	TV	(15.9)	16.7	(17.5)	msec	—
			1,203	1,203	(1,270)	lines	
Vertical Active Display Term	Display Period	TVD	1,200	1,200	1,200	lines	—
	Vertical Blank Period	TVB	3	3	(70)	lines	—
One Line Scanning Time	Cycle	TH	840	936	(1,080)	clocks	—
Horizontal Active Display Term	Display Period	THD	800	800	880	clocks	—

6.3 TIMING BETWEEN INTERFACE SIGNALS AND POWER SUPPLY

Power supply voltage VDD

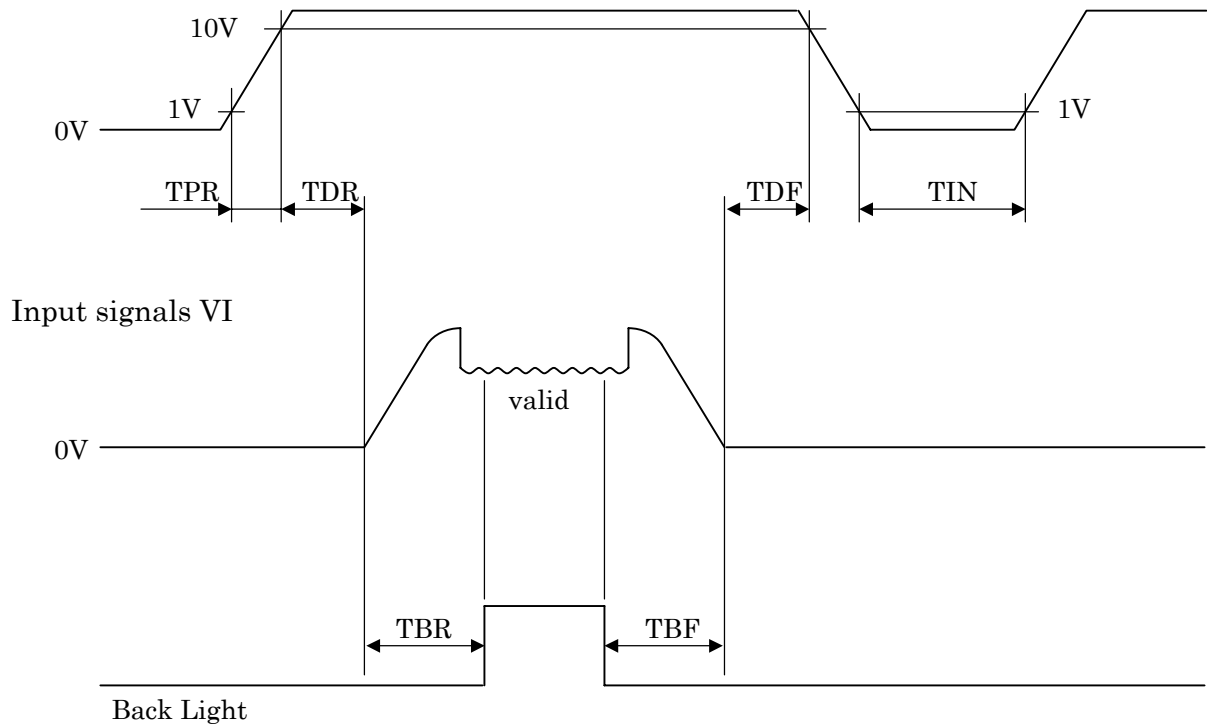

Timing of power supply voltage and input signals should be used under the following specifications.

$$\begin{aligned}
 0\text{ms} &\leq \text{TPR} \leq 10\text{ms} \\
 10\text{ms} &\leq \text{TDR} \leq 50\text{ms} \\
 0\text{ms} &\leq \text{TDF} \leq 50\text{ms} \\
 \text{TIN} &\geq 1\text{s} \\
 \text{TBR} &\leq 500\text{ms} \\
 \text{TBF} &\leq 100\text{ms}
 \end{aligned}$$

Front View

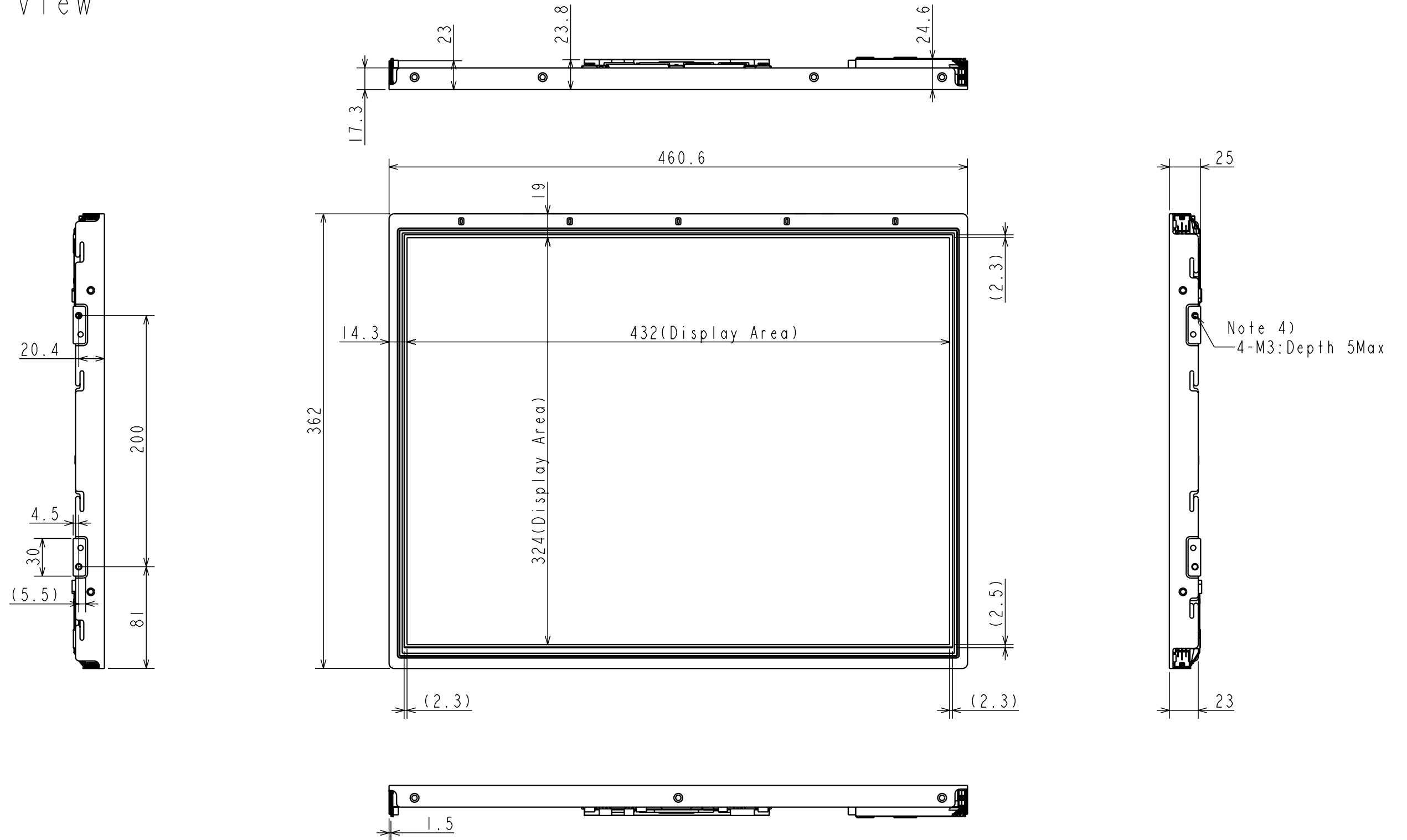

- Note 1) Dimension in parentheses are reference value.
 2) Tolerance not specified is +/-0.5mm
 3) Measure the thickness with $9.8 \times 10^4 \text{ Pa}$ (1.0 kgf/cm^2) Pressure.
 4) Maximum torque for the screw in mounting module: 0.588Nm

Rear View

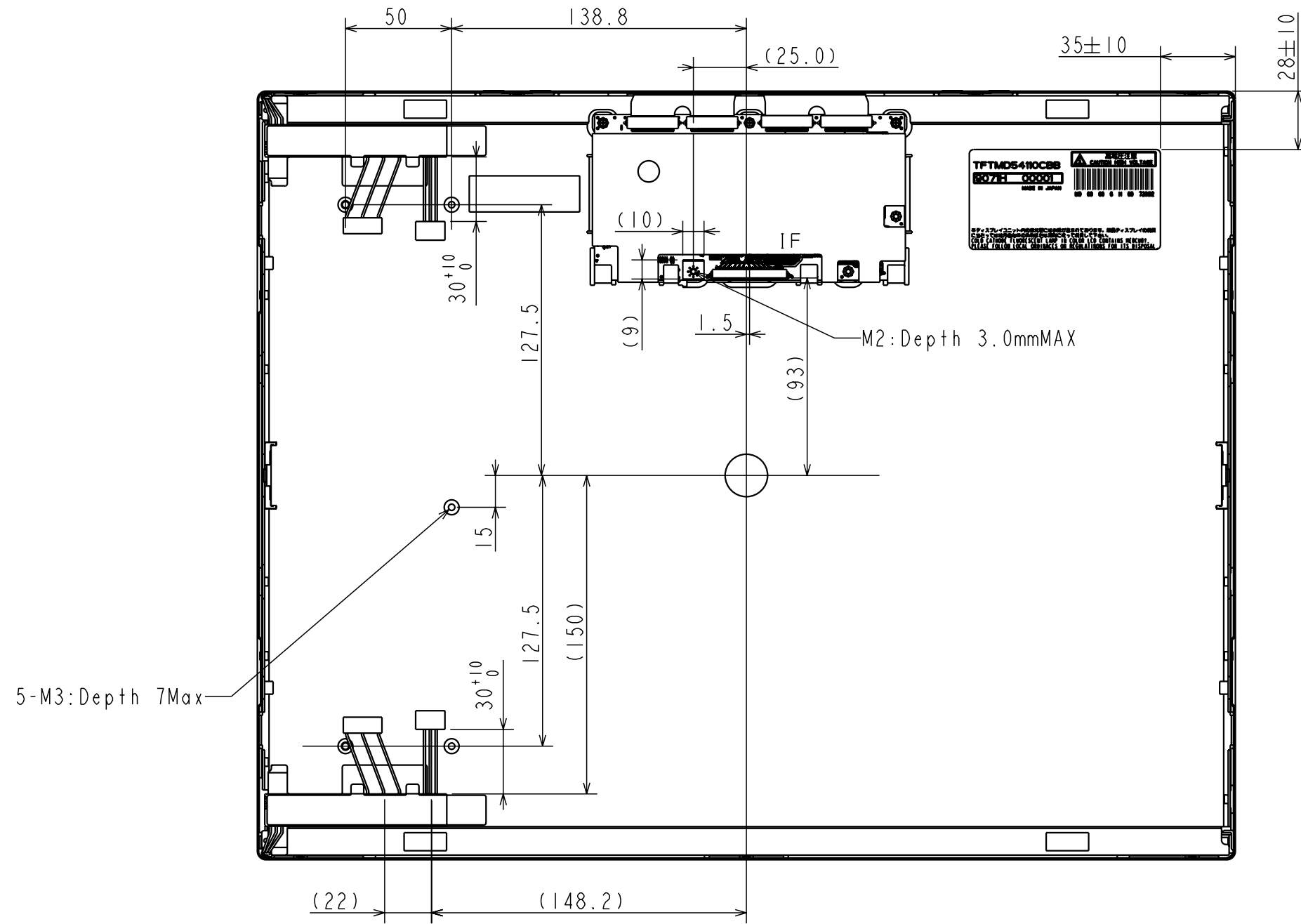

8. DESIGNATION OF LOT MARK

8.1 LOT MARK

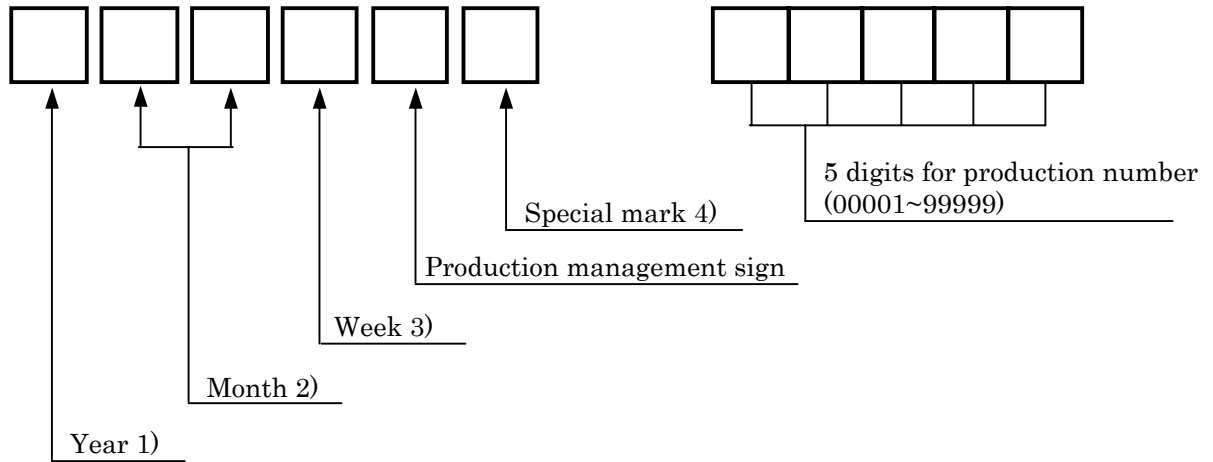

Notes

1)

Year	Mark
2009	9
2010	0
2011	1
2012	2

2)

Month	Mark	Month	Mark
1	01	7	07
2	02	8	08
3	03	9	09
4	04	10	10
5	05	11	11
6	06	12	12

3)

Week (Days)	Mark
1~7	1
8~14	2
15~21	3
22~28	4
29~31	5

4) It is the mark that was opened up by production person to take correspondence with production number.

8.2 LOCATION OF LOT MARK

Lot mark is printed on a label. The label is on the metallic bezel as shown in 7. External Dimensional. The style of character will be changed without notice.

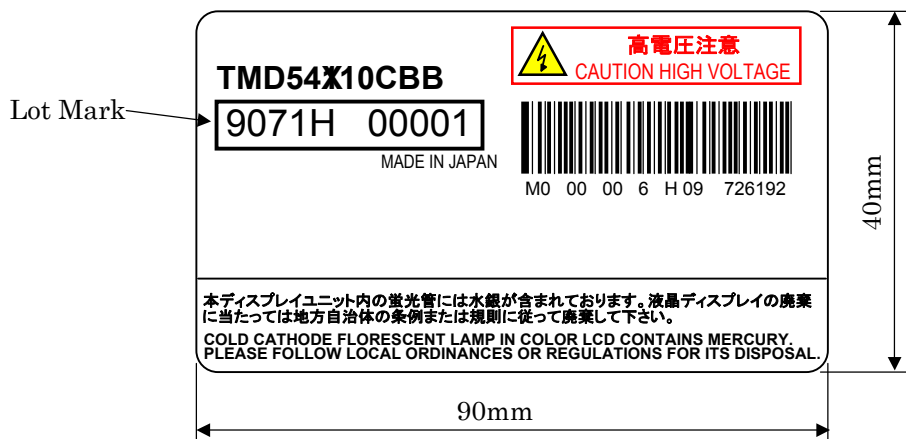

10. PRECAUTION

Please pay close attention to the following precautions whilst using, handling and mounting the TFT module.

10.1 PRECAUTION FOR HANDLING AND MOUNTING

- (1) Applying excessive force to any part of the module may result in partial deformation of the frame or mould, which could result in permanent damage to the display.
- (2) The module should be held gently and firmly using both hands. In order to avoid internal damage never hold the module by just one hand. Also never drop or hit the module.
- (3) The module should be installed using the mounting holes of the module.
- (4) Uneven force such as twisted stress should not be applied directly to the module once it is mounted within the cover case. The cover case must have sufficient strength such that any external forces are not transmitted directly to the module.
- (5) It is recommended that you maintain a gap between the display module and the rear chassis so as to avoid any mechanical stress being passed to the module.

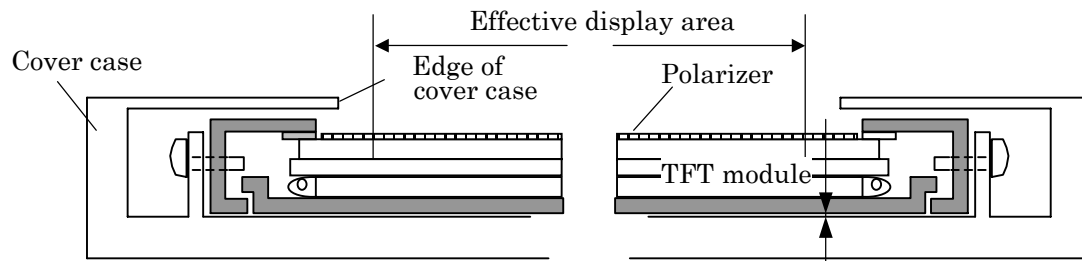

Fig.1 Cross sectional view of a monitor set above precaution (5)

- (6) The edge of the cover case should be positioned with more than a 1mm overlap from the edge of the module's upper frame.
- (7) A transparent protective plate should be added to the front of the display in order to protect both the polarizer and TFT cell. The transparent protective plate should have sufficient strength such that the plate can not be deformed, due to external forces, and touch the module. Polarizer surface hardness is H.
- (8) Materials containing acetic acid and chlorine should not be used for the cover case nor for other parts which are positioned in close proximity to the module. This is because the Acetic acid will attack the polarizer, whilst the chlorine will attack the electric circuits by way of electro-chemical reaction.
- (9) The front polarizer on the TFT cell should be handled carefully, due to its softness, and must not be touched, pushed or rubbed with glass, tweezers or anything harder than an HB pencil lead.
The surface of the polarizer should not be touched nor rubbed with bare hands, greasy or dusty clothes.
- (10) If the surface of polarizer becomes dirty, it should be softly wiped off by absorbent cotton, chamois or other soft material with recommended potion. Do not rub strongly to avoid damaging the surface. IPA (isopropyl alcohol) is recommended to clean away the traces of adhesive which is used to attach the front/rear polarizers to the TFT cell. Other cleaning chemicals such as acetone, toluene and alcohol should not be used to clean adhesives because they cause chemical damage to the polarizer.
- (11) Saliva or water drops should be immediately wiped off. Otherwise, the affected portion of the polarizer may become deformed and its color may fade.
- (12) The module should not be opened or modified, under any circumstances, as this may cause it to

(13) The metallic bezel of the module should not be handled with bare hand or dirty gloves. Otherwise, the color of the metallic frame may become dirty during its storage. It is recommended to use clean soft gloves and clean finger stalls whilst the module is handled during incoming inspection and production assembly processes.

(14) CCFL cables should not be used to hold the module or pulled.

10.2 PRECAUTION TO OPERATION

(1) Heat from the backlight could raise the temperature of TFT-LCD module (TFT-LCD panel). Therefore, the mechanism of radiating heat is necessary to satisfy environmental specification of this module.

(2) Spike noise could result in the miss-operation of this module. The level of spike noise should be as follows: $-200\text{mV} \leq \text{over- and under- shoot of VDD} \leq +200\text{mV}$

VDD including over- and under- shoot should not exceed the absolute maximum ratings.

(3) Optical response times, luminance and chromaticity depend on the temperature of the TFT module. Response times and saturation times of CCFL luminance become longer at lower operating temperatures.

(4) The starting characteristic of the lamp will become worse at the low temperature.

(Loss time to obtain stable luminescence after inputting power will become long.)

(5) Sudden temperature changes may cause dew on and/or in the module. Dew can cause damage to the polarizer and/or electrical contacting areas of the module. Dew causes fading of the image quality.

(6) If same pattern is displayed for a long time, the image sticking might remain.

But it will become weak as a time goes on after displaying another image.

(7) This module has high frequency circuits. Sufficient suppression to electromagnetic interference should be done by the system manufacturers. Grounding and shielding methods may be effective to minimize such interference.

(8) Noise may be heard when the back-light is operated. If necessary, sufficient suppression should be done by the system manufacturers.

(9) Connecting or disconnecting the I/F cables, whilst the power and data signals are present, could result in permanent damage to the module. The I/F connectors should only be connected and disconnected after the power supply and data signal have been turned off.

10.3 ELECTROSTATIC DISCHARGE CONTROL

(1) This module consists of a TFT cell and electronic circuits with CMOS-ICs, which are very susceptible to electrostatic discharge. Persons who are handling the module should be grounded through adequate methods such as a wrist band. I/F connector pins should not be touched directly with bare hands.

(2) The polarizer protective film should be removed slowly so as to avoid an excessive build-up of electrostatic charge.

10.4 PRECAUTION TO STRONG LIGHT EXPOSURE

(1) The module should not be exposed to strong light. Otherwise, characteristics of the polarizer and color filter, may be degraded.

10.5 PRECAUTION TO STORAGE

When modules are stored, for long period's of time, the following precautions should be taken:

(1) Modules should be stored in a dark place. It is prohibited to apply direct sunlight or fluorescent light during storage. Modules should be stored between 15 to 35°C at normal humidity (60%RH or less).

(2) The surface of the polarizer should not come into direct contact with other objects.

It is recommended that modules should be stored in the original shipping box.

Hitachi Displays, Ltd.	Date	May. 29, 2009	Sh. No.	DPBCL0002037-1	Page	13-2/3
------------------------	------	---------------	------------	----------------	------	--------

10.6 PRECAUTION TO HANDLING PROTECTION FILM

- (1) The protective sheet for polarizers should be peeled off slowly and carefully by people who are electrically grounded with adequate methods such as wrist bands. Also ionized air should be blown over the module during the peeling action.
Dust on the polarizer should be blown off gently using an ionized nitrogen gun.

10.7 SAFETY

- (1) Since both the TFT cell and CCFL lamps are made of glass, handling of any broken module's should be carried out with the utmost care so as to avoid any injury. Hands which have come into direct contact with liquid crystal material should be washed immediately and thoroughly.
- (2) The module should not be taken apart during operation so that back-light drives by high voltage.
- (3) The inverter for driving CCFL should have over current/voltage detect circuit in case back-light failure happens. Also protection circuit (open, short, spark, etc) should be verified on inverter and system side.

10.8 ENVIRONMENTAL PROTECTION

- (1) The TFT module contains cold cathode fluorescent lamps. Please follow local ordinance or regulations for its disposal.

10.9 USE RESTRICTIONS AND LIMITATIONS

- (1) In no event shall Hitachi Displays, Ltd. be liable for any incidental, indirect or consequential damages in connection with the installation or use of this product, even if informed of the possibility there of in advance. These limitations apply to all causes action in aggregate, including without limitation breach of contract, breach of warranty, negligence, strict liability, misrepresentation and other torts.
- (2) This product is not authorized for military applications or other applications which pose a significant risk of personal injury.

10.10 OTHERS

- (1) Electronic parts that do not influence the electrical specification might be changed without notice.
- (2) Limited current circuit must be required for the inverter output.

Hitachi Displays, Ltd.	Date	May. 29, 2009	Sh. No.	DPBCL0002037-1	Page	13-3/3
------------------------	------	---------------	------------	----------------	------	--------