

High Brightness

5.7" Active Matrix Color LCD Module
TCG057VG1AC-H50

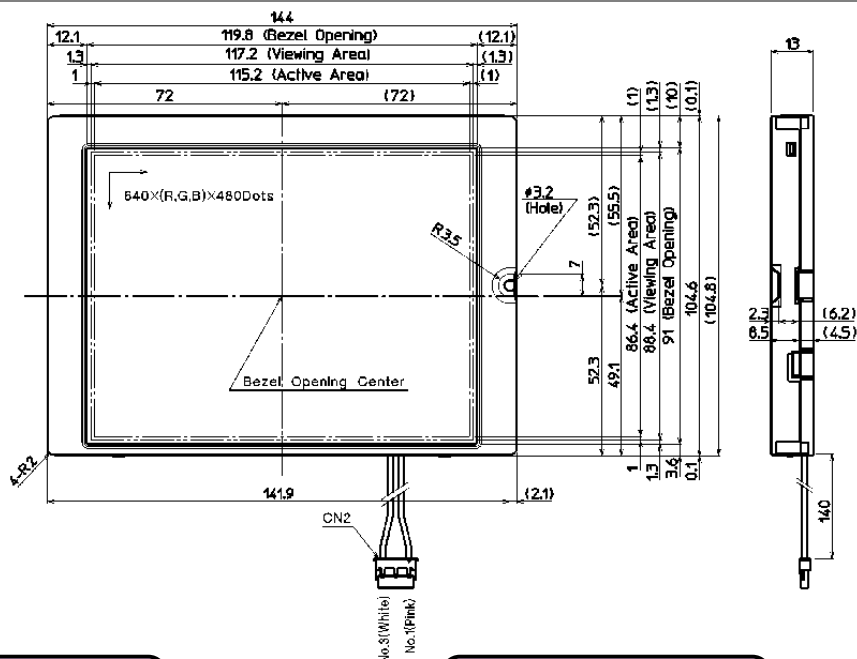

Features

- High Brightness (800cd/m²)
- RoHS Compliant
- Symmetrical Design(Horizontal)
- Single Power Supply (With DC/DC Converter)
- Long Life CFL 75,000(h)
- V Series Compatible Design (Outline)
 KG057QV --- Monochrome STN
 KCG057QV --- Color STN
 TCG057QV --- Color TFT

Applications

- Display for Industrial Machine
- Measuring Instrument, Chart Recorder, Scale
- POS, ATM, Bank Terminal
- Fish Finder, Musical Instrument, Sewing Machine
- Office Automation

Specification

ITEM	SPECIFICATION	UNIT
Dot Format	640 × (R, G, B) (W) × 480 (H)	dot
Dot Pitch	0.06 (W) × 0.18 (H)	mm
Outline Dimensions	144 (W) × (104.8) (H) × 13.0 (D)	mm
Mass	220	g
Contrast Ratio	400:1	—
Brightness	800 (IL=5.0mArms)	cd/m ²
Response Time	35	ms
Viewing Angle (V/H)	150/160 (CR ≥ 5)	deg.
Power Consumption	693 (LCD)	mW
	3.275 (Backlight)	W
Backlight	CFL (Single Tube)	—

ATTENTION : Specification subject to change without notice.
 Please check the latest version of the product specification.

KYOCERA CORPORATION
LCD Division

6 Takeda Tobadono-cho, Fushimi-ku, Kyoto 612-8501 Japan
 Phone: +81-75-604-3751 <http://www.kyocera.co.jp/lcd/>

- KYOCERA INDUSTRIAL CERAMICS CORPORATION (USA)
 Phone(Toll Free) : +1-800-826-0527 <http://www.kyocera.com/>
- KYOCERA FINECERAMICS GmbH (GERMANY)
 Phone : +49-711-939-3439 <http://www.kyocera.de/>
- KYOCERA FINECERAMICS S.A. (FRANCE)
 Phone : +33-1-45120239
- KYOCERA FINECERAMICS LTD. (UK)
 Phone : +44-1252-776000
- KYOCERA ASIA PACIFIC PTE. LTD. (SINGAPORE)
 Phone : +65-6271-0500
- KYOCERA ASIA PACIFIC PTE. LTD. TAIPEI BRANCH (TAIWAN)
 Phone : +886-2-2555-3609
- KYOCERA ASIA PACIFIC LTD. (HONG KONG)
 Phone : +852-2723-7183
- KYOCERA (Tianjin) SALES & TRADING CORPORATION. (CHINA)
 Phone : +86-10-8528-8838 ext.103