

Product Specification

SPECIFICATION FOR APPROVAL

- (●) Preliminary Specification
- () Final Specification

Title	3.5" (320 X RGB X 240) TFT- LCD
--------------	--

BUYER	
MODEL	

SUPPLIER	LG.Philips LCD CO.,Ltd.
MODEL	LB035Q02
SUFFIX	TD01-B51

SIGNATURE	DATE
/	_____
/	_____
/	_____

APPROVED BY	DATE
C. S. Kyeong /G. Manager	_____
REVIEWED BY	
S. H. Kim / Manager	_____
PREPARED BY	
H. S. Woo / Engineer	_____

**Product Engineering Dept.
LG. Philips LCD Co., Ltd**

Product Specification**Contents**

No.	Item	Page
0	Record of Revisions	3
1	General Description	4
2	Interface [Input Terminal]	6
3	Absolute Maximum Ratings	10
4	Electrical Characteristics	11
5	Optical Characteristics	12
6	Mechanical Characteristics	15
7	Operation Specifications	16
8	Power On/Off Sequence	22
9	Reliability Test	25
10	Outline Dimension	26
11	Packing	28
12	Marking & Others	30
13	Precautions	31
14	Production Center	32

Product Specification

RECORD OF REVISIONS

Revision No	Revision Date	Page	Description	Note
0.0	Feb. 11. 2007	-	First Draft (Preliminary)	
0.1	Mar. 02. 2007	7	Interface Connection (Pin Number 52~54)	
		8	Stabilization Capacitor (Recommend)	
0.2	April. 02. 2007	6~7	Interface Connection	
		8	Stabilization Capacitor & Diode (System)	
		9	Stabilization Capacitor (FPC)	
		15	Bezel Area changed	
		27	TSP PAD Pitch (1.0mm → 1.25mm)	

Product Specification

1. General Description

1-1. Description

The LB035Q02 is a Color Active Matrix Liquid Crystal Display with a white LED backlight assembly. The matrix employs a-Si Thin Film Transistor as the active element. It is a transmissive type display operating in the normally white mode. This module is a diagonal 3.5 inch with the Landscape typed QVGA resolution.

The LB035Q02 is intended to support displays. [PND(Portable Navigation Device), PMP(Portable Multimedia Player) and others]

1-2. Block Diagram

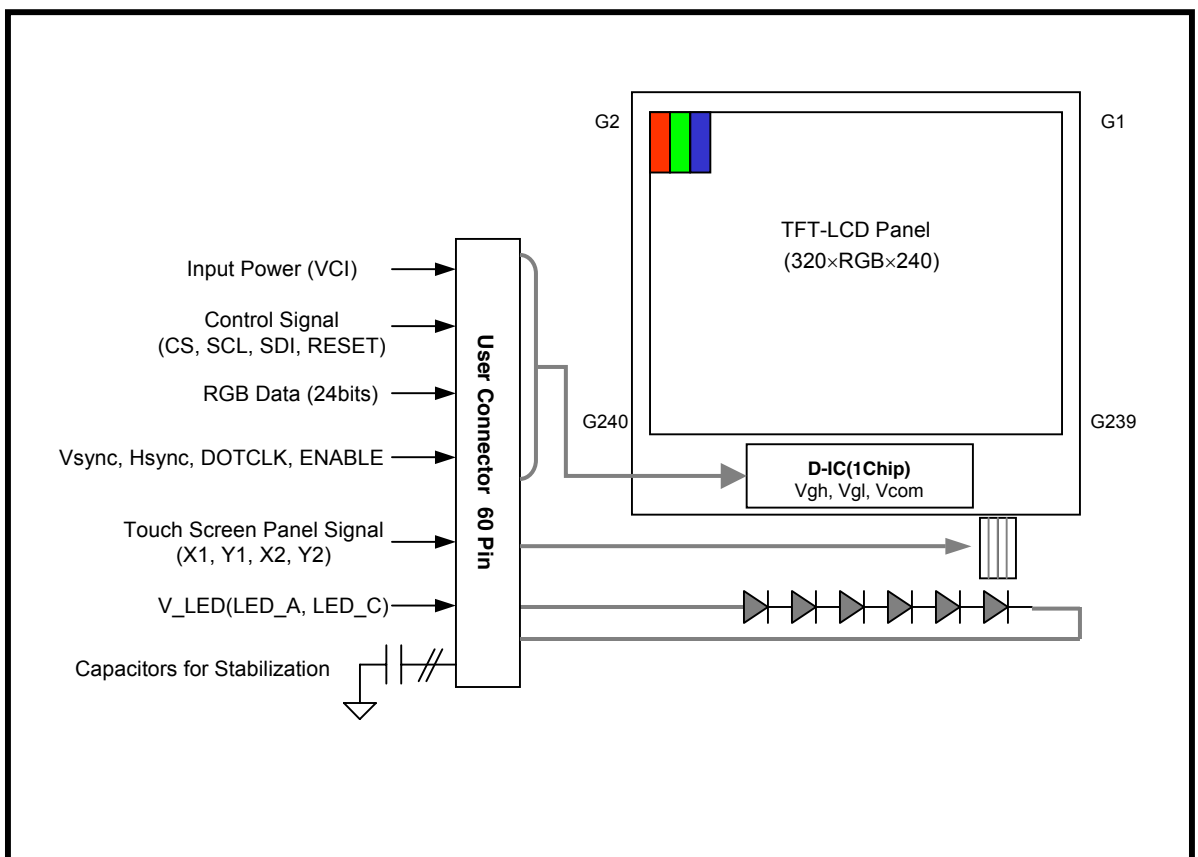

Product Specification

1-3. Features

PARAMETER	SPECIFICATION	REMARK
Active Screen Size	3.5 inches	Diagonal
Outline Dimension	76.9[H] x 63.9[V] x 3.15t[D] (4.25t with Touch Panel)	[mm]
Active Area	70.08[H] x 52.56[V]	[mm]
Number of dots	320[H] x RGB x 240[V]	-
Dot Pitch	0.073 x 0.219	[mm]
Pixel Arrangement	Stripe type	-
Display Mode	TN / Transmissive / Normally White	-
Display Color	Pseudo-16.7M	colors
Viewing Direction	6 o'clock	12 o'clock (good viewing)
Color Filter Array	RGB Vertical Stripe	-
Signal Interface	Digital RGB + SPI Interface	-
Weight	50g	-
Backlight	6 LEDs	Serial Type

Product Specification

2. Interface Connections

This LCD employs one interface connection for the operation of module, LED B/L and TSP.
 The pin configuration for the connector is shown in the table below.

(LCD Connector: FPC(60Pin 0.5mm pitch), Mating Connector: LD09T4-60NB(LS Cable) or equivalent

Pin	Symbol	Description	I/O	Remark
1	LED_C	LED_Cathode	I	
2	LED_A	LED_Anode	I	
3	GND	Ground	I	
4	X1	Touch Panel Position X	I	
5	Y1	Touch Panel Position Y	I	
6	X2	Touch Panel Position X	I	
7	Y2	Touch Panel Position Y	I	
8	GND	Ground	I	
9	NC	No Connect	-	
10	VGL	Gate Low Voltage, Stabilization Cap. + Diode	O	
11	VGH	Gate High Voltage, Stabilization Capacitor	O	
12	NC	No Connect	-	
13	GND	Ground	I	
14	RESET	System Reset	I	
15	CS	Chip Select	I	
16	SCL	Serial Clock Line	I	
17	SDI	Serial Data Input	I	
18	PD0	BB0, Blue Data [LSB]	I	
19	PD1	BB1, Blue Data	I	
20	PD2	BB2, Blue Data	I	
21	PD3	BB3, Blue Data	I	
22	PD4	BB4, Blue Data	I	
23	PD5	BB5, Blue Data	I	
24	PD6	BB6, Blue Data	I	
25	PD7	BB7, Blue Data [MSB]	I	
26	PD8	GG0, Green Data [LSB]	I	
27	PD9	GG1, Green Data	I	
28	PD10	GG2, Green Data	I	
29	PD11	GG3, Green Data	I	
30	PD12	GG4, Green Data	I	
31	PD13	GG5, Green Data	I	
32	PD14	GG6, Green Data	I	
33	PD15	GG7, Green Data [MSB]	I	

Product Specification

Pin	Symbol	Description	I/O	Remark
34	PD16	RR0, Red Data [LSB]	I	
35	PD17	RR1, Red Data	I	
36	PD18	RR2, Red Data	I	
37	PD19	RR3, Red Data	I	
38	PD20	RR4, Red Data	I	
39	PD21	RR5, Red Data	I	
40	PD22	RR6, Red Data	I	
41	PD23	RR7, Red Data [MSB]	I	
42	DOTCLK	Dot clock	I	
43	ENABLE	Data Enable	I	
44	HSYNC	Horizontal Sync Signal	I	
45	VSYNC	Vertical Sync Signal	I	
46	VCI	Power	I	
47	NC	No Connect	-	
48	VCI	Power	I	
49	VCIM	Stabilization Capacitor	O	
50	VLCD63	Stabilization Capacitor	O	
51	NC	No Connect	-	
52	VDD	Stabilization Capacitor	O	
53	VCOML	Stabilization Capacitor	O	
54	VCIX2(J)	Stabilization Cap. + Diode	O	
55	VCOMH	Stabilization Capacitor	O	
56	CN	Stabilization Capacitor (N)	O	
57	CXN	Stabilization Capacitor (N)	O	
58	CXP	Stabilization Capacitor (P)	O	
59	CP	Stabilization Capacitor (P)	O	
60	GND	Ground	I	

Product Specification

2-1. System

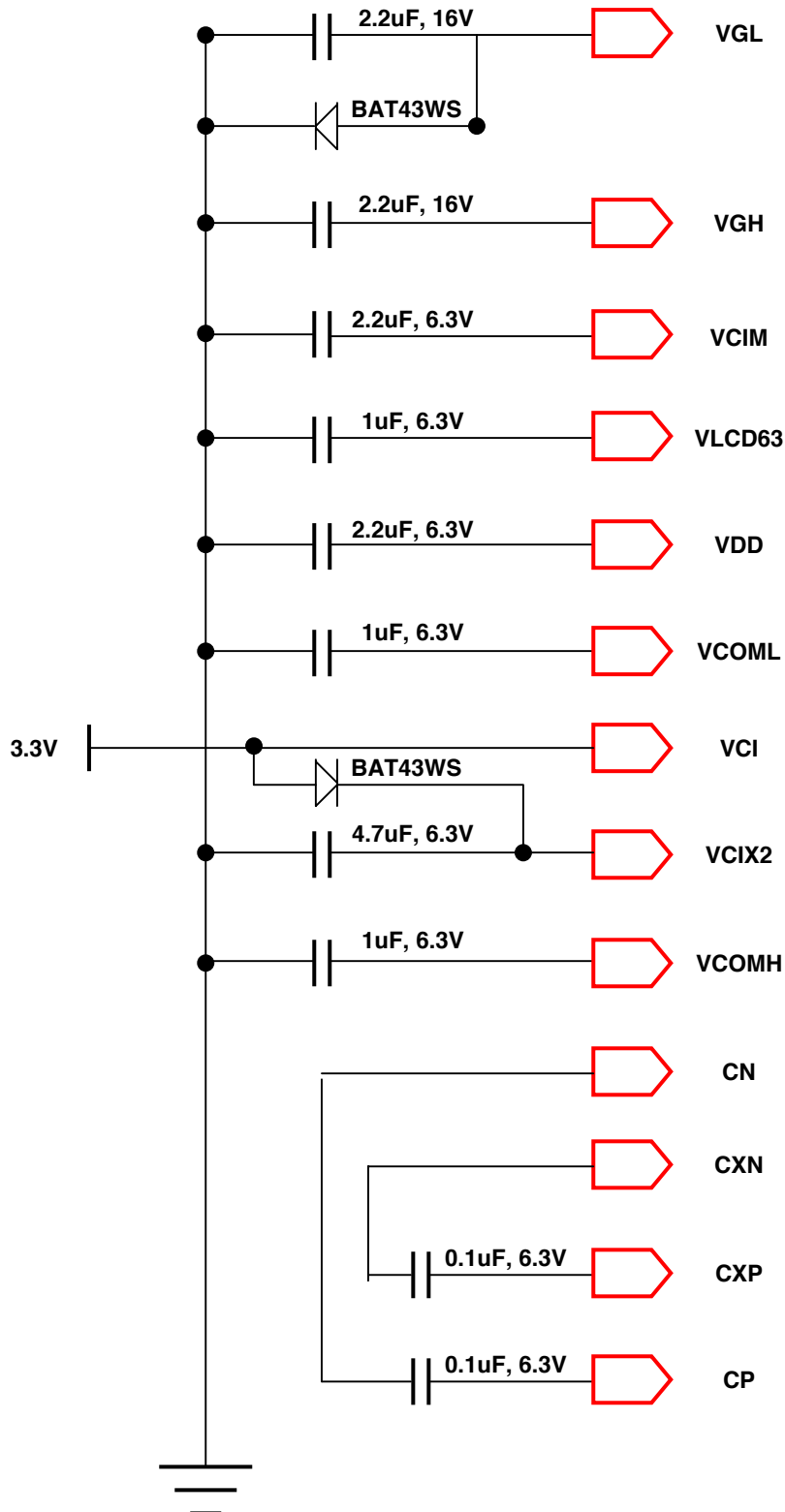

Product Specification

2-2. FPC

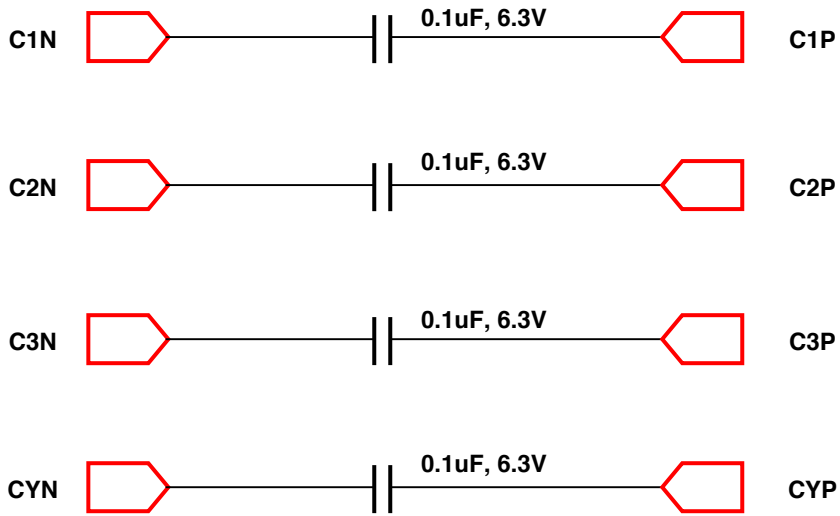

Product Specification

3. Absolute Maximum Ratings

If used the beyond absolute maximum ratings, this device can permanently be damaged.
 It is strongly recommended to use this device at a condition for normal operation.

PARAMETER	SYMBOL	CONDITION	MIN.	MAX.	UNIT	REMARK
Power Supply Voltage	V _{CI}	T _a =25℃	-0.3	5.0	V	-
LED Forward Current	I _f	T _a =25℃	-	25	mA	[Note 3-1]
Operating Temperature	T _{OP}	-	-20	70	℃	[Note 3-2]
Storage Temperature	T _{ST}	-	-30	80	℃	[Note 3-2]
Humidity	H _{OP}	-	5	95	%RH	[Note 3-2]

[Note 3-1] Applies for each LED individually

[Note 3-2] Humidity: 95% RH Max, no condensation > 40 ℃

Product Specification

4. Electrical Characteristics

4-1. TFT LCD Module

$T_a = 25^\circ C$

PARAMETER	SYMBOL	MIN.	TYP.	MAX.	UNIT	REMARK
Power Supply Voltage	V _{CI}	2.5	3.3	3.6	V	
Gate On Voltage	V _{GH}	13	16	19	V	
Gate Off Voltage	V _{GL}	-7	-13	-16	V	
Frame Frequency	f _{FRAME}	-	70		Hz	
Dot Clock	DOTCLK	-	6.5	10	MHz	
Serial Clock	SCL	100	-	-	ns	See. 7-2-2
Input Leakage Current	I _{IL}	-1.0	-	3.0	uA	
Output Leakage Current	I _{OL}	3.0	-	4.5	uA	

4-2. Backlight Unit

$T_a = 25^\circ C$

PARAMETER	SYMBOL	MIN.	TYP.	MAX.	UNIT	REMARK
LED forward Current	I _f	-	20	-	mA	[Note4-1]
Power Consumption	P _{BL}	-	400	-	mW	

[Note4-1] The permissible forward current of LED vary with environmental temperature.

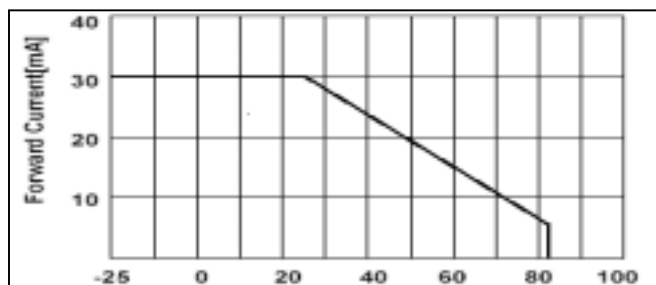

Product Specification

5. Optical Characteristics

5-1. TFT LCD Module

$T_a = 25^\circ C$

PARAMETER	SYMBOL	CONDITION	MIN.	TYP.	MAX.	UNIT	REMARK
Luminance (with Touch Panel)	Y	$I_{BL} = 20mA$	-	300	-	cd/m ²	[Note5-1]
Contrast Ratio	CR	Center Point	-	400	-	-	[Note5-2]
White color Chromaticity	Wx	$I_{BL} = 20mA$		TBD		-	[Note5-1] PR-650
	Wy			TBD		-	
Viewing Angle	Hor.	θ_L	CR > 10	-	65	-	Degrees [Note5-2] [Note5-3] PR-880
		θ_R		-	65	-	
	Ver.	θ_U		-	50	-	
		θ_D		-	60	-	
Response Time	Rising	$T_r + T_f$	$\theta = 0^\circ$	-	25	30	msec [Note5-4] PR-880
	Falling						
Luminance Uniformity	U	$I_{BL} = 20mA$	-	1.20	1.40	-	[Note5-5]

Measurement condition : Refer to the below "Test Equipment Set Up" and next two pages

[Test Equipment Set Up]

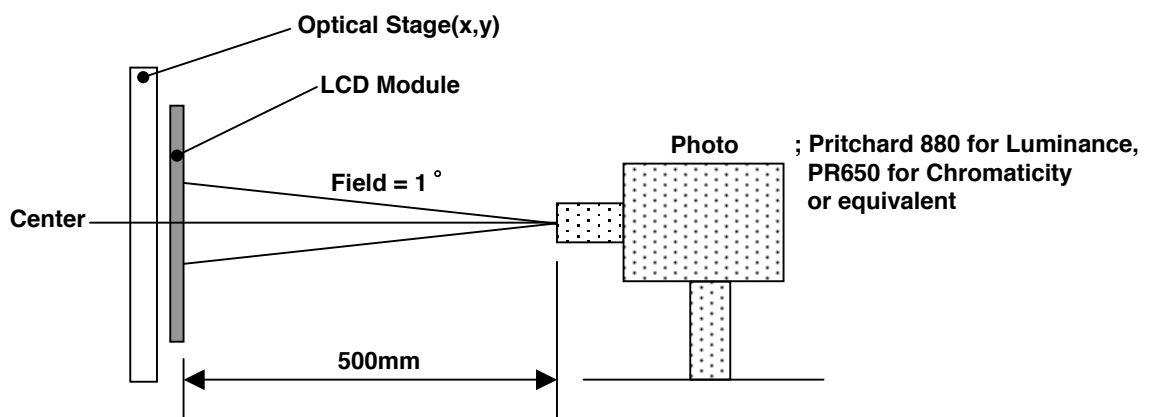

- Measuring Condition ;
 - Measuring surroundings : Dark Room
 - Measuring temperature : $T_a = 25^\circ C$
 - Adjust operating voltage to get optimum contrast at the center of the display.
 - Measured value at the center point of LCD panel after more than 10 minutes while backlight turning on.

Product Specification

[Note 5-1]

Measured on the center area of the panel by PHOTO RESEARCH photometer PR-880&PR650 or Equivalent

[Note 5-2]

Contrast ratio is defined as follows ;

$$\text{Contrast Ratio(CR)} = \frac{\text{Photo detector output with LCD being "white"}}{\text{Photo detector output with LCD being "black"}}$$

[Note 5-3]

Viewing angle range is defined as follows [PR-880];

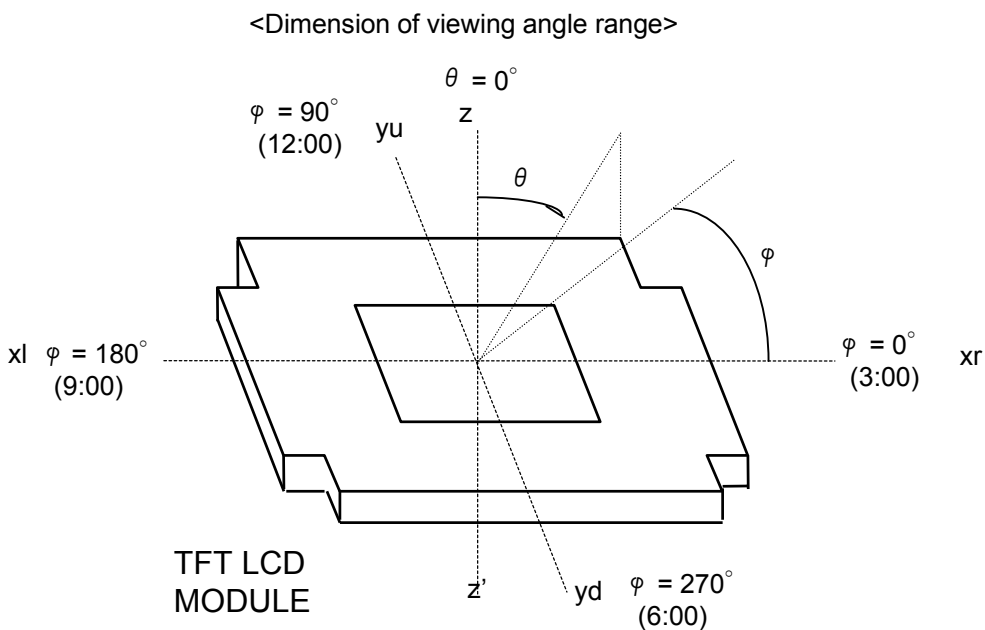

Product Specification

[Note 5-4]

Response time is obtained by measuring the transition time of photo detector output, when input signals are applied so as to make the area "black" to and from "white".

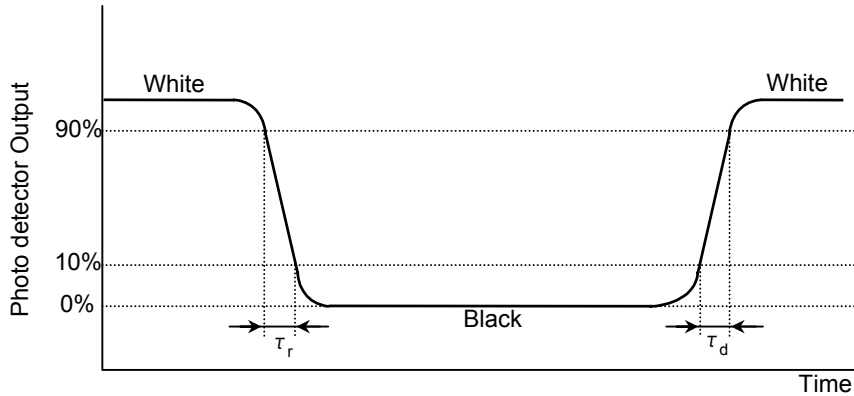

[Note 5-5]

Luminance Uniformity = Maximum of 9points (①~⑨) / Minimum of 9points (①~⑨)
 Luminance Uniformity(%) = Minimum of 9points (①~⑨) / Maximum of 9points (①~⑨) x 100

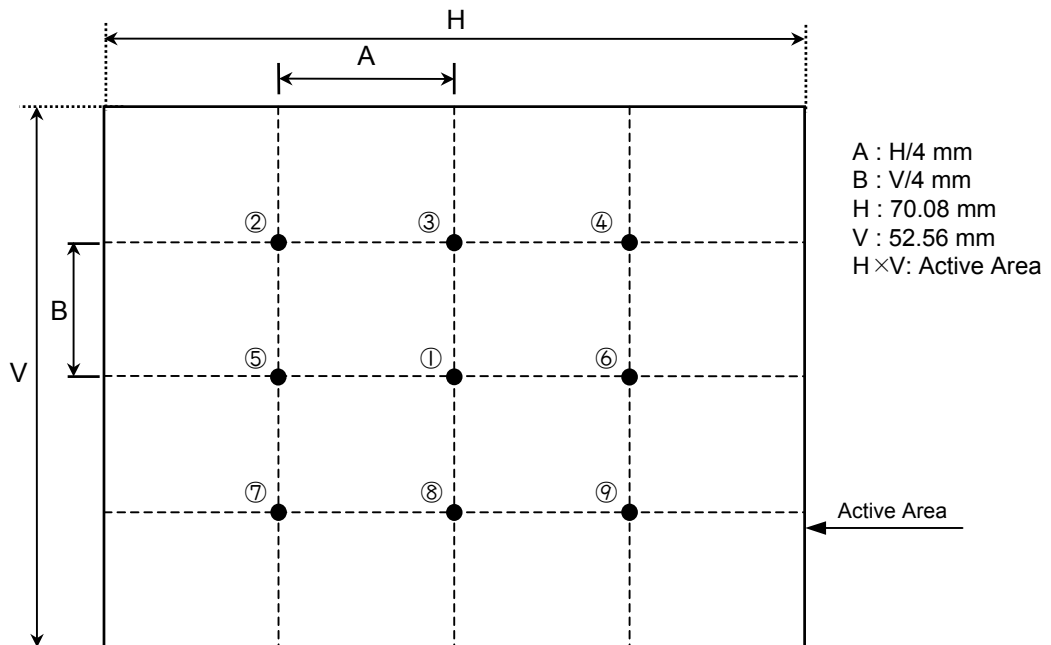

Product Specification

6. Mechanical Characteristics

PARAMETER	SPECIFICATION		UNIT	REMARK
Outline Dimension	Width	76.9	mm	-
	Height	63.9	mm	
	Depth	3.15 (without TSP) 4.25 (with TSP)	mm	
Bezel Area	Width	72.48	mm	
	Height	55.26	mm	
Weight	50 (Typ.)		g	
Surface Treatment	Clear Hard Coating(3H) Treatment			

Product Specification

7. Operation Specifications

7-1. RGB Data Interface

7-1-1. RGB Data Interface Timing Characteristics

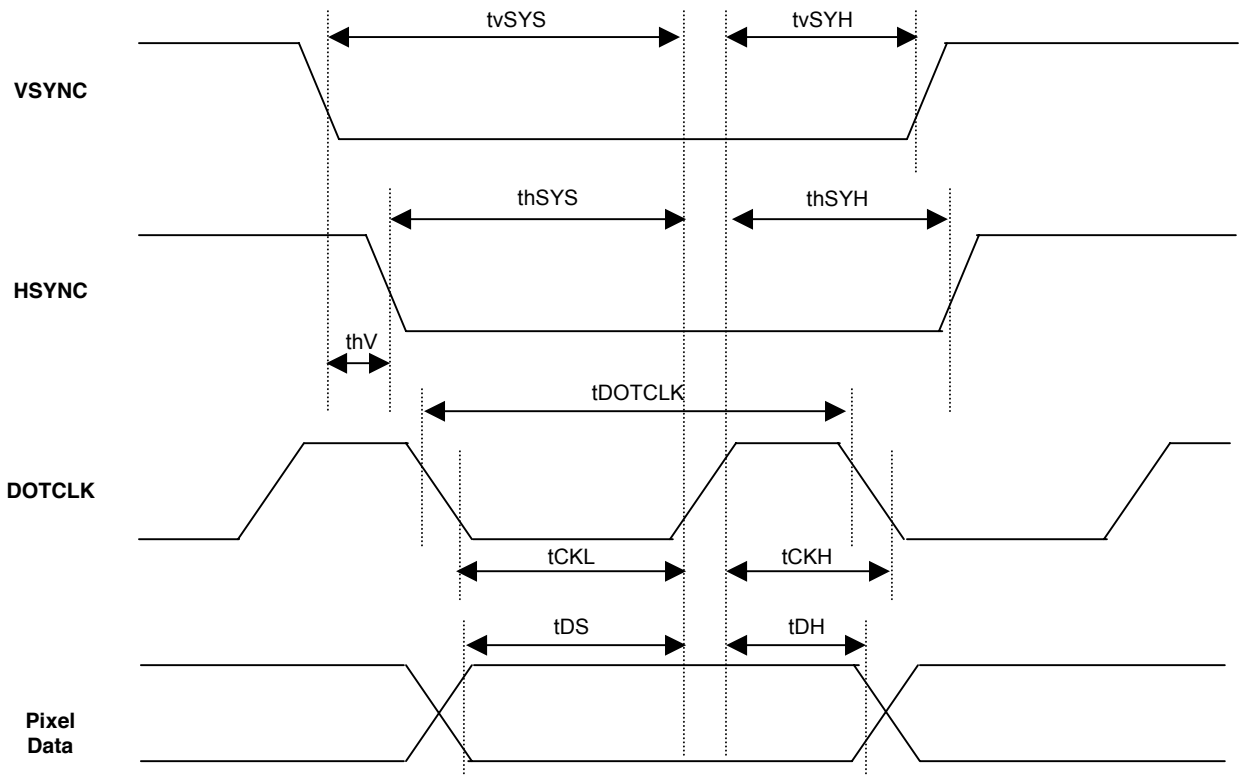

PARAMETER	SYMBOL	24bit Interface		8 bit Interface		Unit
		Min.	Max.	Min.	Max.	
DOTCLK Period	tDOTCLK	100	-	33.3	-	ns
DOTCLK Low Period	tCKL	50	-	15	-	ns
DOTCLK High Period	tCKH	50	-	15	-	ns
DOTCLK Frequency	tDOTCLK	10	-	30	-	ns
Vertical Sync Setup Time	tvSYS	20	-	10	-	ns
Vertical Sync Hold Time	tvSYH	20	-	10	-	ns
Horizontal Sync Setup Time	thSYS	20	-	10	-	ns
Horizontal Sync Hold Time	thSYH	20	-	10	-	ns
Data Setup Time	tDS	12	-	10	-	ns
Data Hold Time	tDH	12	-	10	-	ns

[Note] External clock source must be provided to LCM.
The LCM will not operate if absent of the clocking signal.

Product Specification

7-1-2. Data Format for 24 bit RGB Data Interface

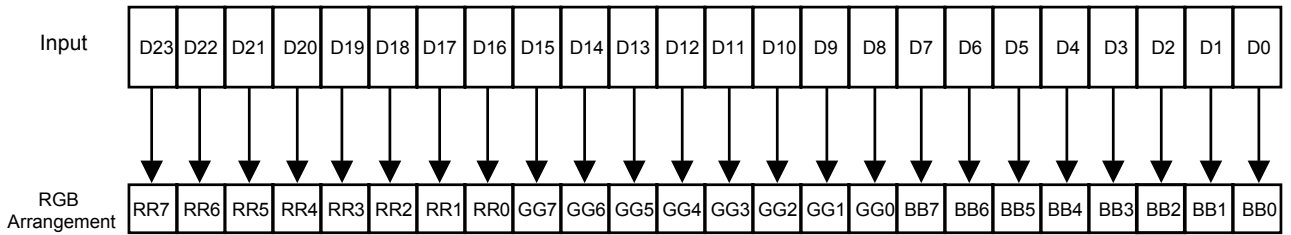

7-1-3. Data Format for 18 bit RGB Data Interface

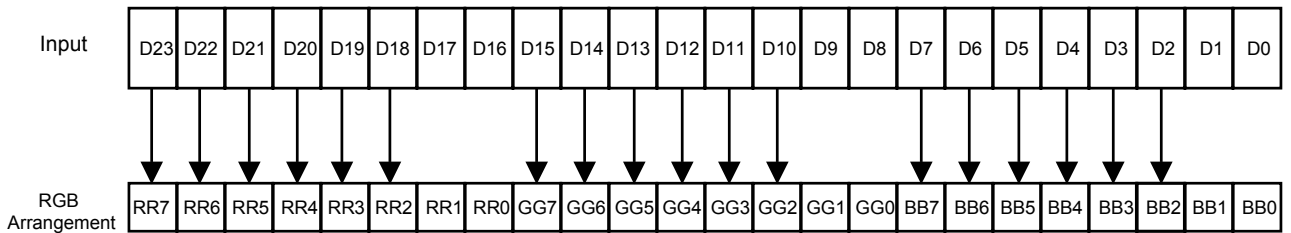

[Note] LSB 2bits are connected to VSS or floating.

7-1-4. Data Format for 8 bit RGB Data Interface

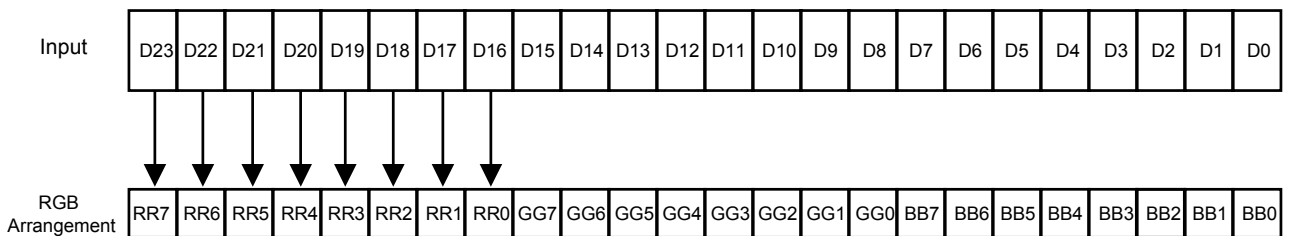

[Note] For 8 bit interface, only RR[7:0] are used.
For unused pins, please connect to GND or floating.

Product Specification

7-1-3. 24 Bit RGB Interface Timing

7-1-3-1. Sync Mode

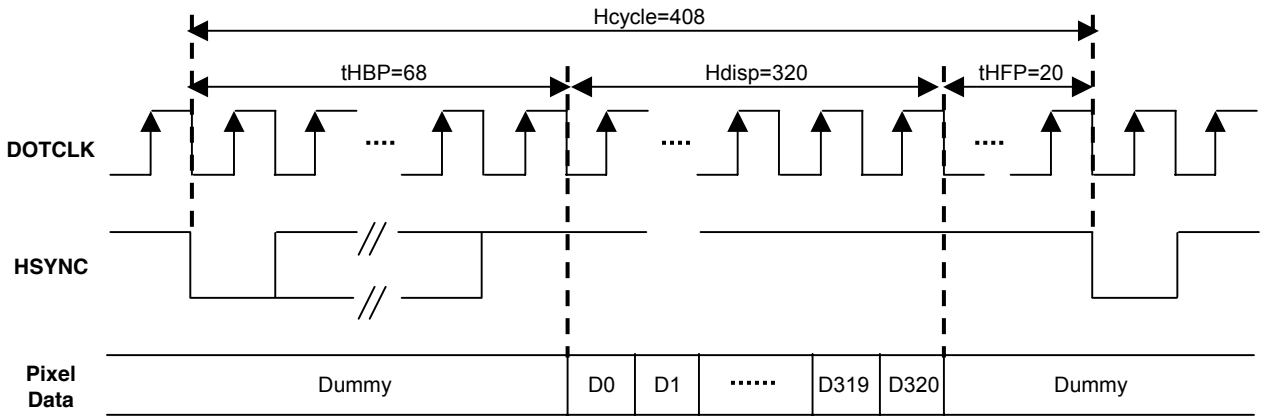

a) Horizontal Data Transaction Timing

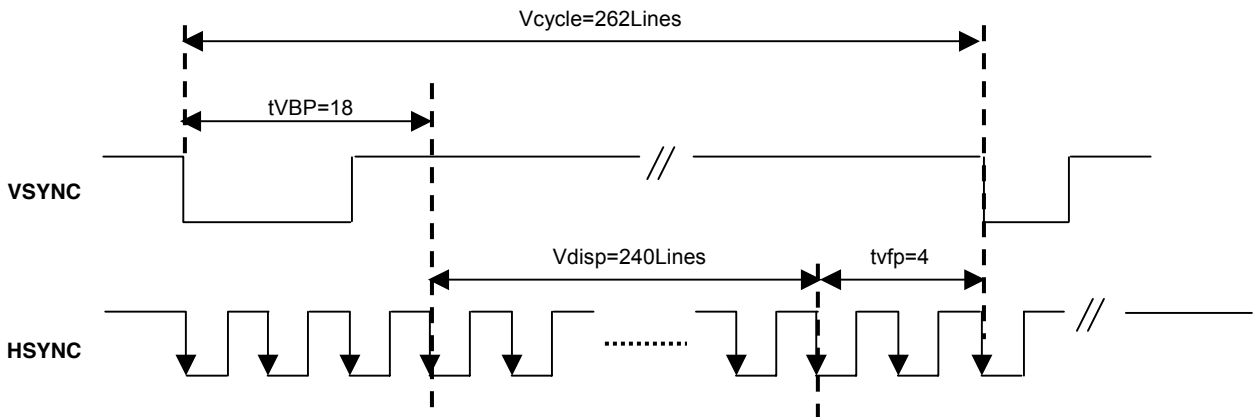

b) Vertical Data Transaction Timing

PARAMETER	SYMBOL	Typ.		Unit
		24bit	8bit	
DOTCLK Frequency	f _{DOTCLK}	6.5	19.5	MHz
DOTCLK Period	t _{DOTCLK}	154	51.3	ns
Horizontal Frequency(Line)	f _H	14.9	14.9	kHz
Vertical Frequency(Refresh)	f _V	60	60	Hz
Horizontal Back porch	t _{HBP}	68	204	t _{DOTCLK}
Horizontal Front porch	t _{HFP}	20	60	t _{DOTCLK}
Vertical Back porch	t _{VBP}	18	18	Lines
Vertical Front porch	t _{VFP}	4	4	Lines
Vertical Display Area	t _{DISP}	240	240	Lines

[Note] The rising edge of DOTCLK is used to fetch display data PD bus.
The Delay amount of the source output must be larger than the Hsync Low Pulse Width.

Product Specification

7-1-3. 24 Bit RGB Interface Timing

7-1-3-2. DE Mode

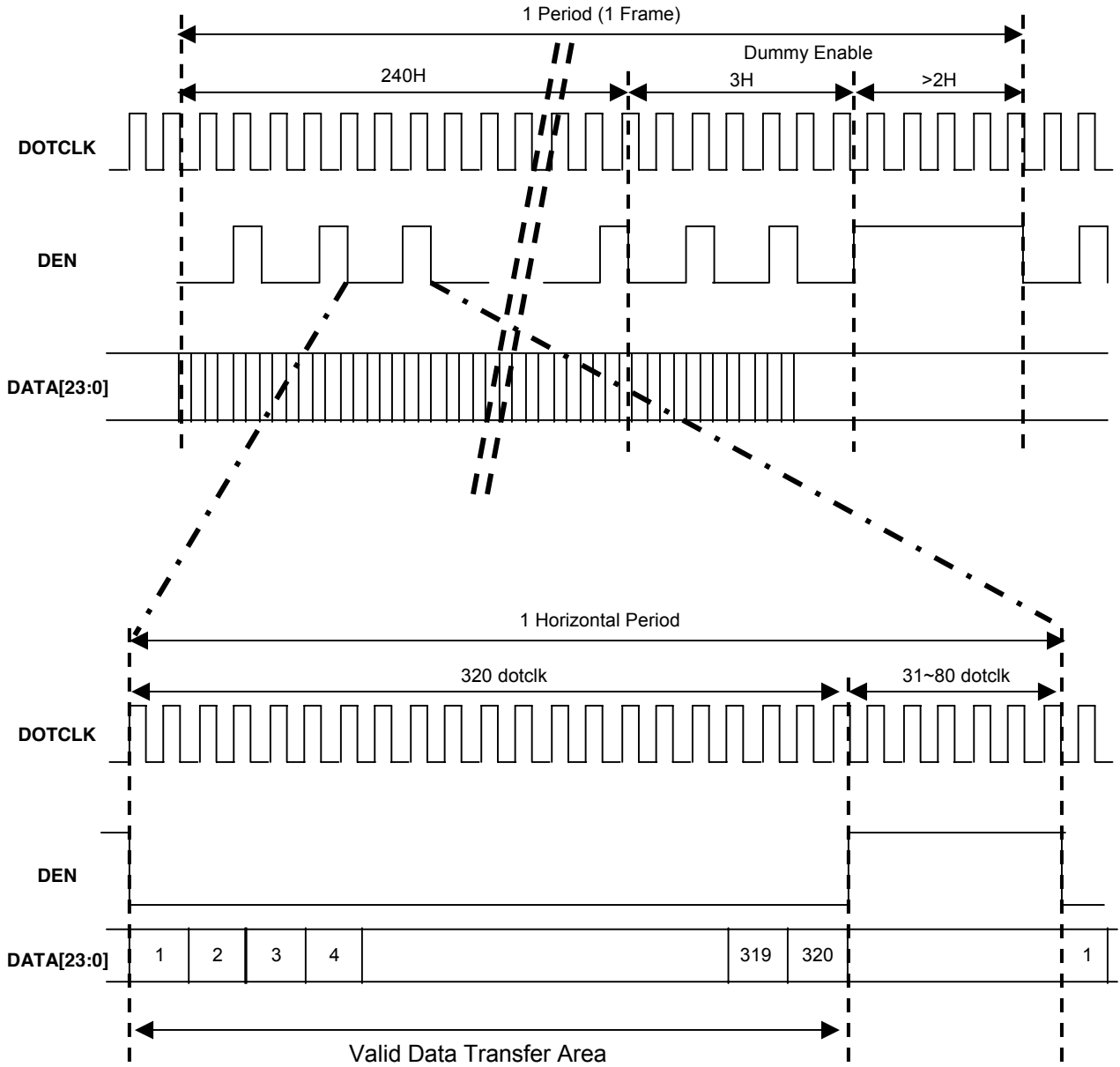

Product Specification

7-2. Serial Peripheral Interface

7-2-1. Serial Peripheral Interface Timing

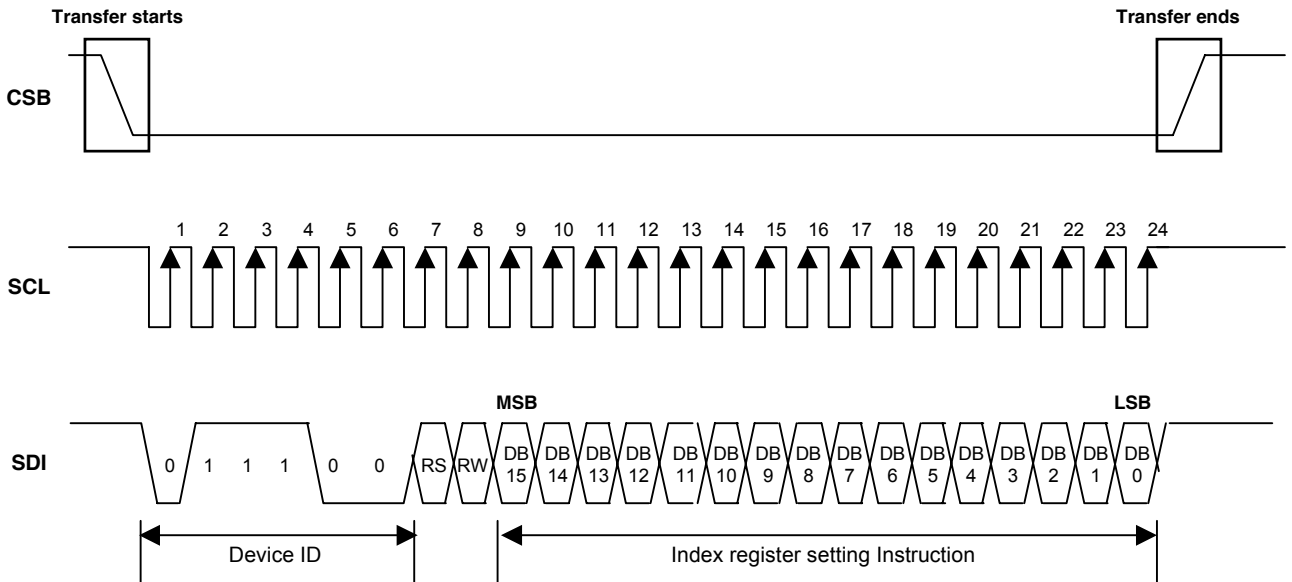

[Note] RS="0" [Index], RS="1" [Instruction]

Product Specification

7-2-2. Clock Synchronized Serial Mode Characteristics

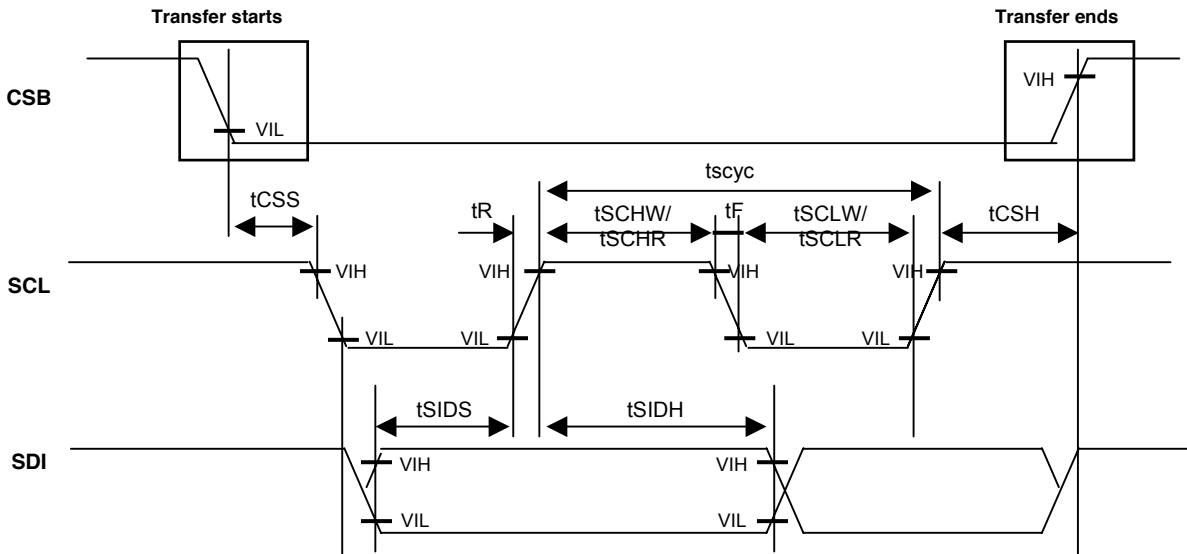

PARAMETER	SYMBOL	MIN.	MAX.	UNIT
Serial Clock Cycle Time	tscyc	100	-	ns
Serial Clock Rise/Fall Time	tR,tF	-	2	
Pulse Width High For Write	tSCHW	30	-	
Pulse Width High For Read	tSCHR	50	-	
Pulse Width Low For Write	tSCLW	30	-	
Pulse Width Low For Read	tSCLR	50	-	
Chip Select Setup Time	tCSS	20	-	
Chip Select Hold Time	tCSH	50	-	
Serial Input Data Setup Time	tSIDS	30	-	
Serial Input Data Hold Time	tSIDH	30	-	

Product Specification

8. Power On/Off Sequence

8-1. Power On Sequence

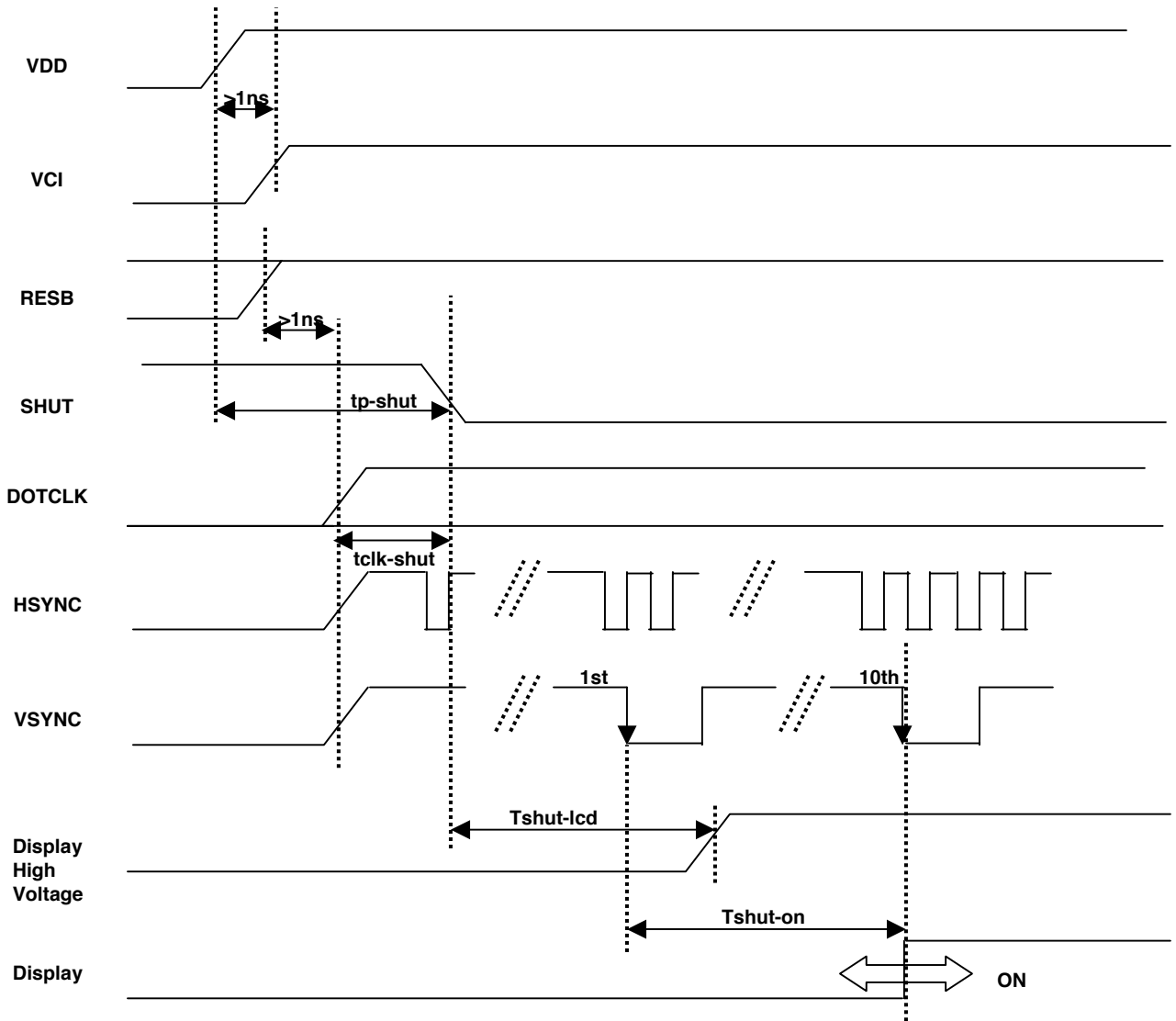

Characteristics	SYMBOL	MIN.	Typ.	MAX.	Units
VDD on to falling edge of SHUT	tp-shut	1	-	-	us
DOTCLK	tclk-shut	1	-	-	clk
Falling edge of SHUT to LCD power on	tshut-lcd	-	-	128	ms
Falling edge of SHUT to display start	tshut-on	-	-	10	frame
-1 line : 408 clk		-	166	-	ms
- 1 frame : 262 line -DOTCLK = 6.5MHz		-	-	-	-

[Note] It is necessary to input DOTCLK before the falling edge of SHUT.
Display starts at 10th falling edge of VSYNC after the falling edge of SHUT.

Product Specification

8-2. Initial Code

[TBD]

Product Specification

8-3. Power Off Sequence

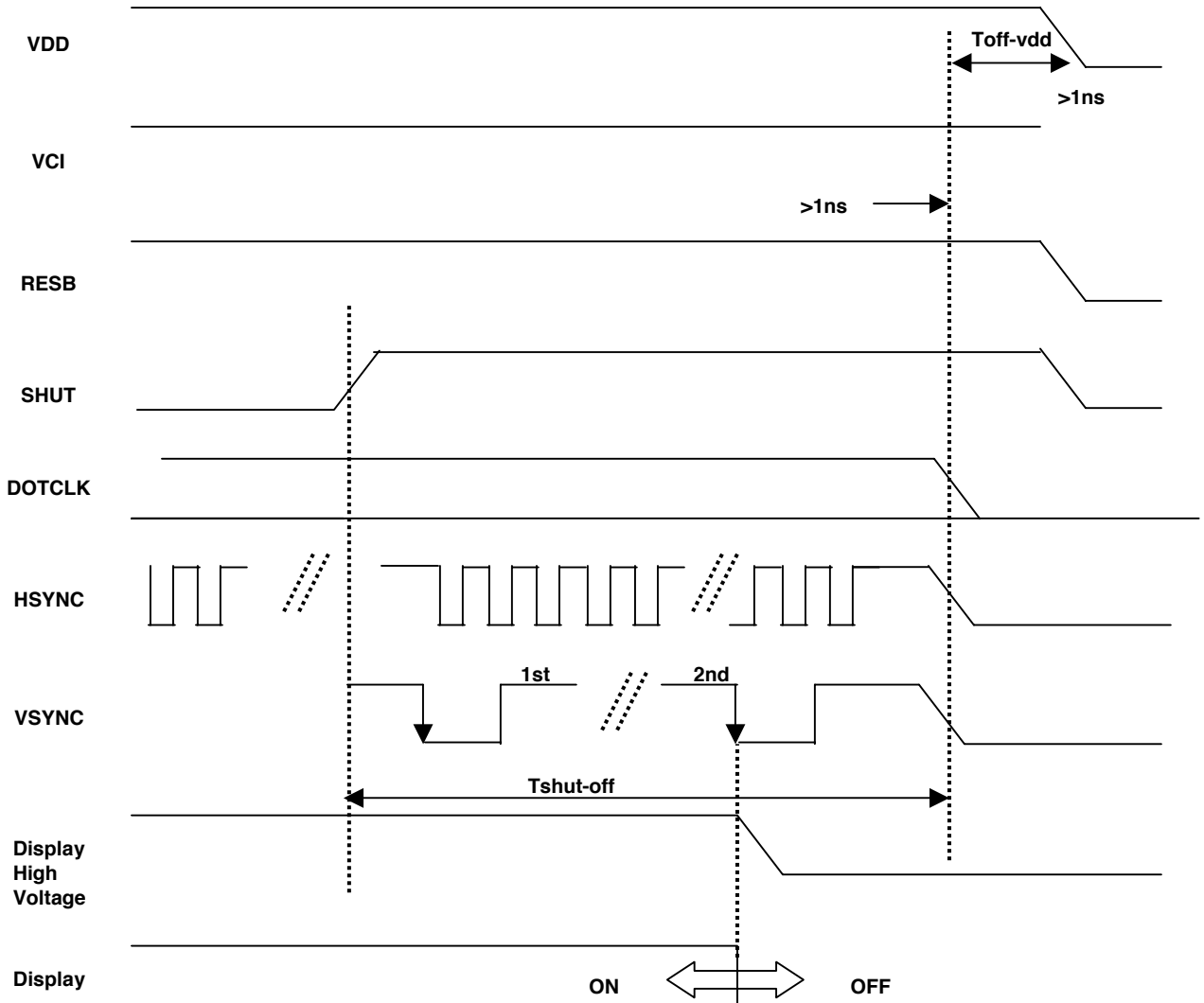

Characteristics	SYMBOL	MIN.	Typ.	MAX.	Units
Rising edge of SHUT to display off	tshut-off	2	-	-	frame
- 1 line : 408 clk -1 frame : 262 line - DOTCLK =6.5MHz		33.4	-	-	ms
Input-signal-off to VDD off	tshut-vdd	1	-	-	us

[Note] DOTCLK must be maintained at least 2 frames after the rising edge of SHUT.
 Display become off at the 2nd falling edge of VSYNC after the falling edge of SHUT.
 If RESET signal is necessary for power down, provide it after the 2-frame-cycle of the SHUT period.

Product Specification

9. Reliability Test

NO	TEST ITEMS	CONDITION	REMARK
1	High Temperature Storage Test	Ta = 80℃ 240h	-
2	Low Temperature Storage Test	Ta = -30℃ 240h	-
3	High Temperature Operation Test	Ta = 70℃ 240h	-
4	Low Temperature Operation Test	Ta = -20℃ 240h	-
5	High Temperature and High Humidity Operation Test	Ta = 60℃ 90%RH 240h	-
6	Shock Test (operating)	Operation, 180G, 2msec, Half Sine ±X, ±Y, ±Z Per 1time	-
7	Vibration Test (operating)	Random Operation 10~200~10Hz, 0.37Oct/min, 2.0G X/Y/Z direction, Per 1Hour	-
8	Thermal Shock Test	-30℃ (0.5h) ~ 80℃ (0.5h) / 100cycle	-

[Note]

T_a = Ambient Temperature

In the standard condition, there shall be no practical problems that may affect the display function.

Result Evaluation Criteria

TFT- LCD Module should be at room temperature for 2 hours when the display quality test is over. There should be no particular change which might affect the practical display function and the display quality test should be conducted under normal operating condition.

Product Specification

10. Outline Dimension

10-1. Front View

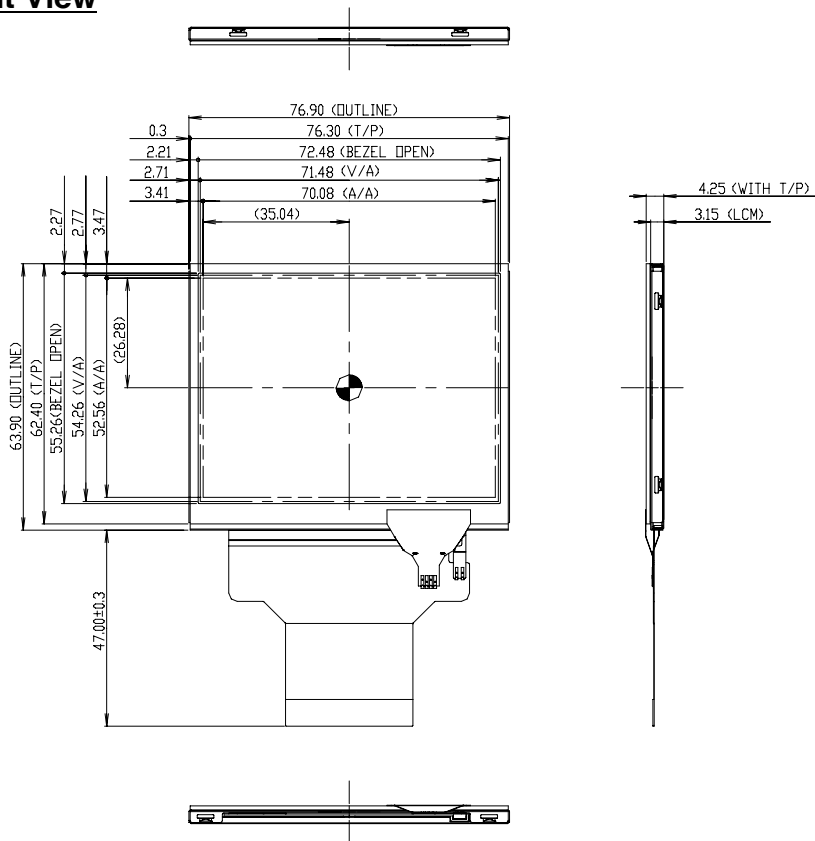

10-2. Rear View

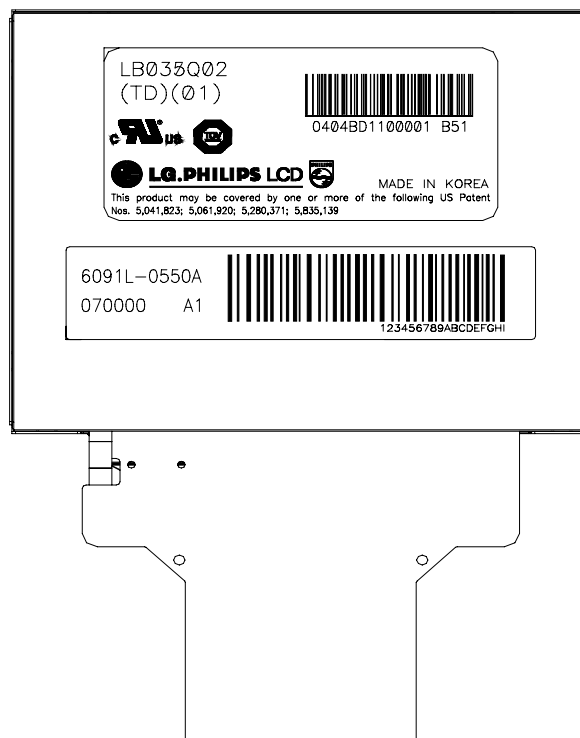

Product Specification

10-3. FPC (Front View)

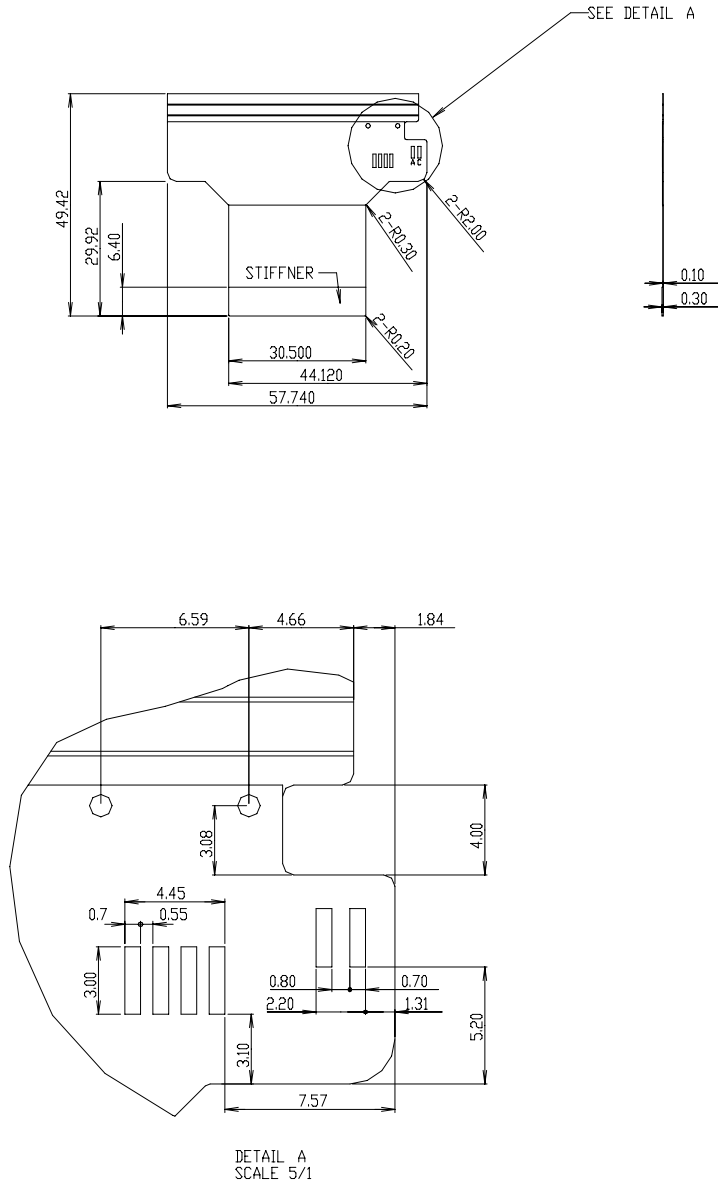

Product Specification

11. Packing

11-1. Designation of Lot Mark

a) Lot Mark

A	B	C	D	E	F	G	H	I	J	K	L	M
---	---	---	---	---	---	---	---	---	---	---	---	---

A,B,C : SIZE(INCH)
E : MONTH

D : YEAR
F ~ M : SERIAL NO.

Note

1. YEAR

Year	2001	2002	2003	2004	2005	2006	2007	2008	2009	2010
Mark	1	2	3	4	5	6	7	8	9	0

2. MONTH

Month	Jan	Feb	Mar	Apr	May	Jun	Jul	Aug	Sep	Oct	Nov	Dec
Mark	1	2	3	4	5	6	7	8	9	A	B	C

b) Location of Lot Mark

Serial No. is printed on the label. The label is attached to the backside of the LCD module.
This is subject to change without prior notice.

Product Specification

11-2. Packing Form

- a) Package quantity in one box : 180 pcs
- b) Box Size : 475mm × 348mm × 210mm
- c) 1Box = tray 20 + 1 tray(dummy , top) = 21 tray

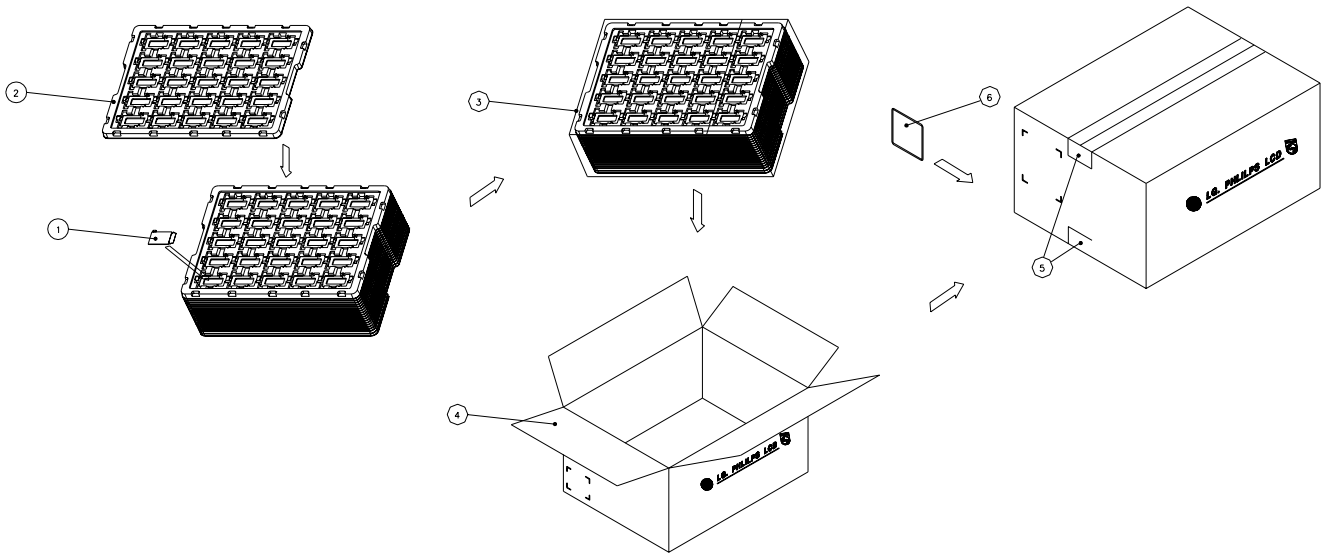

NO.	Description	Material
1	Module	
2	Packing, Tray	PET(0.8t)
3	Bag	PE 560x 830
4	Box	SWR4 378x324x112
5	Tape	OPP 70MMx300m
6	Label	Art Paper 100x100

Product Specification

12. Marking & Others

12-1. Designation of Lot Mark

12-1-1 Lot Mark

A	B	C	D	E	F	G	H	I	J	K	L	M
---	---	---	---	---	---	---	---	---	---	---	---	---

A,B,C : SIZE (INCH)
E : MONTH
G : ASSEMBLY CODE

D : YEAR
F : FACTORY CODE
H ~ M : SERIAL NO.

[Note]

1. YEAR

Year	2001	2002	2003	2004	2005	2006	2007	2008	2009	2010
Mark	1	2	3	4	5	6	7	8	9	0

2. MONTH

Month	Jan	Feb	Mar	Apr	May	Jun	Jul	Aug	Sep	Oct	Nov	Dec
Mark	1	2	3	4	5	6	7	8	9	A	B	C

3. FACTORY CODE

Factory Code	LPL Gumi	LPL Nanjing	HEESUNG
Mark	K	C	D

4. SERIAL NO.

Mark	100001~199999, 200001~299999, 300001~399999,, A00001~A99999,, Z00001~Z99999
------	---

12-1-2 Location of Lot Mark

Serial No. is printed on the label. The label is attached to the backside of the LCD module.
This is subject to change without prior notice.

Product Specification

13. Precautions

Please pay attention to the following when you use this TFT LCD module.

13-1. Mounting Precautions

- <1> You may mount a module using four corner sides.
- <2> You should consider the mounting structure so that uneven force(ex. Twisted stress) is not applied to the module.
And the case on which a module is mounted should have sufficient strength so that external force is not transmitted directly to the module.
- <3> Please attach a transparent protective plate to the surface in order to protect the polarizer.
Transparent protective plate should have sufficient strength in order to resist external force.
- <4> You should adopt radiation structure to satisfy the temperature specification.
- <5> Acetic acid type and chlorine type materials for the cover case are not desirable because the former generates corrosive gas of attacking the polarizer at high temperature and the latter causes circuit break by electro-chemical reaction.
- <6> Do not touch, push or rub the exposed polarizers with glass, tweezers or anything harder than HB pencil lead. And please do not rub with dust clothes with chemical treatment.
Do not touch the surface of polarizer for bare hand or greasy cloth.(Some cosmetics deteriorate the polarizer.)
- <7> When the surface becomes dusty, please wipe gently with absorbent cotton or other soft materials like chamois soaks with petroleum benzine. Normal-hexane is recommended for cleaning the adhesives used to attach front / rear polarizers. Do not use acetone and toluene because they cause chemical damage to the polarizer.
- <7> Wipe off saliva or water drops as soon as possible. Their long time contact with polarizer causes deformations and color fading.
- <8> Do not open the case because inside circuits do not have sufficient strength.
- <9> The metal case of a module should be contacted to electrical ground of your system.

13-2. Operating Precautions

- <1> The spike noise causes the disoperation of circuits. It should be lower than following voltage
 $V = \pm 200\text{mV}$ (Over and under shoot voltage)
- <2> Response time depends on the temperature.(In lower temperature, it becomes longer.)
- <3> Brightness depends on the temperature. (In lower temperature, it becomes lower.)
And in lower temperature, response time(required time that brightness is stable after turned on) becomes longer.
- <4> Be careful for condensation at sudden temperature change. Condensation makes damage to polarizer or electrical contacted parts. And after fading condensation, smear or spot will occur.
- <5> When fixed patterns are displayed for a long time, remnant image is likely to occur.
- <6> Module has high frequency circuits. Sufficient suppression to the electromagnetic interference shall be done by system manufacturers. Grounding and shielding methods may be important to minimized the interference.

Product Specification

13-3. Electrostatic Discharge Control

Since a module is composed of electronic circuits, it is not strong to electrostatic discharge. Make certain that treatment persons are connected to ground through wrist band etc. And don't touch interface pin directly.

13-4. Precautions For Strong Light Exposure

Strong light exposure causes degradation of polarizer and color filter.

13-5. Storage

When storing modules as spares for a long time, the following precautions are necessary.

- <1> Store them in a dark place. Do not expose the module to sunlight or fluorescent light. Keep the temperature between 5°C and 35°C at normal humidity.
- <2> The polarizer surface should not come in contact with any other object.
- <3> The warranty for storage of the color TFT-LCD module shall be in compliance with the Incoming Inspection standard.

13-6. Handling Precautions For Protection Film

- <1> When the protection film is peeled off, static electricity is generated between the film and polarizer. This should be peeled off slowly and carefully by people who are electrically grounded and with well ion-blown equipment or in such a condition, etc.
- <2> The protection film is attached to the polarizer with a small amount of glue. If some stress is applied to rub the protection film against the polarizer during the time you peel off the film, the glue is apt to remain on the polarizer.
Please carefully peel off the protection film without rubbing it against the polarizer.
- <3> When the module with protection film attached is stored for a long time, sometimes there remains a very small amount of glue still on the polarizer after the protection film is peeled off.
- <4> You can remove the glue easily. When the glue remains on the polarizer surface or its vestige is recognized, please wipe them off with absorbent cotton waste or other soft material like chamois soaked with normal-hexane.

14. Production Center

- <1> Panel : LG Philips LCD (Gumi, Korea)
- <2> Module Assembly : LPL NJ (Nanjing, China)
- <3> Shipping Place : LG Philips LCD(Gumi, Korea)