

Product Specification

SPECIFICATION FOR APPROVAL

- () Preliminary Specification
(●) Final Specification

Title	6.5" W (400 X RGB X 234) TFT- LCD
--------------	------------------------------------------

BUYER	
MODEL	

SUPPLIER	LG.Philips LCD CO.,Ltd.
MODEL	LB065W01
SUFFIX	* B11B

* The model included T-con separately

SIGNATURE	DATE
/	_____
/	_____
/	_____

APPROVED BY	DATE
C. S. KYOUNG/ G. Manager	_____
REVIEWED BY	
J.D. KIM / Manager	_____
PREPARED BY	
K.J. LEE / Engineer	_____

**Product Engineering Dept.
LG. Philips LCD Co., Ltd**

Product Specification**Contents**

NO.	ITEM	PAGE
1	Record of Revisions	3
2	Summary	4
3	Features	4
4	General Specification	4
5	Interface (Input Terminal)	5
6	Absolute Maximum Ratings	6
7	Electrical Characteristics	8
8	Electro-optical Characteristics	14
9	Mechanical Characteristics	17
10	Reliability Test	19
11	International Standards	20
12	Packing	21
13	Precautions	22

Product Specification

1. Summary

This module utilizes amorphous silicon thin film transistors and a 16:9 aspect ratio. A 6.5" active matrix liquid crystal display allows full color to be displayed.

The applications are Portable DVD, Multimedia applications and others AV system.

2. Features

- Utilizes a panel with a 16:9 aspect ratio, which makes the module suitable for use in wide-screen systems.
- The 6.5" screen produces a high resolution image that is composed of 93,600 pixel elements in a stripe arrangement.
- Wide viewing angle technology is employed.
[The most suitable viewing direction is in the 6 o'clock direction.]
- By adopting an active matrix drive, a picture with high contrast is realized.
- A thin, light and compact module is accomplished through the use of COG mounting technology.
- By adopting a high aperture panel, high transmittance color filter and high transmission polarizing plates, transmittance ratio is realized.
- This module is compatible with the T-con(Timing controller) developed by LG.Philips LCD.
[**T-con Model Name : FORT_REV(HS503022)** , **Part Number :0IHYL-0047A**]
For a application including the T-con, please refer to the T-con datasheet with this specification sheet.

3. General Specification

CHARACTERISTIC ITEM	SPECIFICATION
Display Technology	a-Si TFT active matrix
Display Mode	TN Type Full Color / Transmitting Type / Normally White
Screen Size (Diagonal)	6.5" (16.39cm)
Outline Dimension (W x H x D)	157.2[mm] X 89.7[mm] X 8.0 [mm] TYP.
Active Area	143.4[mm] X 79.3 [mm] TYP.
Number Of dots	400(W) X 3(RGB) X 234(H)
Dot Pitch	0.1195(W) [mm] X 0.3385(H) [mm]
Color Filter Array	RGB vertical stripes
Weight	165g (TYP.)
Backlight	CCFL with 3 wave-length spectrum (U Type)
Surface Treatment	Anti-Glare Treatment

Product Specification
4. Interface (Input terminal)

1> TFT-LCD panel driving part

Pin No.	SYMBOL	i/o	FUNCTION	REMARK
1	VGH	i	Power supply for gate driver(High level)	
2	OPEN	-	Open	
3	CS	i	CST electrode driving signal	
4	MODE2	i	Control signal for gate driver	
5	MODE1	i	Control signal for gate driver	
6	Up/Down	i	Control signal for gate driver	
7	GSP	i	Start signal for gate driver	
8	GSC	i	Clock signal for gate driver	
9	VCC	i	Power supply for gate driver Logic(Low level)	
10	OPEN	-		
11	OPEN	-		
12	VSS	i	Power supply for gate driver(Low level)	
13	OPEN	-		
14	OPEN	-		
15	VGL	i	Gate off voltage	
16	VCOM	i	Common electrode driving signal	
17	GND	i	GND	
18	SSC	i	Clock signal for source driver	
19	SSP_L	i/o	Start signal for source driver	
20	SOE	i	Control signal for source driver	
21	TST	i	Hi=VSH	
22	Left/Right	i	Control signal for source driver	
23	SSP_R	i/o	Start signal for source driver	
24	SAM	i	Control signal for source driver	
25	VA(B)	i	Color video signal Blue	
26	VB(G)	i	Color video signal Green	
27	VC(R)	i	Color video signal Red	
28	GND	i	GND	
29	VSHA1	i	Power supply for source driver(High level)	
30	VSHA2	i	Power supply for source driver(High level)	
31	VSHL2	i	Power supply for source driver(High level)	
32	VSHL1	i	Power supply for source driver(High level)	

* Input connector for the operation of LCD module : SFV32R-1ST(FCI) or GF053-32S-LSS(LGC) or equivalent

Product Specification
5. Absolute Maximum Ratings

PARAMETER		SYMBOL	CONDITION	MIN.	MAX.	UNIT	REMARK
Source Driver Voltage		VSH	T _a =25℃	-0.3	6.0	V	
Digital Input Signals		VID	T _a =25℃	-0.3	VSH+0.3	V	[Note 5-1]
Analog Input Signals		VIA	T _a =25℃	-0.3	VSH+0.3	V	[Note 5-2]
Gate Driver Voltage	TFT	Hi	VGH	T _a =25℃	-0.3	33.0	V
		Lo	VGL	T _a =25℃	VGH-33.0	VGH+0.3	V
	LOGIC	Hi	VCC	T _a =25℃	VSS-0.3	VSS+7.0	V
		Lo	VSS	T _a =25℃	VGH-33.0	VGH+0.3	V
Storage Temperature		T _{ST}	-	-40	85	℃	[Note 5-3,4]
Operating Temperature (Panel Surface)		T _P	-	-30	85	℃	[Note 5-3,4,5,6]
Operating Temperature (Ambient Temperature)		T _a	-	-30	65	℃	

[Note 5-1] MODE2,MODE1,Up/Down,GSP,GSC,SSC,SSP_L,SSP_R,SOE,Left/Right,SAM

[Note 5-2] VA(B), VB(G), VC(R)

[Note 5-3] This rating applies to all parts of the module and should not be exceeded.

[Note 5-4] Maximum wet-bulb temperature is 58℃. Condensation of dew must be avoided as electrical current leaks will occur, causing a degradation of performance specifications.

[Note 5-5] The operating temperature only guarantees operation of the circuit. The contrast, response speed, and the other specification related to electro-optical display quality is determined at the room temperature, T_a ≒ 25℃.

[Note 5-6] Ambient Temperature when the backlight is lit(reference value).

Product Specification

2> Backlight fluorescent tube driving part

Terminal	No.	SYMBOL	FUNCTION	REMARK
CN1	1	LV	Power Supply For Lamp [Low Voltage Side]	[Note 4-1]
	2	NC	No Connection	
	3	HV	Power Supply For Lamp [High Voltage Side]	[Note 4-2]

The backlight interface connector is a model **BHR-03VS-1**, manufactured by JST or a compatible model manufactured by AMP. The matching connector part number is **SM02(8.0)B-BHS-1-TB** or equivalent.

[Note 4-1] The wire color of low voltage side is white. Connect the low voltage side of the DC/AC inverter used to drive the fluorescent tube to GND of the inverter circuit.

[Note 4-2] The wire color of high voltage side is pink.

Product Specification

6. Electrical Characteristics

1> Recommended Operating Conditions

◆ TFT-LCD Panel Driving Section

$T_a=25^{\circ}\text{C}$

PARAMETER		SYMBOL	MIN.	TYP.	MAX.	UNIT	REMARK		
Source driver voltage		VSH	4.5	5.0	5.5	V	[Note 6-1]		
Gate driver voltage	TFT	Hi	VGH	12.5	13.0	13.5	V	(Note 6- 1,2)	
		Lo	AC	VGLAC	4.0	5.0	6.0		Vp-p
			DC	VGLDC	-9.5	-10.0	-10.5		V
	Logic	Hi	VCC	-10.4	-10.9	-11.4	V		
		Lo	VSS	-15.5	-16.0	-16.5	V		
Analog input voltage		AC	VIAC		-	±2.5	V	(Note 6- 3) VSM=VSH/2	
		DC	VIDC	VSM-0.1	VSM	VSM+0.1	V		
Digital input voltage		Hi	VIDSH	VSH-1.0	-	VSH	V	MDSH=VSH MDSL=0V	
		Lo	VIDSL	0	-	1.0	V		
Digital input current		Hi	IIDSH	-	-	10.0	uA		
		Lo	IIDSL	-	-	10.0	uA		
COM control signal		AC	VCAC	4.0	5.0	6.0	Vp-p		
		DC	VCDC	0.5	2.0	3.5	V	[Note 6-1]	
CS control signal		AC	VCsAC	4.0	5.0	6.0	Vp-p	[Note 6-1,2, 3,4,5]	
		DC	VCsDC	-3.4	-3.5	-3.6	V		

***** Cautionary Matter : When applying or disconnecting power, please be sure that such action is sequentially carried out for all power supplies. In addition, apply input signals only after power has been turned on.

- ON : VSH → VSS → VCC → VGL → VGH
- OFF : VGH → VGL → VCC → VSS → VSH

[Note 6-1] Any change in voltage adjusting VCDC ,VIDC,VCs DC should be less than 0.1V.

[Note 6-2] The AC element must make it into the same amplitude in the commonness electrode drive signal and the same phase.

[Note 6-3] Positive and negative amplitudes should be equal.

The MIN. value produces a white display and the MAX. value produces a black display.

[Note 6-4] To obtain the maximum value of contrast, each module must be adjusted to an optimum voltage.

[Note 6-5] In case of using Sharp Decoder IC(IR3Y29BM) and inputting standard NTSC signal (Normal mode)

Product Specification
◆ Backlight Driving Section
 $T_a=25^{\circ}\text{C}$

PARAMETER	SYMBOL	MIN.	TYP.	MAX.	UNIT	REMARK
Lamp Current	I_{BL}	3.0	6.0	6.5	mArms	
Lamp Voltage	V_{BL}	660 (6.5mA)	680 (6.0mA)	860 (3.0mA)	Vrms	$\pm 10[\%]$
Lamp Power Consumption	P_{BL}	-	4.08	4.5	Wrms	$I_{BL}=6.0\text{mA}$
Lamp Frequency	f_{BL}	45	-	60	kHz	*1
		45	-	80		*2
Kick-Off Voltage (*3)	V_S	-	-	1300	Vrms	$T_a=25^{\circ}\text{C}$
		-	-	1560	Vrms	$T_a=-30^{\circ}\text{C}$
Discharge Stabilization Time	T_S	-	-	3	Minutes	*4
Life Time	-	20,000	-	-	Hour	*5

- * 1 : This frequency range means the range to keep within $\pm 10\%$ change of electrical and optical characteristics.
- * 2 : This frequency range means not affecting to lamp life and reliability characteristics.
(The lamp frequency should be selected as different as possible from display horizontal synchronous signal (Including harmonic frequency of this scanning frequency) to avoid "Beat" interference which may be observed on the screen as horizontal stripes like moving wave. This phenomenon is caused by interference between lamp (CCFL) lighting frequency and LCD horizontal synchronous signal.)
- * 3 : The "MAX" of "Kick-Off Voltage" means the minimum voltage for inverter to turn on the CCFL normally in the LCD module. However this isn't the values that we can assure stability of starting lamp on condition that the module is installed in your set.
It should be careful that "Kick-Off Voltage" is changed by an increase of stray capacitance in your set, inverter method, value of ballast capacitor in your inverter and so on.
Especially, the value of "Kick-Off Voltage" is higher in low temperature condition than in normal temperature condition, because impedance of CCFL is increased.
- * 4 : The time needed to achieve not less than 95% brightness of the center part of lamp.
The brightness of the lamp after lighted for 5 minutes is defined as 100%.
- * 5 : "Life time" is defined as the lamp brightness decrease to 50% original brightness at $I_{BL}=\text{TYP}$; continuous lighting, $T_a=25^{\circ}\text{C}$.

Product Specification

Requirements for a system inverter design, which is intended to have a better display performance, a better power efficiency and a more reliable lamp, are following. It shall help increase the lamp lifetime and reduce leakage current. Inverter should be designed to be subject to the conditions below

- A. The asymmetry rate of the inverter waveform should be less than 10%.
 - B. The distortion rate of the waveform should be within $\sqrt{2} \pm 10\%$.
- * Inverter output waveform had better be more similar to ideal sine wave.

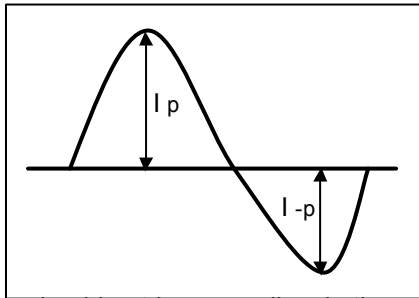

* Asymmetry rate:

$$(I_p - I_{-p}) / I_{rms} * 100\%$$

•Distortion rate:

$$I_p \text{ (or } I_{-p}) / I_{rms}$$

- C. There should not be any spikes in the waveform.
- D. Lamp current should not exceed the "MAX" value under the "Operating Temperature" (it is prohibited to exceed the "MAX." value even if it is operated in the guaranteed temperature).
 When lamp current exceed the maximum value for a long time, it may cause a smoking and ignition.

Therefore, it is recommended that the inverter have the current limited circuit that is used as a protection circuit and/or the lamp current-controlled inverter.

- * Do not attach a conducting tape to lamp connecting wire.
 If the lamp wire attach to a conducting tape, TFT-LCD Module has a low luminance and the inverter has abnormal action. Because leakage current is occurred between lamp wire and conducting tape.

Product Specification
2> Timing Characteristics of input signals
 $T_a=25^{\circ}\text{C}$

PARAMETER	SYMBOL	CONDITION	MIN.	TYP.	MAX.	UNIT	REMARK		
S O U R C E	Clock frequency	f _{CLD}	SAM=L	-	-	5.0	MHz	SSC	
		SAM=H	-	-	12.5				
	High level clock width	t _{WHC}	SAM=L	80.0	-	-	ns		
			SAM=H	30.0	-	-			
	Low level clock width	t _{WLC}	SAM=L	80.0	-	-	ns		
			SAM=H	30.0	-	-			
	Clock rise time	t _{rD}	SAM=L	-	-	20.0	ns		
			SAM=H	-	-	10.0			
	Clock fall time	t _{fD}	SAM=L	-	-	20.0	ns		
			SAM=H	-	-	10.0			
	Data setup time	t _{SUD}		30.0	-	-	ns		SSP_L SSP_R
	Data hold time	t _{HD}		30.0	-	-	ns		
High level width	t _{WHD1}		0.4	-	-	μs			
Rise time	t _{RP}				30.0	ns			
Fall time	t _{FP}				30.0	ns			
G A T E	Clock frequency	f _{CLS}		-	-	80.0	kHz	GSC	
	Minimum clock width	f _{WL}		0.5	-	-			μs
	Clock rise time	t _{rCL}		-	-	100.0			ns
	Clock fall time	t _{fCL}		-	-	100.0			ns
	Data setup time	t _{SUS}		100.0	-	-	ns	GSC,GSP	
	Data hold time	t _{HS}		300.0	-	-	ns		
	Mode set up time	t _{SUM}		300.0	-	-	ns	GSC,MODE2	
	Rise time	t _{rs}		-	-	100.0	ns	GSP	
Fall time	t _{fs}		-	-	100.0	ns			

***** Input Signal Timing Chart : Refer [FIG.4].

Product Specification

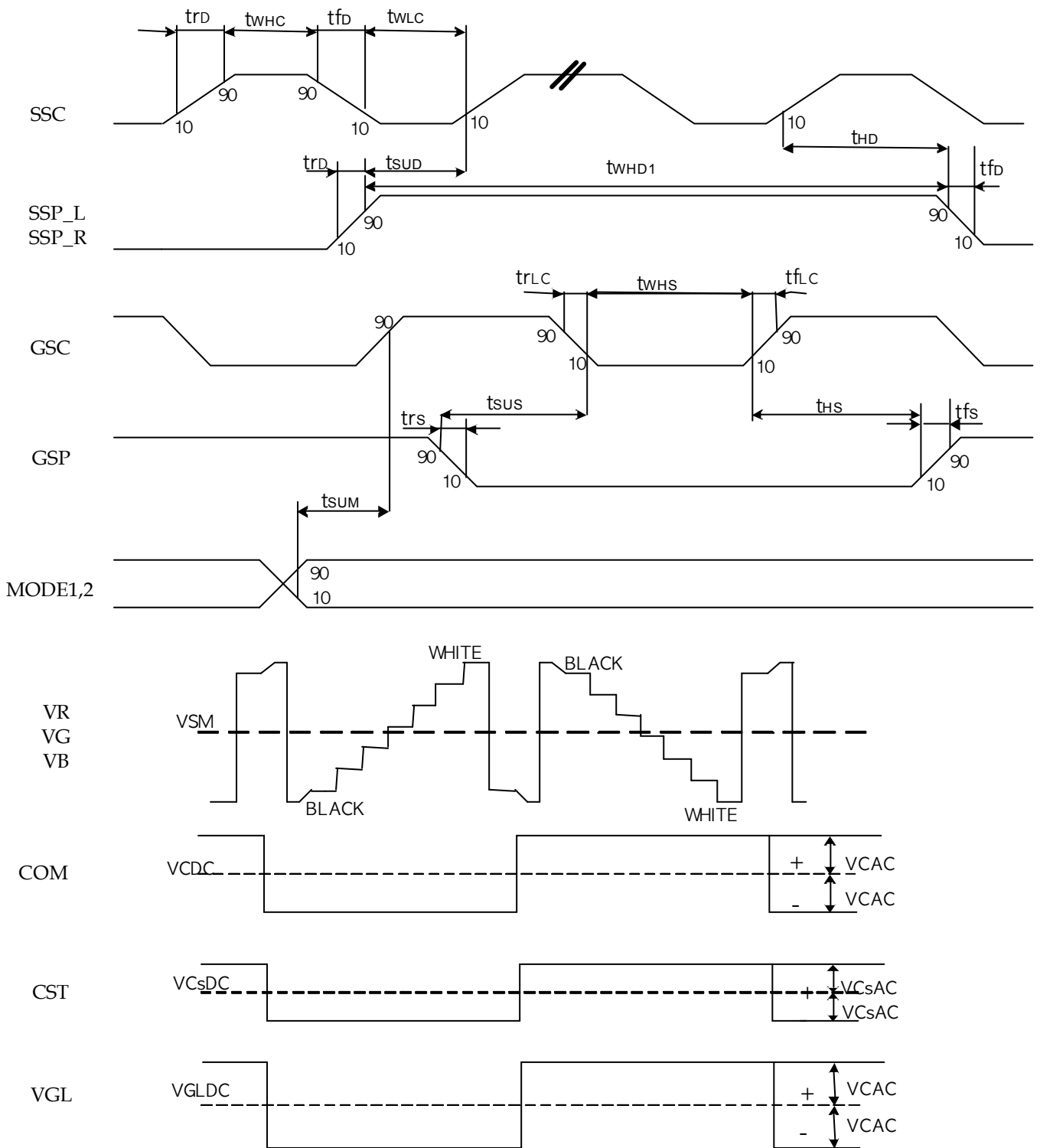

[FIG.4] Input Signal Timing Chart

Product Specification

3> Left/Right,Up/Down terminal (Signal For Reverse Scanning)

MODE	Left/Right	Up/Down	REMARK
Normal Mode	H	L	Refer to the p. 15 [Note 7-3].
Left/Right Reverse Mode	L	L	
Up/Down Reverse Mode	H	H	
Right/Left & Up/Down Reverse Mode	L	H	

* H(High Level) =VSH , L(Low Level)=GND

4> SOE Terminal (Control signal for source driver)

This is control signal of switching sample holder circuit. Please set the high or low level synchronizing with SSP signal during the period each horizontal line.

* High level = VSH, Low level = GND

5> MODE1,2 terminal (Control signal for gate driver)

They are the terminal switching output mode of gate driver.
(Setting to VGL level by force)

MODE1	MODE2	Outputting mode
H	H	Normal mode(1 line writing)
L	H	Out of use
H	L	2 line same time writing mode
L	L	No Outputting

* High level = VSH, Low level = GND

6>SAM terminal (Control signal for source driver)

Used as input pin for setting the selecting of normal sampling operation or 3-point simultaneous sampling operation.

For normal sampling operation (SAM=Hi), video signals are sampled in order
1 LCD source driver output.

For 3-point simultaneous sampling operation(SAM=Lo), video signals are sampled in order
simultaneously 3 LCD drive outputs.

7>Current dissipations

T_a=25°C

PARAMETER		SYMBOL	CONDITION	MN.	TYP.	MAX.	UNIT
Current for source driver	H	I _{SH}	V _{SH} =5.0V	-	35	60	mA
	H	I _{GH}	V _{GH} =13.0V	-	0.1	1.0	mA
Current for gate driver	L	I _{GL}	V _{GLDC} = 10.0V	-	0.1	1.0	mA
	Logic	I _{CC}	V _{CC} = 10.9V	-	0.1	1.0	mA
		I _{SS}	V _{SS} = 16.0V	-	0.1	1.0	mA

In case of using exclusive timing control IC(LPL standard) and inputting standard NTSC signal (Normal mode)

Product Specification

7. Electro-optical Characteristics

$T_a=25^{\circ}\text{C}$

PARAMETER	SYMBOL	CONDITION	MIN.	TYP.	MAX.	UNIT	REMARK
Luminance	Y	$I_{BL}=6\text{mA rms}$	360	450	-	cd/m^2	[Note 7-1]
Contrast Ratio	CR	Optimal	150	400	-	-	[Note 7-2]
White Color Chromaticity	W_x	$I_{BL}=6\text{mA rms}$	0.283	0.313	0.343	-	[Note 7-1]
	W_y		0.299	0.329	0.359	-	
Viewing Angle	$\phi=180^{\circ}$	$\text{CR} \geq 5$	60	65	-	$^{\circ}$	[Note 7-2] [Note 7-3]
	$\phi=0^{\circ}$		60	65	-	$^{\circ}$	
	$\phi=90^{\circ}$		40	50	-	$^{\circ}$	
	$\phi=270^{\circ}$		60	65	-	$^{\circ}$	
Response Time	Rise	$\theta=0^{\circ}$	-	10	20	ms	[Note 7-4]
	Fall		-	30	45	ms	

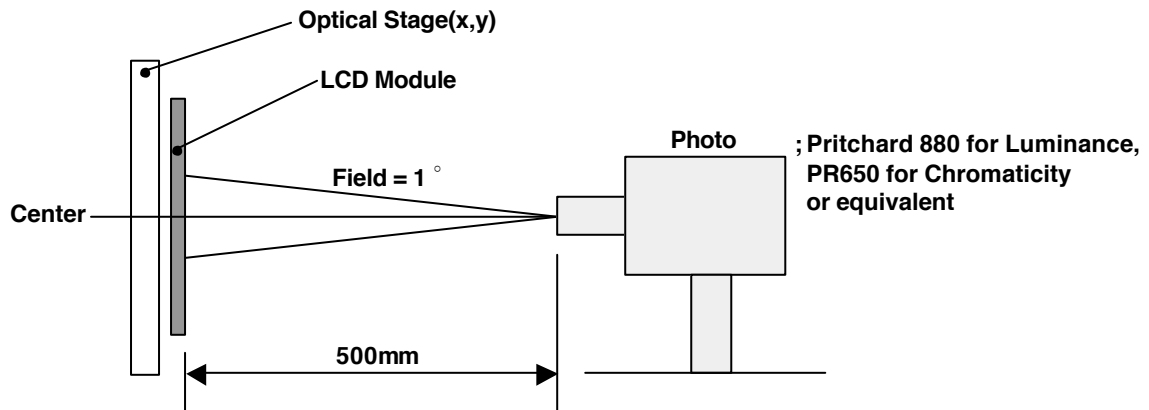

- Measuring Condition ;
- Measuring surroundings : Dark Room
 - Measuring temperature : $T_a=25^{\circ}\text{C}$
 - Adjust operating voltage to get optimum contrast at the center of the display.
 - Measured value at the center point of LCD panel after more than 30 minutes while backlight turning on.

Product Specification

[Note 7-1]

Measured on the center area of the panel by PHOTO RESEARCH photometer PR-880.

[Note 7-2]

Contrast ratio is defined as follows ;

$$\text{Contrast Ratio(CR)} = \frac{\text{Photo detector output with LCD being "white"}}{\text{Photo detector output with LCD being "black"}}$$

[Note 7-3]

Viewing angle range is defined as follows;

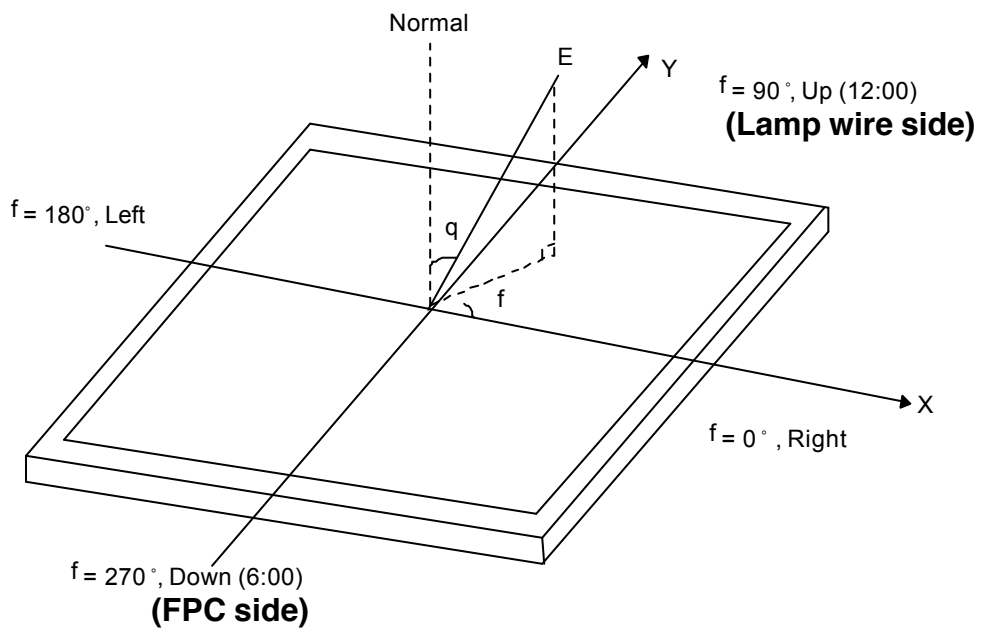

[Normal scanning Mode view]

Product Specification

[Note 7-4]

Response time is obtained by measuring the transition time of photo detector output, when input signals are applied so as to make the area "black" to and from "white".

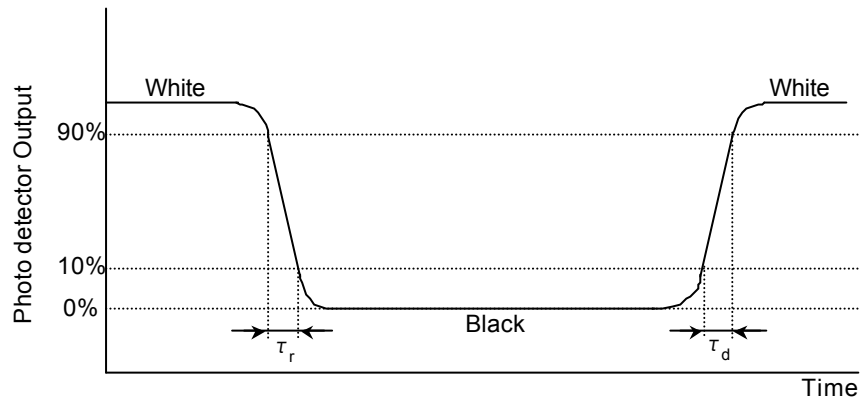

Product Specification

8. Mechanical Characteristics

PARAMETER	SPECIFICATION		UNIT
Outline Dimension	Width	157.2	mm
	Height	89.7	mm
	Depth	8.0 (TYP)	mm
Bezel Area	Width	147.6	mm
	Height	82.9	mm
Active Display Area	Width	143.4	mm
	Height	79.3	mm
Weight	165 (TYP)		g

Product Specification

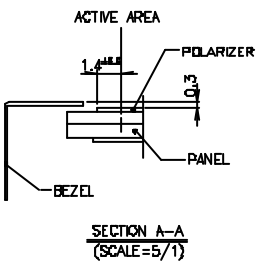
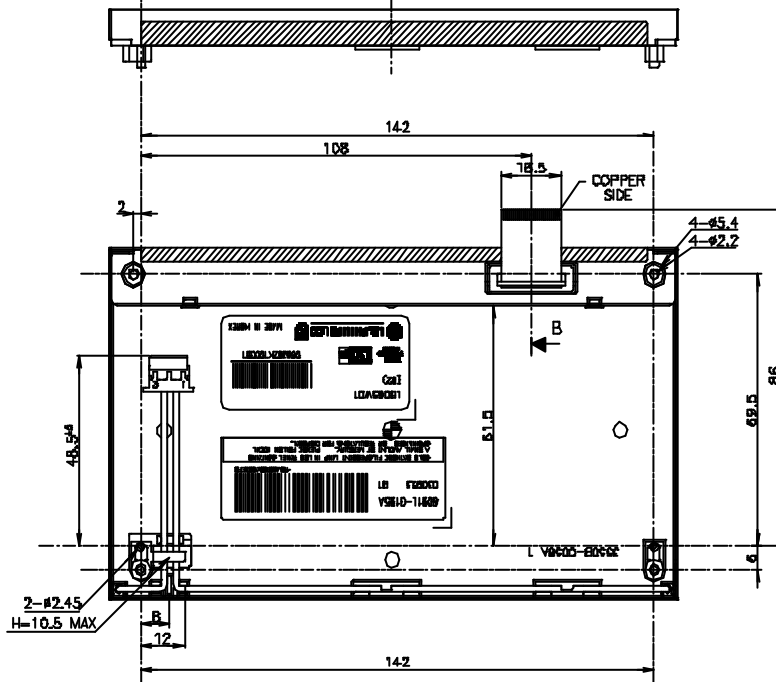
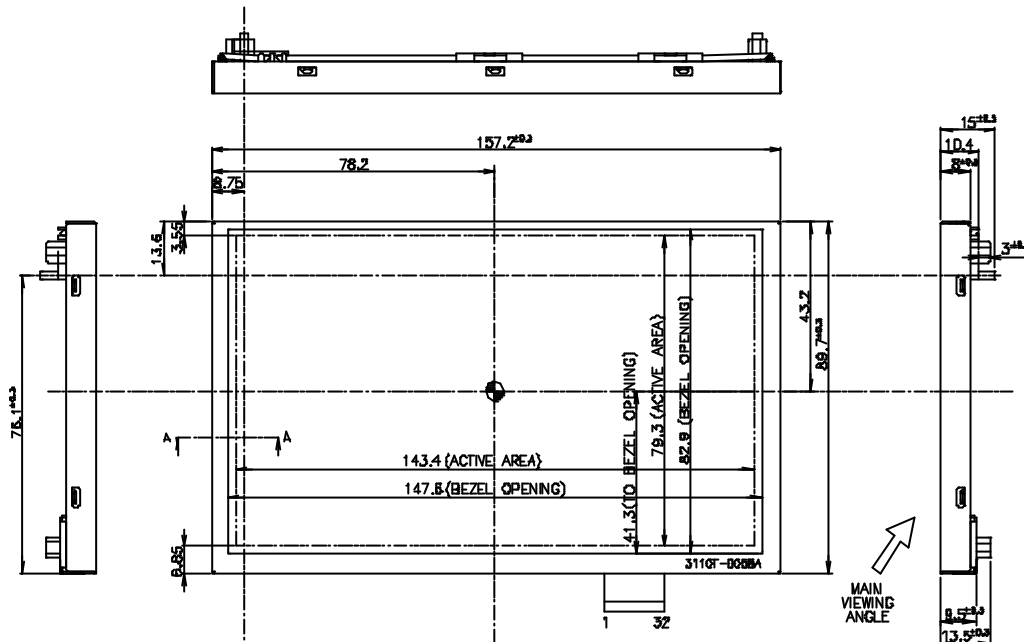

- UNSPECIFIED TOLERANCE IS ±0.3mm
- RECOMMEND SCREW FOR FIX MODULE : TAPPING SCREW M2.6
TAPPING TORQUE : 3.0^{kgf}cm
- B/L CONNECTOR ; BHR-03VS-1(JST) OR EQUIVALENT
MATING CONNECTOR : SMB2(B.D)B-BHS-1-TB(JST) OR EQUIVALENT
- B/L WIRE COLOR & CN PIN ARRAY

PIN NO.	COLOR	VOLTAGE
1	WHITE	LOW
2		
3	PINK	HIGH

DETAIL "B" (S: 4/1)

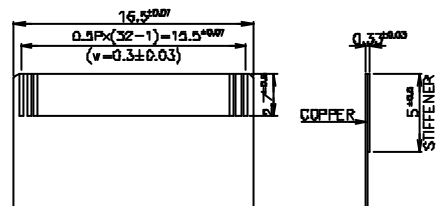

Product Specification
9. Reliability Test

No.	Test Items	Test Condition	REMARK
1	High Temperature Storage Test	Ta=85℃ 240h	
2	Low Temperature Storage Test	Ta=-40℃ 240h	
3	High Temperature Operation Test	Ta=85℃ 50%RH 240h	
4	Low Temperature Operation Test	Ta=-30℃ 240h	
5	High Temperature and High Humidity Operation Test	Ta=65℃ 90%RH 240h	
6	Electro Static Discharge Test	-Panel Surface/Top_Case : 150pF ±15kV 150 Ω (direct discharge, five times) -FPC input terminal : 100pF ±200V 0 Ω	
7	Shock Test (non-operating)	Half sine wave, 80G, 11ms 3 times shock of each six faces	
8	Vibration Test (non-operating)	- 10Hz to 200Hz logarithm sweep for 15min/cycle. - 10Hz to 25Hz:The amplitude is 2 mm. - 25Hz to 200Hz:The acceleration is 2G. - X,Z : 8 cycle, Y : 16 cycle	
9	Thermal Shock Test	-40℃ (0.5h) ~ 85℃ (0.5h) / 100 cycles	

***** T_a= Ambient Temperature

The operating temperature only guarantees operation of the circuit. The contrast, response speed, and the other specification related to electro-optical display quality is determined at the room temperature, T_a ≒ 25℃ .

Product Specification

10. International Standards

10-1. Safety

- a) UL 60950, Third Edition, Underwriters Laboratories, Inc., Dated Dec. 11, 2000.
Standard for Safety of Information Technology Equipment, Including Electrical Business Equipment.
- b) CAN/CSA C22.2, No. 60950, Third Edition, Canadian Standards Association, Dec. 1, 2000.
Standard for Safety of Information Technology Equipment, Including Electrical Business Equipment.
- c) EN 60950 : 2000, Third Edition
IEC 60950 : 1999, Third Edition
European Committee for Electrotechnical Standardization(CENELEC)
EUROPEAN STANDARD for Safety of Information Technology Equipment Including Electrical Business Equipment.

10-2. EMC

- a) ANSI C63.4 "Methods of Measurement of Radio-Noise Emissions from Low-Voltage Electrical and Electrical Equipment in the Range of 9kHz to 40GHz." American National Standards Institute(ANSI), 1992
- b) C.I.S.P.R "Limits and Methods of Measurement of Radio Interface Characteristics of Information Technology Equipment." International Special Committee on Radio Interference.
- c) EN 55022 "Limits and Methods of Measurement of Radio Interface Characteristics of Information Technology Equipment." European Committee for Electrotechnical Standardization.(CENELEC), 1998
(Including A1: 2000)

Product Specification

11. Packing

11-1. Designation of Lot Mark

a) Lot Mark

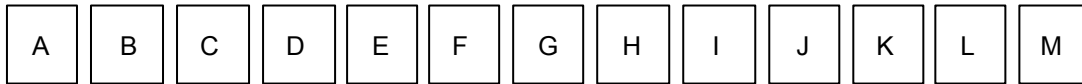

A,B,C : SIZE(INCH)

D : YEAR

F : PANEL CODE

H : ASSEMBLY CODE

E : MONTH

G : FACTORY CODE

I,J,K,L,M : SERIAL NO.

Note

1. YEAR

Year	97	98	99	2000	2001	2002	2003	2004	2005	2006	2007
Mark	7	8	9	0	1	2	3	4	5	6	7

2. MONTH

Month	Jan	Feb	Mar	Apr	May	Jun	Jul	Aug	Sep	Oct	Nov	Dec
Mark	1	2	3	4	5	6	7	8	9	A	B	C

3. PANEL CODE

Panel Code	P1 Factory	P2 Factory	P3 Factory	P4 Factory	P5 Factory	Hydis Panel
Mark	1	2	3	4	5	H

4. FACTORY CODE

Factory Code	LPL Gumi	LPL Nanjing
Mark	K	C

5. SERIAL NO.

Year	1 ~ 99999	100000 ~
Mark	00001 ~ 99999	A0001 ~ A9999, , Z9999

b) Location of Lot Mark

Serial NO. is printed on the label. The label is attached to the backside of the LCD module.
This is subject to change without prior notice.

11-2. Packing Form

a) Package quantity in one box : 18 pcs

b) Box Size : 331 × 277 × 206 (mm)

Product Specification

12. PRECAUTIONS

Please pay attention to the following when you use this TFT LCD module.

12-1. MOUNTING PRECAUTIONS

- (1) You must mount a module using holes arranged in four corners or four sides.
- (2) You should consider the mounting structure so that uneven force(ex. Twisted stress) is not applied to the module.
And the case on which a module is mounted should have sufficient strength so that external force is not transmitted directly to the module.
- (3) Please attach a transparent protective plate to the surface in order to protect the polarizer.
Transparent protective plate should have sufficient strength in order to resist external force.
- (4) You should adopt radiation structure to satisfy the temperature specification.
- (5) Acetic acid type and chlorine type materials for the cover case are not desirable because the former generates corrosive gas of attacking the polarizer at high temperature and the latter causes circuit break by electro-chemical reaction.
- (6) Do not touch, push or rub the exposed polarizers with glass, tweezers or anything harder than HB pencil lead. And please do not rub with dust clothes with chemical treatment.
Do not touch the surface of polarizer for bare hand or greasy cloth.(Some cosmetics deteriorate the polarizer.)
- (7) When the surface becomes dusty, please wipe gently with absorbent cotton or other soft materials like chamois soaks with petroleum benzine. Normal-hexane is recommended for cleaning the adhesives used to attach front / rear polarizers. Do not use acetone, toluene and alcohol because they cause chemical damage to the polarizer.
- (8) Wipe off saliva or water drops as soon as possible. Their long time contact with polarizer causes deformations and color fading.
- (9) Do not open the case because inside circuits do not have sufficient strength.
- (10) The metal case of a module should be contacted to electrical ground of your system.

12-2. OPERATING PRECAUTIONS

- (1) The spike noise causes the mis-operation of circuits. It should be lower than following voltage :
 $V = \pm 200\text{mV}$ (Over and under shoot voltage)
- (2) Response time depends on the temperature.(In lower temperature, it becomes longer.)
- (3) Brightness depends on the temperature. (In lower temperature, it becomes lower.)
And in lower temperature, response time(required time that brightness is stable after turned on) becomes longer.
- (4) Be careful for condensation at sudden temperature change. Condensation makes damage to polarizer or electrical contacted parts. And after fading condensation, smear or spot will occur.
- (5) When fixed patterns are displayed for a long time, remnant image is likely to occur.
- (6) Module has high frequency circuits. Sufficient suppression to the electromagnetic interference shall be done by system manufacturers. Grounding and shielding methods may be important to minimize the interference.

Product Specification

12-3. ELECTROSTATIC DISCHARGE CONTROL

Since a module is composed of electronic circuits, it is not strong to electrostatic discharge. Make certain that treatment persons are connected to ground through wrist band etc. And don't touch interface pin directly.

12-4. PRECAUTIONS FOR STRONG LIGHT EXPOSURE

Strong light exposure causes degradation of polarizer and color filter.

12-5. STORAGE

When storing modules as spares for a long time, the following precautions are necessary.

- (1) Store them in a dark place. Do not expose the module to sunlight or fluorescent light. Keep the temperature between 5°C and 35°C at normal humidity.
- (2) The polarizer surface should not come in contact with any other object.
It is recommended that they be stored in the container in which they were shipped.

12-6. HANDLING PRECAUTIONS FOR PROTECTION FILM

- (1) When the protection film is peeled off, static electricity is generated between the film and polarizer. This should be peeled off slowly and carefully by people who are electrically grounded and with well ion-blown equipment or in such a condition, etc.
- (2) The protection film is attached to the polarizer with a small amount of glue. If some stress is applied to rub the protection film against the polarizer during the time you peel off the film, the glue is apt to remain on the polarizer.
Please carefully peel off the protection film without rubbing it against the polarizer.
- (3) When the module with protection film attached is stored for a long time, sometimes there remains a very small amount of glue still on the polarizer after the protection film is peeled off.
- (4) You can remove the glue easily. When the glue remains on the polarizer surface or its vestige is recognized, please wipe them off with absorbent cotton waste or other soft material like chamois soaked with normal-hexane.