

Product Specification

# SPECIFICATION FOR APPROVAL

- (●) Preliminary Specification  
( ) Final Specification

<b>Title</b>	<b>2.2" qCIF+ TFT LCD</b>
--------------	---------------------------

BUYER	General
MODEL	-

SUPPLIER	LG.Philips LCD Co., Ltd.
*MODEL	LH220J01
SUFFIX	TD01

\*When you obtain standard approval, please use the above model name without suffix.

SIGNATURE	DATE
/	_____
/	_____
/	_____

APPROVED BY	DATE
H.W. KIM /G.Manager	_____
<b>REVIEWED BY</b>	
Y.T. WOO /Manager	_____
<b>PREPARED BY</b>	
B.H. PARK /Engineer	_____

Please return 1 copy for your confirmation with your signature and comments.

**Product Engineering Dept.  
LG. Philips LCD Co., Ltd**

**Product Specification**

**CONTENTS**

No	ITEM	Page
	COVER	1
	CONTENTS	2
	RECORD OF REVISIONS	3
1	GENERAL DESCRIPTION	4
2	ABSOLUTE MAXIMUM RATINGS	5
3	ELECTRICAL SPECIFICATIONS	6
3-1	ELECTRICAL CHARACTREISTICS	6
3-2	BACK LIGHT UNIT	6
3-3	INTERFACE CONNECTIONS	7
3-4	SIGNAL TIMING SPECIFICATIONS	11
3-5	SIGNAL TIMING WAVEFORMS	12
3-6	COLOR INPUT DATA REFERNECE	13
4	OPTICAL CHARACTERISTICS	14
5	MECHANICAL CHARACTERISTICS	18
6	POWER SUPPLY SEQUENCE	22
7	DISPLAY SEQUENCE	25
8	STAND BY & SLEEP SEQUENCE	26
9	RELIABLITY	27
10	INTERNATIONAL STANDARDS	28
11	PACKING	29
12	PRECAUTIONS	31



## Product Specification

### 1. GENERAL DESCRIPTION

The LH220J01 is a Color Active Matrix Liquid Crystal Display with Light Emission Diode(LED) backlight system. The matrix employs a-Si Thin Film Transistor as the active element. It is transmissive type display operating in the normally white mode. This TFT-LCD has 2.2 inch diagonally measured active display area with qCIF+(176\*RGB\*220) resolution. Each pixel is divided into Red, Green and Blue sub-pixels or dots which are arranged in vertical stripes.

### Block Diagram

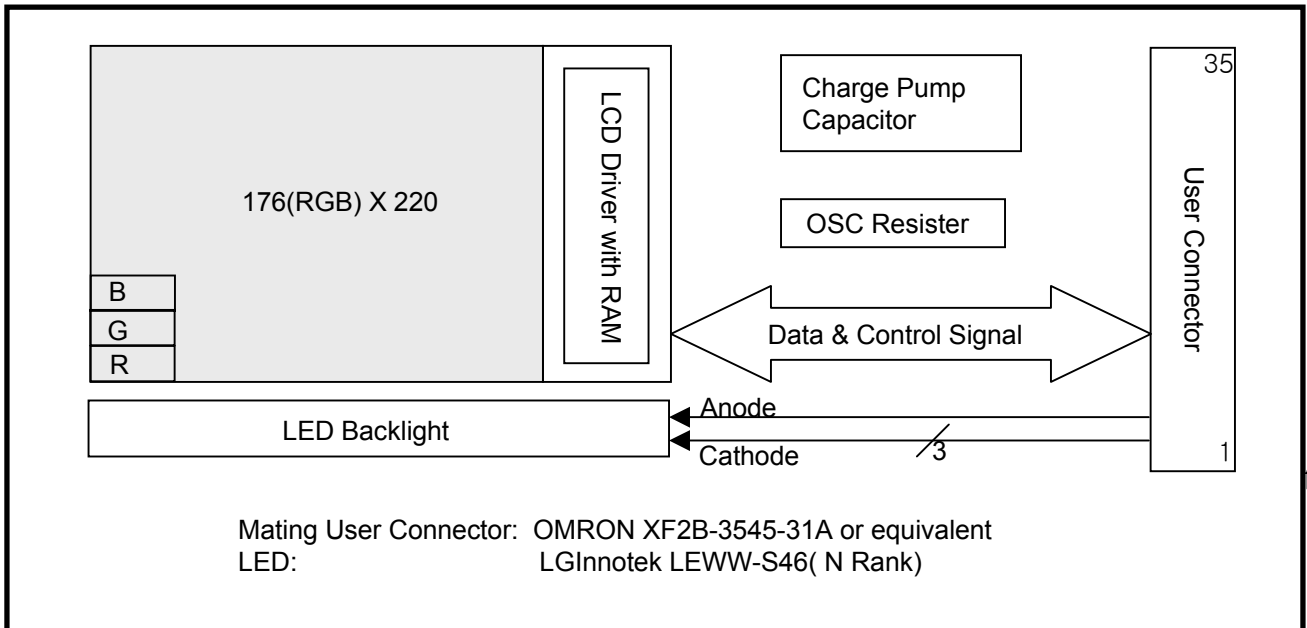

**Fig 1.1 Block Diagram of TFT-LCD Module with LED Backlight Unit**

### General Features

Active screen size	2.2" inches diagonal
Outline Dimension	40.9 (W) X 54.36 (H) X 2.0 (D) MM (TYP.)
Pixel Pitch	0.198 (H) X 0.198 (V) mm
Pixel format	176(H) X 220 (V) (RGB Stripe)
Color depth	18-bits (6R, 6G, 6B used)
Interface	16-bit CPU bus, 8-bit Compatible
Power Consumption	T.B.D
Brightness	200nit(min.)
Viewing Direction	12 o'clock
Weight	8.5g(Typ.)
Surface treatment	Hard Coating(2H)
LCD Driver	COG 1Chip

**Product Specification**

**2. ABSOLUTE MAXIMUM RATINGS**

The following are maximum values which, if exceeded, may cause faulty operation or damage to the unit.

**Table 2.1 Absolute Maximum Ratings**

Parameter	Symbol	Values		Units	Notes
		Min.	Max		
Power Supply Input	$V_{CC}$	-0.3	4.6	V	1
LED Power Consumption	$P_{LED}$	-	93.7	mW	2
LED Current	$I_{LED}$	-	25	mA	2, 3

Notes:

1. Applies to  $V_{CC}$ , RES, RS, CS, WR, D0-D15, IM0, IM3 and FLM.
2. Applies for each LED individually.
3. Allowable forward current is refer to Fig 2.1

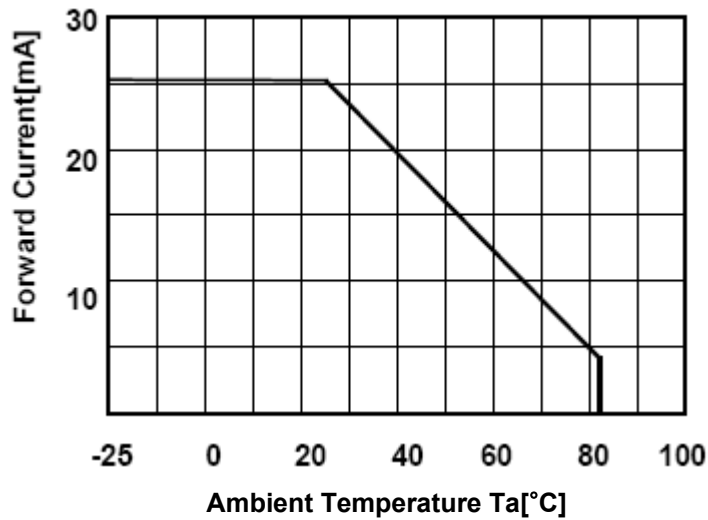

**Fig 2.1 Ambient Temperature vs. Allowable Forward Current**

**Product Specification**

**3. ELECTRICAL SPECIFICATIONS**

**3-1. ELECTRICAL CHARACTERISTICS**

**Table 3.1 Electrical Characteristics Of TFT-LCD Module**

Parameter	Symbol	Values			Units	Notes
		Min	Typ.	Max		
LCD Power Supply Voltage	$V_{CC}$	2.5	2.8	3.3	V	
“H”Level Input Voltage	$V_{IH}$	$0.8 V_{CC}$	-	$V_{CC}$	V	2
“L”Level Input Voltage	$V_{IL}$	-0.3	-	$0.2V_{CC}$	V	2
“H”Level Output Voltage	$V_{OH}$	$0.8 V_{CC}$	-	-	V	3
“L”Level Output Voltage	$V_{OL}$	-	-	$0.2 V_{CC}$	V	3
Power Consumption, Panel	$P_{LCD}$		T.B.D		mW	
Power Consumption, Standby	$P_S$		T.B.D		uW	

Notes:

1. The specified current and power consumption are under the conditions at  $V_{CC} = 2.8V$ ,  $T_a=25^{\circ}C$ , and  $f_v=70Hz$ , Black pattern is displayed and  $f_v$  is the frame frequency.
2. Input mode of D[15:0], RES, RS, RD, WR, CS, IM0, IM3.
3. Output mode of D [15:0], FLM.

**3-2. BACK LIGHT UNIT**

The edge-lighting type of back light unit consists of 3 LEDs which is connected in parallel.

**Table 3.2 Electrical Characteristics Of Back Light Unit**

Parameter	Symbol	Values			Units	Notes
		Min	Typ.	Max		
LED Current	$I_{LED}$	-	20	25	mA	
LED Forward Voltage	$V_{LED}$	-	3.3	3.75	V	
LED Power Consumption	$P_{LED}$	-	198	225	mW	@ Typ current

## Product Specification

### 3-3. INTERFACE CONNECTIONS

The pin connections are provided in Table 3.1. The mating connector for the flex tail is XF2B-3545-31A Or equivalent.

**Table 3.3 Module Connector Pin Configuration**

Pin	SYMBOL	I/O	Description	Comment
1	GND	-	Ground	-
2	LED1	-	LED Cathode	-
3	LED2	-	LED Cathode	-
4	LED3	-	LED Cathode	-
5	VLED	-	LED Anode	-
6	VLED	-	LED Anode	-
7	FLM	O	Interrupt request to the host bus	Indicates start of frame
8	CS	I	Chip select input	"L" active
9	RS	I	Resister select input	-
10	WR	I	Write control input	"L" active
11	RD	I	Read control input	"L" active
12	GND	-	Ground	-
13	D0	I/O	Data Bus(LSB)	LCD Driver (DB1)
14	D1	I/O	Data Bus	LCD Driver (DB2)
15	D2	I/O	Data Bus	LCD Driver (DB3)
16	D3	I/O	Data Bus	LCD Driver (DB4)
17	D4	I/O	Data Bus	LCD Driver (DB5)
18	D5	I/O	Data Bus	LCD Driver (DB6)
19	D6	I/O	Data Bus	LCD Driver (DB7)
20	D7	I/O	Data Bus	LCD Driver (DB8)
21	D8	I/O	Data Bus	LCD Driver (DB10)
22	D9	I/O	Data Bus	LCD Driver (DB11)
23	D10	I/O	Data Bus	LCD Driver (DB12)
24	D11	I/O	Data Bus	LCD Driver (DB13)
25	D12	I/O	Data Bus	LCD Driver (DB14)
26	D13	I/O	Data Bus	LCD Driver (DB15)
27	D14	I/O	Data Bus	LCD Driver (DB16)
28	D15	I/O	Data Bus(MSB)	LCD Driver (DB17)
29	RES	I	Reset signal input	"L" active
30	IM3	I	System Interface Mode Select	LCD Driver (IM3)
31	IM0	I	System Interface Mode Select	LCD Driver (IM0)
32	GND	-	Ground	-
33	VCC	-	LCD Power Supply	-
34	VCC	-	LCD Power Supply	-
35	GND	I/O	Driver Version	Connected to GND

**Product Specification**

**Table 3.4 System Interface Mode Select**

IM3	IM0	Description
0	0	80-System 16-bit Interface(Will use D0~D15 as Data Bus)
0	1	80-System 8-bit Interface(Will use D8~D15 as Data Bus, D0~D7 Set to "HIGH" or "LOW")

**Table 3.5 Register Selection( 80-system Parallel Interface )**

WR	RD	RS	Description
0	1	0	Write an index to IR(16-bit Index Register)
1	0	0	Read an internal status
0	1	1	Write to control registers or the internal GRAM via WDR(18-bit write data register)
1	0	1	Read from the internal GRAM via RDR

**Table 3.6 16-bit Instruction data format**

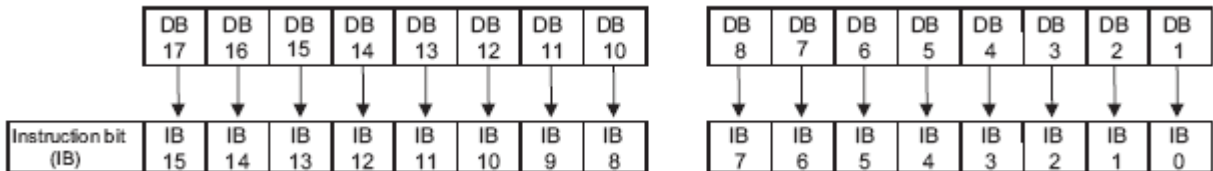

**Table 3.7 8-bit Instruction data format**

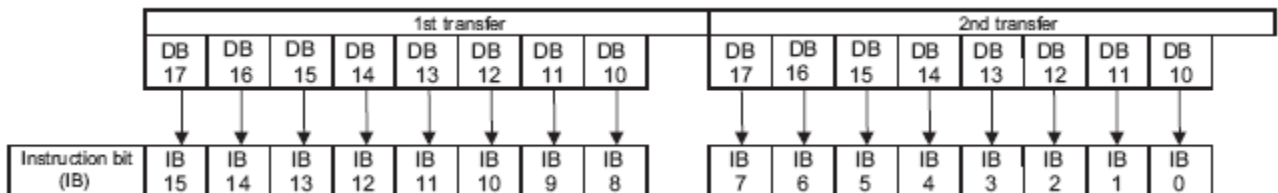



## Product Specification

**Table 3.8 GRAM Data and 16-bit Display Interface**

TRI	DFM 1	DFM 0	16-bit interface RAM interface format																																																								
0	0	0	<p>80-system 16-bit interface (1 transfer/pixel) 65,536 colors</p> <div style="text-align: center;"> <table border="1" style="margin: auto;"> <tr> <td colspan="16">first transfer</td> </tr> <tr> <td>GRAM data</td><td>DB 17</td><td>DB 16</td><td>DB 15</td><td>DB 14</td><td>DB 13</td><td>DB 12</td><td>DB 11</td><td>DB 10</td><td>DB 8</td><td>DB 7</td><td>DB 6</td><td>DB 5</td><td>DB 4</td><td>DB 3</td><td>DB 2</td><td>DB 1</td> </tr> <tr> <td>RGB data</td><td>R5</td><td>R4</td><td>R3</td><td>R2</td><td>R1</td><td>1</td><td>G5</td><td>G4</td><td>G3</td><td>G2</td><td>G1</td><td>G0</td><td>B5</td><td>B4</td><td>B3</td><td>B2</td><td>B1</td><td>1</td> </tr> </table> </div>	first transfer																GRAM data	DB 17	DB 16	DB 15	DB 14	DB 13	DB 12	DB 11	DB 10	DB 8	DB 7	DB 6	DB 5	DB 4	DB 3	DB 2	DB 1	RGB data	R5	R4	R3	R2	R1	1	G5	G4	G3	G2	G1	G0	B5	B4	B3	B2	B1	1				
first transfer																																																											
GRAM data	DB 17	DB 16	DB 15	DB 14	DB 13	DB 12	DB 11	DB 10	DB 8	DB 7	DB 6	DB 5	DB 4	DB 3	DB 2	DB 1																																											
RGB data	R5	R4	R3	R2	R1	1	G5	G4	G3	G2	G1	G0	B5	B4	B3	B2	B1	1																																									
0	0	1	<p>80-system 16-bit interface (1 transfer/pixel) 65,536 colors</p> <div style="text-align: center;"> <table border="1" style="margin: auto;"> <tr> <td colspan="16">first transfer</td> </tr> <tr> <td>GRAM data</td><td>DB 17</td><td>DB 16</td><td>DB 15</td><td>DB 14</td><td>DB 13</td><td>DB 12</td><td>DB 11</td><td>DB 10</td><td>DB 8</td><td>DB 7</td><td>DB 6</td><td>DB 5</td><td>DB 4</td><td>DB 3</td><td>DB 2</td><td>DB 1</td> </tr> <tr> <td>RGB data</td><td>R5</td><td>R4</td><td>R3</td><td>R2</td><td>R1</td><td>0</td><td>G5</td><td>G4</td><td>G3</td><td>G2</td><td>G1</td><td>G0</td><td>B5</td><td>B4</td><td>B3</td><td>B2</td><td>B1</td><td>0</td> </tr> </table> </div>	first transfer																GRAM data	DB 17	DB 16	DB 15	DB 14	DB 13	DB 12	DB 11	DB 10	DB 8	DB 7	DB 6	DB 5	DB 4	DB 3	DB 2	DB 1	RGB data	R5	R4	R3	R2	R1	0	G5	G4	G3	G2	G1	G0	B5	B4	B3	B2	B1	0				
first transfer																																																											
GRAM data	DB 17	DB 16	DB 15	DB 14	DB 13	DB 12	DB 11	DB 10	DB 8	DB 7	DB 6	DB 5	DB 4	DB 3	DB 2	DB 1																																											
RGB data	R5	R4	R3	R2	R1	0	G5	G4	G3	G2	G1	G0	B5	B4	B3	B2	B1	0																																									
0	1	0	<p>80-system 16-bit interface (1 transfer/pixel) 65,536 colors</p> <div style="text-align: center;"> <table border="1" style="margin: auto;"> <tr> <td colspan="16">first transfer</td> </tr> <tr> <td>GRAM data</td><td>DB 17</td><td>DB 16</td><td>DB 15</td><td>DB 14</td><td>DB 13</td><td>DB 12</td><td>DB 11</td><td>DB 10</td><td>DB 8</td><td>DB 7</td><td>DB 6</td><td>DB 5</td><td>DB 4</td><td>DB 3</td><td>DB 2</td><td>DB 1</td> </tr> <tr> <td>RGB data</td><td>R5</td><td>R4</td><td>R3</td><td>R2</td><td>R1</td><td>R0</td><td>G5</td><td>G4</td><td>G3</td><td>G2</td><td>G1</td><td>G0</td><td>B5</td><td>B4</td><td>B3</td><td>B2</td><td>B1</td><td>B0</td> </tr> </table> </div>	first transfer																GRAM data	DB 17	DB 16	DB 15	DB 14	DB 13	DB 12	DB 11	DB 10	DB 8	DB 7	DB 6	DB 5	DB 4	DB 3	DB 2	DB 1	RGB data	R5	R4	R3	R2	R1	R0	G5	G4	G3	G2	G1	G0	B5	B4	B3	B2	B1	B0				
first transfer																																																											
GRAM data	DB 17	DB 16	DB 15	DB 14	DB 13	DB 12	DB 11	DB 10	DB 8	DB 7	DB 6	DB 5	DB 4	DB 3	DB 2	DB 1																																											
RGB data	R5	R4	R3	R2	R1	R0	G5	G4	G3	G2	G1	G0	B5	B4	B3	B2	B1	B0																																									
0	1	1	Setting disabled																																																								
1	0	*	<p>80-system 16-bit interface (2 transfers/pixel) 262,144 colors</p> <div style="text-align: center;"> <table border="1" style="margin: auto;"> <tr> <td colspan="16">first transfer</td> <td colspan="2">second transfer</td> </tr> <tr> <td>GRAM data</td><td>DB 17</td><td>DB 16</td><td>DB 15</td><td>DB 14</td><td>DB 13</td><td>DB 12</td><td>DB 11</td><td>DB 10</td><td>DB 8</td><td>DB 7</td><td>DB 6</td><td>DB 5</td><td>DB 4</td><td>DB 3</td><td>DB 2</td><td>DB 1</td><td>DB 17</td><td>DB 16</td> </tr> <tr> <td>RGB data</td><td>R5</td><td>R4</td><td>R3</td><td>R2</td><td>R1</td><td>R0</td><td>G5</td><td>G4</td><td>G3</td><td>G2</td><td>G1</td><td>G0</td><td>B5</td><td>B4</td><td>B3</td><td>B2</td><td>B1</td><td>B0</td> </tr> </table> </div>	first transfer																second transfer		GRAM data	DB 17	DB 16	DB 15	DB 14	DB 13	DB 12	DB 11	DB 10	DB 8	DB 7	DB 6	DB 5	DB 4	DB 3	DB 2	DB 1	DB 17	DB 16	RGB data	R5	R4	R3	R2	R1	R0	G5	G4	G3	G2	G1	G0	B5	B4	B3	B2	B1	B0
first transfer																second transfer																																											
GRAM data	DB 17	DB 16	DB 15	DB 14	DB 13	DB 12	DB 11	DB 10	DB 8	DB 7	DB 6	DB 5	DB 4	DB 3	DB 2	DB 1	DB 17	DB 16																																									
RGB data	R5	R4	R3	R2	R1	R0	G5	G4	G3	G2	G1	G0	B5	B4	B3	B2	B1	B0																																									
1	1	*	<p>80-system 16-bit interface (2 transfers/pixel) 262,144 colors</p> <div style="text-align: center;"> <table border="1" style="margin: auto;"> <tr> <td colspan="2">first transfer</td> <td colspan="16">second transfer</td> </tr> <tr> <td>GRAM data</td><td>DB 2</td><td>DB 1</td><td>DB 17</td><td>DB 16</td><td>DB 15</td><td>DB 14</td><td>DB 13</td><td>DB 12</td><td>DB 11</td><td>DB 10</td><td>DB 8</td><td>DB 7</td><td>DB 6</td><td>DB 5</td><td>DB 4</td><td>DB 3</td><td>DB 2</td><td>DB 1</td> </tr> <tr> <td>RGB data</td><td>R5</td><td>R4</td><td>R3</td><td>R2</td><td>R1</td><td>R0</td><td>G5</td><td>G4</td><td>G3</td><td>G2</td><td>G1</td><td>G0</td><td>B5</td><td>B4</td><td>B3</td><td>B2</td><td>B1</td><td>B0</td> </tr> </table> </div>	first transfer		second transfer																GRAM data	DB 2	DB 1	DB 17	DB 16	DB 15	DB 14	DB 13	DB 12	DB 11	DB 10	DB 8	DB 7	DB 6	DB 5	DB 4	DB 3	DB 2	DB 1	RGB data	R5	R4	R3	R2	R1	R0	G5	G4	G3	G2	G1	G0	B5	B4	B3	B2	B1	B0
first transfer		second transfer																																																									
GRAM data	DB 2	DB 1	DB 17	DB 16	DB 15	DB 14	DB 13	DB 12	DB 11	DB 10	DB 8	DB 7	DB 6	DB 5	DB 4	DB 3	DB 2	DB 1																																									
RGB data	R5	R4	R3	R2	R1	R0	G5	G4	G3	G2	G1	G0	B5	B4	B3	B2	B1	B0																																									

**Product Specification**

**Table 3.9 GRAM Data and 8-bit Display Interface**

TRI	DFM 1	DFM 0	8-bit interface RAM interface format																																																				
0	0	0	<p>80-system 8-bit interface (2 transfers/pixel) 65,536 colors</p> <table border="1"> <tr> <td colspan="8">first transfer</td> <td colspan="8">second transfer</td> </tr> <tr> <td>GRAM data</td> <td>DB 17</td><td>DB 16</td><td>DB 15</td><td>DB 14</td><td>DB 13</td><td>DB 12</td><td>DB 11</td><td>DB 10</td> <td>DB 8</td><td>DB 7</td><td>DB 6</td><td>DB 5</td><td>DB 4</td><td>DB 3</td><td>DB 2</td><td>DB 1</td> </tr> <tr> <td>RGB data</td> <td>R5</td><td>R4</td><td>R3</td><td>R2</td><td>R1</td><td>1</td><td>G5</td><td>G4</td><td>G3</td><td>G2</td><td>G1</td><td>G0</td><td>B5</td><td>B4</td><td>B3</td><td>B2</td><td>B1</td><td>1</td> </tr> </table>	first transfer								second transfer								GRAM data	DB 17	DB 16	DB 15	DB 14	DB 13	DB 12	DB 11	DB 10	DB 8	DB 7	DB 6	DB 5	DB 4	DB 3	DB 2	DB 1	RGB data	R5	R4	R3	R2	R1	1	G5	G4	G3	G2	G1	G0	B5	B4	B3	B2	B1	1
first transfer								second transfer																																															
GRAM data	DB 17	DB 16	DB 15	DB 14	DB 13	DB 12	DB 11	DB 10	DB 8	DB 7	DB 6	DB 5	DB 4	DB 3	DB 2	DB 1																																							
RGB data	R5	R4	R3	R2	R1	1	G5	G4	G3	G2	G1	G0	B5	B4	B3	B2	B1	1																																					
0	0	1	<p>80-system 8-bit interface (2 transfers/pixel) 65,536 colors</p> <table border="1"> <tr> <td colspan="8">first transfer</td> <td colspan="8">second transfer</td> </tr> <tr> <td>GRAM data</td> <td>DB 17</td><td>DB 16</td><td>DB 15</td><td>DB 14</td><td>DB 13</td><td>DB 12</td><td>DB 11</td><td>DB 10</td> <td>DB 8</td><td>DB 7</td><td>DB 6</td><td>DB 5</td><td>DB 4</td><td>DB 3</td><td>DB 2</td><td>DB 1</td> </tr> <tr> <td>RGB data</td> <td>R5</td><td>R4</td><td>R3</td><td>R2</td><td>R1</td><td>0</td><td>G5</td><td>G4</td><td>G3</td><td>G2</td><td>G1</td><td>G0</td><td>B5</td><td>B4</td><td>B3</td><td>B2</td><td>B1</td><td>0</td> </tr> </table>	first transfer								second transfer								GRAM data	DB 17	DB 16	DB 15	DB 14	DB 13	DB 12	DB 11	DB 10	DB 8	DB 7	DB 6	DB 5	DB 4	DB 3	DB 2	DB 1	RGB data	R5	R4	R3	R2	R1	0	G5	G4	G3	G2	G1	G0	B5	B4	B3	B2	B1	0
first transfer								second transfer																																															
GRAM data	DB 17	DB 16	DB 15	DB 14	DB 13	DB 12	DB 11	DB 10	DB 8	DB 7	DB 6	DB 5	DB 4	DB 3	DB 2	DB 1																																							
RGB data	R5	R4	R3	R2	R1	0	G5	G4	G3	G2	G1	G0	B5	B4	B3	B2	B1	0																																					
0	1	0	<p>80-system 8-bit interface (2 transfers/pixel) 65,536 colors</p> <table border="1"> <tr> <td colspan="8">first transfer</td> <td colspan="8">second transfer</td> </tr> <tr> <td>GRAM data</td> <td>DB 17</td><td>DB 16</td><td>DB 15</td><td>DB 14</td><td>DB 13</td><td>DB 12</td><td>DB 11</td><td>DB 10</td> <td>DB 8</td><td>DB 7</td><td>DB 6</td><td>DB 5</td><td>DB 4</td><td>DB 3</td><td>DB 2</td><td>DB 1</td> </tr> <tr> <td>RGB data</td> <td>R5</td><td>R4</td><td>R3</td><td>R2</td><td>R1</td><td>R0</td><td>G5</td><td>G4</td><td>G3</td><td>G2</td><td>G1</td><td>G0</td><td>B5</td><td>B4</td><td>B3</td><td>B2</td><td>B1</td><td>B0</td> </tr> </table>	first transfer								second transfer								GRAM data	DB 17	DB 16	DB 15	DB 14	DB 13	DB 12	DB 11	DB 10	DB 8	DB 7	DB 6	DB 5	DB 4	DB 3	DB 2	DB 1	RGB data	R5	R4	R3	R2	R1	R0	G5	G4	G3	G2	G1	G0	B5	B4	B3	B2	B1	B0
first transfer								second transfer																																															
GRAM data	DB 17	DB 16	DB 15	DB 14	DB 13	DB 12	DB 11	DB 10	DB 8	DB 7	DB 6	DB 5	DB 4	DB 3	DB 2	DB 1																																							
RGB data	R5	R4	R3	R2	R1	R0	G5	G4	G3	G2	G1	G0	B5	B4	B3	B2	B1	B0																																					
0	1	1	Setting disabled																																																				
1	0	*	<p>80-system 8-bit interface (3 transfers/pixel) 262,144 colors</p> <table border="1"> <tr> <td>first transfer</td> <td colspan="6">second transfer</td> <td colspan="6">third transfer</td> </tr> <tr> <td>GRAM data</td> <td>DB 11</td><td>DB 10</td><td>DB 17</td><td>DB 16</td><td>DB 15</td><td>DB 14</td><td>DB 13</td><td>DB 12</td><td>DB 11</td><td>DB 10</td> <td>DB 17</td><td>DB 16</td><td>DB 15</td><td>DB 14</td><td>DB 13</td><td>DB 12</td><td>DB 11</td><td>DB 10</td> </tr> <tr> <td>RGB data</td> <td>R5</td><td>R4</td><td>R3</td><td>R2</td><td>R1</td><td>R0</td><td>G5</td><td>G4</td><td>G3</td><td>G2</td><td>G1</td><td>G0</td><td>B5</td><td>B4</td><td>B3</td><td>B2</td><td>B1</td><td>B0</td> </tr> </table>	first transfer	second transfer						third transfer						GRAM data	DB 11	DB 10	DB 17	DB 16	DB 15	DB 14	DB 13	DB 12	DB 11	DB 10	DB 17	DB 16	DB 15	DB 14	DB 13	DB 12	DB 11	DB 10	RGB data	R5	R4	R3	R2	R1	R0	G5	G4	G3	G2	G1	G0	B5	B4	B3	B2	B1	B0	
first transfer	second transfer						third transfer																																																
GRAM data	DB 11	DB 10	DB 17	DB 16	DB 15	DB 14	DB 13	DB 12	DB 11	DB 10	DB 17	DB 16	DB 15	DB 14	DB 13	DB 12	DB 11	DB 10																																					
RGB data	R5	R4	R3	R2	R1	R0	G5	G4	G3	G2	G1	G0	B5	B4	B3	B2	B1	B0																																					
1	1	*	<p>80-system 8-bit interface (3 transfers/pixel) 262,144 colors</p> <table border="1"> <tr> <td>first transfer</td> <td colspan="6">second transfer</td> <td colspan="6">third transfer</td> </tr> <tr> <td>GRAM data</td> <td>DB 17</td><td>DB 16</td><td>DB 15</td><td>DB 14</td><td>DB 13</td><td>DB 12</td><td>DB 17</td><td>DB 16</td><td>DB 15</td><td>DB 14</td><td>DB 13</td><td>DB 12</td> <td>DB 17</td><td>DB 16</td><td>DB 15</td><td>DB 14</td><td>DB 13</td><td>DB 12</td> </tr> <tr> <td>RGB data</td> <td>R5</td><td>R4</td><td>R3</td><td>R2</td><td>R1</td><td>R0</td><td>G5</td><td>G4</td><td>G3</td><td>G2</td><td>G1</td><td>G0</td><td>B5</td><td>B4</td><td>B3</td><td>B2</td><td>B1</td><td>B0</td> </tr> </table>	first transfer	second transfer						third transfer						GRAM data	DB 17	DB 16	DB 15	DB 14	DB 13	DB 12	DB 17	DB 16	DB 15	DB 14	DB 13	DB 12	DB 17	DB 16	DB 15	DB 14	DB 13	DB 12	RGB data	R5	R4	R3	R2	R1	R0	G5	G4	G3	G2	G1	G0	B5	B4	B3	B2	B1	B0	
first transfer	second transfer						third transfer																																																
GRAM data	DB 17	DB 16	DB 15	DB 14	DB 13	DB 12	DB 17	DB 16	DB 15	DB 14	DB 13	DB 12	DB 17	DB 16	DB 15	DB 14	DB 13	DB 12																																					
RGB data	R5	R4	R3	R2	R1	R0	G5	G4	G3	G2	G1	G0	B5	B4	B3	B2	B1	B0																																					

**Product Specification**

**3-4. SIGNAL TIMING SPECIFICATIONS**

**Table 3.10 16-bit interface mode**

Item		Symbol	Unit	Min	Typ	Max
Bus cycle time	Write	tCYCW	ns	120	-	-
	Read	tCYCR		400	-	-
Write "Low" level pulse width	Write	PWLW	ns	40	-	-
Read "Low" level pulse width	Read	PWLR		200	-	-
Read "High" level pulse width	Write	PWHW	ns	50	-	-
Write "High" level pulse width	Read	PWHR		200	-	-
Write/Read rise/fall time		twRr,twRf	ns	-	-	25
Setup time	Write (RS~CS*,WR*)	tAS	ns	0	-	-
	Read (RS~CS*,RD*)			10	-	-
Address hold time		tAH	ns	2	-	-
Write data setup time		tDSW	ns	25	-	-
Write data delay time		tH	ns	5	-	-
Read data delay time		tDDR	ns	-	-	150
Read data hold time		tDHR	ns	5	-	-

**Table 3.11 8-bit interface mode**

Item		Symbol	Unit	Min	Typ	Max
Bus cycle time	Write	tCYCW	ns	70	-	-
	Read	tCYCR		400	-	-
Write "Low" level pulse width	Write	PWLW	ns	40	-	-
Read "Low" level pulse width	Read	PWLR		200	-	-
Read "High" level pulse width	Write	PWHW	ns	30	-	-
Write "High" level pulse width	Read	PWHR		200	-	-
Write/Read rise/fall time		twRr,twRf	ns	-	-	25
Setup time	Write (RS~CS*,WR*)	tAS	ns	0	-	-
	Read (RS~CS*,RD*)			10	-	-
Address hold time		tAH	ns	2	-	-
Write data setup time		tDSW	ns	25	-	-
Write data delay time		tH	ns	5	-	-
Read data delay time		tDDR	ns	-	-	150
Read data hold time		tDHR	ns	5	-	-

Notes:

1. Normal Write Mode

Product Specification

3-5. SIGNAL TIMING WAVEFORMS

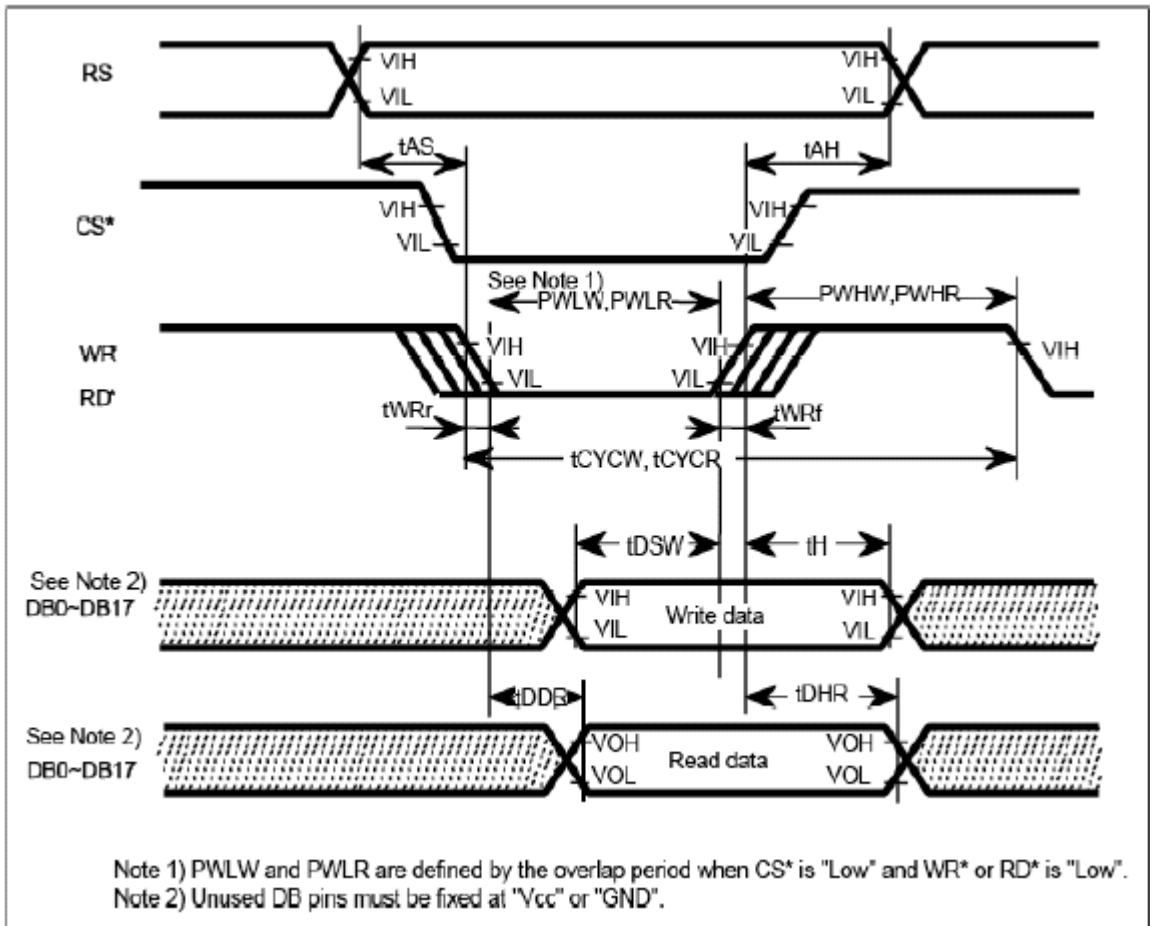

Fig 3.1 Timing Characteristics

**Product Specification**

**3-6. COLOR INPUT DATA REFERENCE**

Display Colors		Data Signal																	
		R 5	R 4	R 3	R 2	R 1	R 0	G 5	G 4	G 3	G 2	G 1	G 0	B 5	B 4	B 3	B 2	B 1	B 0
Basic Color	Black	0	0	0	0	0	0	0	0	0	0	0	0	0	0	0	0	0	0
	Blue	0	0	0	0	0	0	0	0	0	0	0	0	1	1	1	1	1	1
	Green	0	0	0	0	0	0	1	1	1	1	1	1	0	0	0	0	0	0
	Cyan	0	0	0	0	0	0	1	1	1	1	1	1	1	1	1	1	1	1
	Red	1	1	1	1	1	1	0	0	0	0	0	0	0	0	0	0	0	0
	Magenta	1	1	1	1	1	1	0	0	0	0	0	0	1	1	1	1	1	1
	Yellow	1	1	1	1	1	1	1	1	1	1	1	1	0	0	0	0	0	0
	White	1	1	1	1	1	1	1	1	1	1	1	1	1	1	1	1	1	1
Red Gray Scale	Black	0	0	0	0	0	0	0	0	0	0	0	0	0	0	0	0	0	0
	Darker	0	0	0	0	0	1	0	0	0	0	0	0	0	0	0	0	0	0
	↕	0	0	0	0	1	0	0	0	0	0	0	0	0	0	0	0	0	0
	↕	•	•	•	•	•	•	•	•	•	•	•	•	•	•	•	•	•	•
	↕	1	1	1	1	0	1	0	0	0	0	0	0	0	0	0	0	0	0
	Brighter	1	1	1	1	1	0	0	0	0	0	0	0	0	0	0	0	0	0
Red	1	1	1	1	1	1	0	0	0	0	0	0	0	0	0	0	0	0	
Green Gray Scale	Black	0	0	0	0	0	0	0	0	0	0	0	0	0	0	0	0	0	0
	Darker	0	0	0	0	0	0	0	0	0	0	1	0	0	0	0	0	0	0
	↕	0	0	0	0	0	0	0	0	0	1	0	0	0	0	0	0	0	0
	↕	•	•	•	•	•	•	•	•	•	•	•	•	•	•	•	•	•	•
	↕	0	0	0	0	0	0	1	1	1	1	0	1	0	0	0	0	0	0
	Brighter	0	0	0	0	0	0	1	1	1	1	1	0	0	0	0	0	0	0
Green	0	0	0	0	0	0	1	1	1	1	1	1	0	0	0	0	0	0	
Blue Gray Scale	Black	0	0	0	0	0	0	0	0	0	0	0	0	0	0	0	0	0	0
	Darker	0	0	0	0	0	0	0	0	0	0	0	0	0	0	0	0	0	1
	↕	0	0	0	0	0	0	0	0	0	0	0	0	0	0	0	0	1	0
	↕	•	•	•	•	•	•	•	•	•	•	•	•	•	•	•	•	•	•
	↕	0	0	0	0	0	0	0	0	0	0	0	0	1	1	1	1	0	1
	Brighter	0	0	0	0	0	0	0	0	0	0	0	0	1	1	1	1	1	0
Blue	0	0	0	0	0	0	0	0	0	0	0	0	1	1	1	1	1	1	

**Product Specification**
**4. OPTICAL CHARACTERISTICS**

Parameter	Symbol	Condition	Min.	Typ.	Max.	Unit	Remarks
Viewing angle range	$\Theta$ UP	CR $\geq$ 10		15		°(degree)	Note 3
	$\Theta$ DOWN			35		°(degree)	Note 3
	$\Theta$ LEFT			45		°(degree)	Note 3
	$\Theta$ RIGHT			45		°(degree)	Note 3
Contrast ratio	CR	Optimal		350		--	Note 2
Brightness	Y	Optimal	200				Note 6
Brightness Uniformity	Y	Optimal	75			%	Note 5
Response time	$\tau_f + \tau_r$	$\Theta = 0^\circ$ $T_a = 25^\circ\text{C}$			25	Ms	Note 4
Color Gamut	NTSC			47		%	

1. Optical Test Equipment & method refer to Note1.

**Product Specification**

[Note 1] Optical Test Equipment Setup

Optical characteristics are determined after the unit has been 'ON' and stable for approximately 30 minutes in a dark environment at 25°C. The values specified are at an approximate distance 50cm from the LCD surface. And back light LED current 20mA/1EA

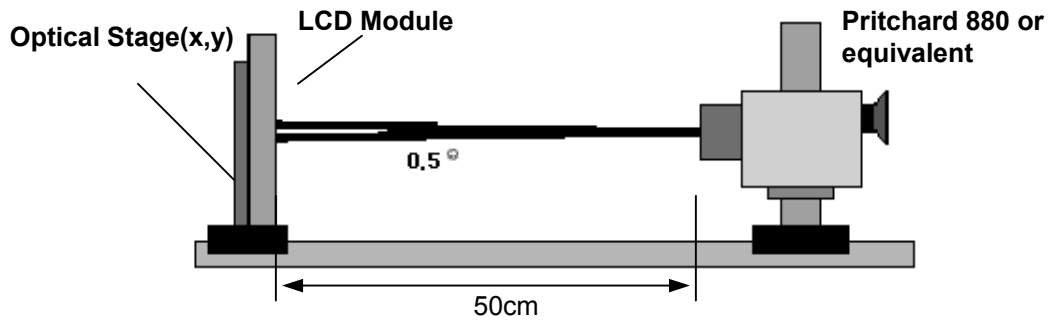

**Fig 4.1 Optical Characteristic Measurement Equipment and Method**

**Product Specification**

[Note 2]

Contrast ratio is defined as follows ;

$$\text{Contrast Ratio(CR)} = \frac{\text{Photo detector output with LCD being "white"}}{\text{Photo detector output with LCD being "black"}}$$

[Note 3]

Viewing angle range is defined as follows;

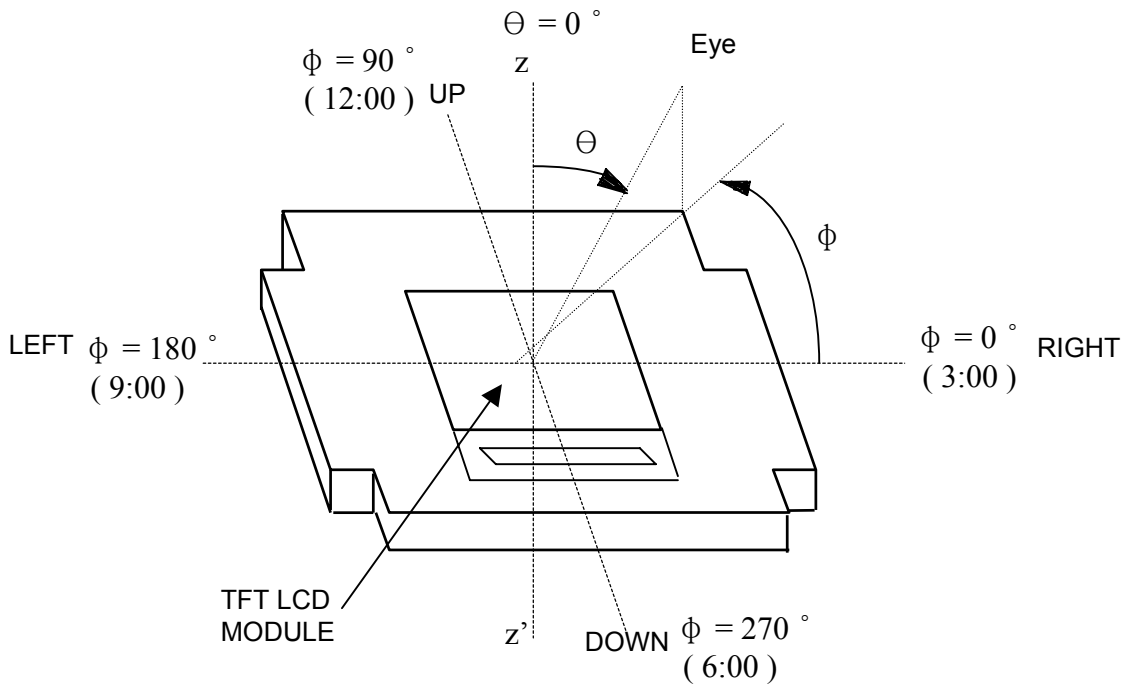

**Fig 4.2 Viewing Angle Definitions**



**Product Specification**

[Note 4]

Response time is obtained by measuring the transition time of photo detector output, when input signals are applied so as to make the area “black” to and from “white”.

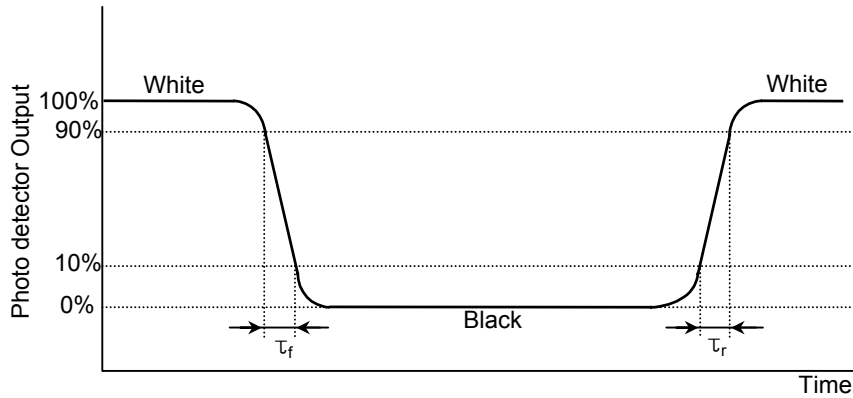
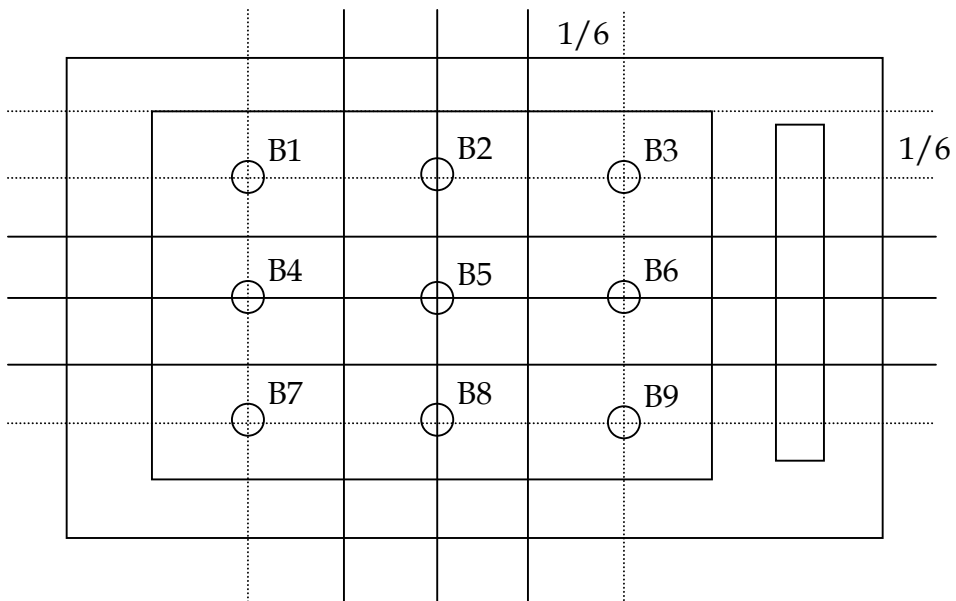

**Fig 4.3 Response Time Definition**

[Note 5]

The brightness measurement is taken at point B5.

$$\text{Brightness Uniformity} = \frac{\text{Minimum Photo detector output for B1-B9 with all pixels white}}{\text{Maximum Photo detector output for B1-B9 with all pixels white}} \times 100$$



**Fig 4.4 Brightness measurement points**

**Product Specification****5. MECHANICAL CHARACTERISTICS**

The contents provide general mechanical characteristics for the model LH220J01.  
In addition the figures in the next page are detailed mechanical drawing of the LCD.

<b>DIMENSION</b>	<b>MIN</b>	<b>TYP</b>	<b>MAX</b>	<b>UNIT</b>
HORIZONTAL (H)	40.7	40.9	41.1	MM
VERTICAL (V)	54.16	54.36	54.56	MM
DEPTH (D)	1.85	2	2.15	MM

**Product Specification**

**[ Outline Dimension ]**

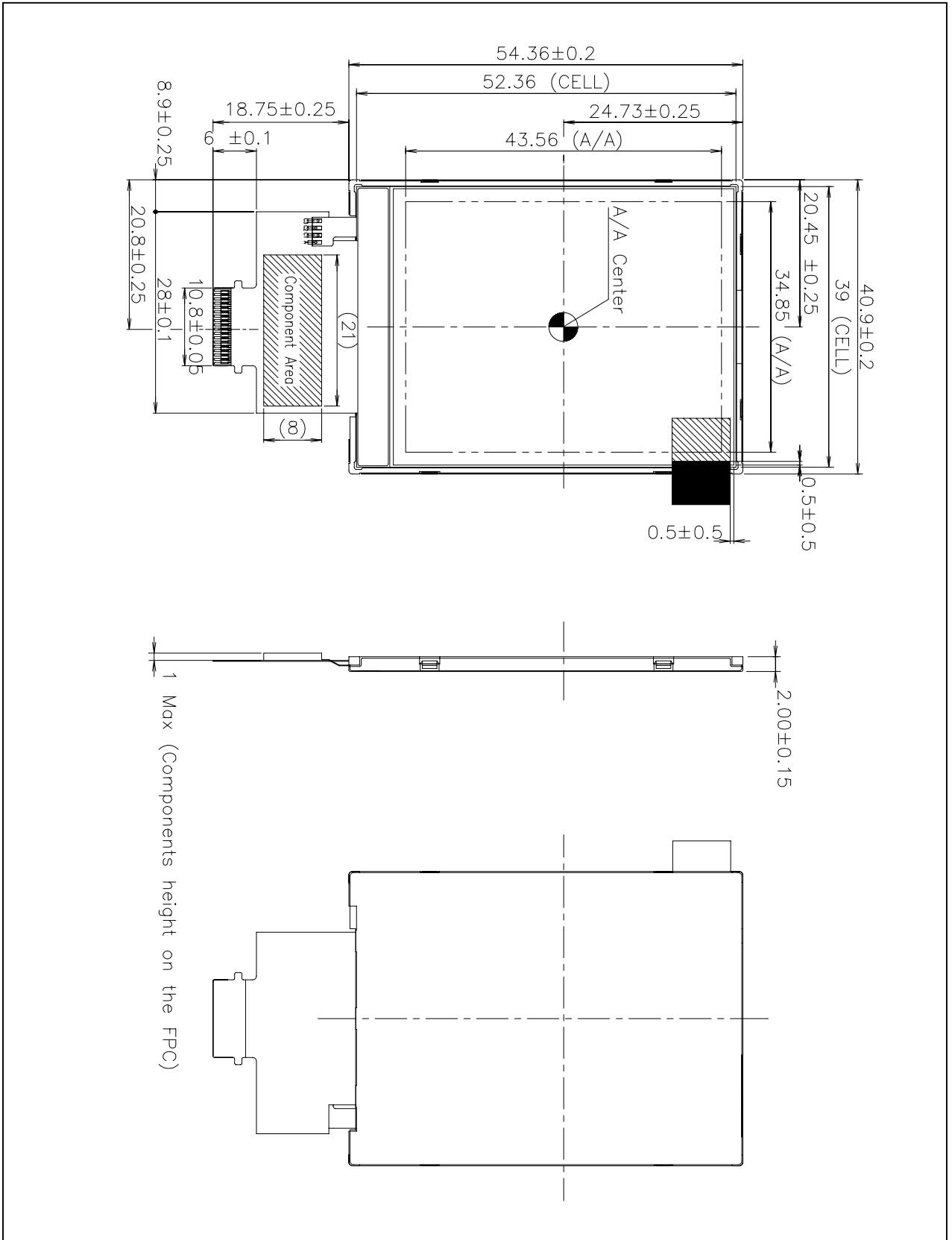

Product Specification

[ Circuit of FPC ]

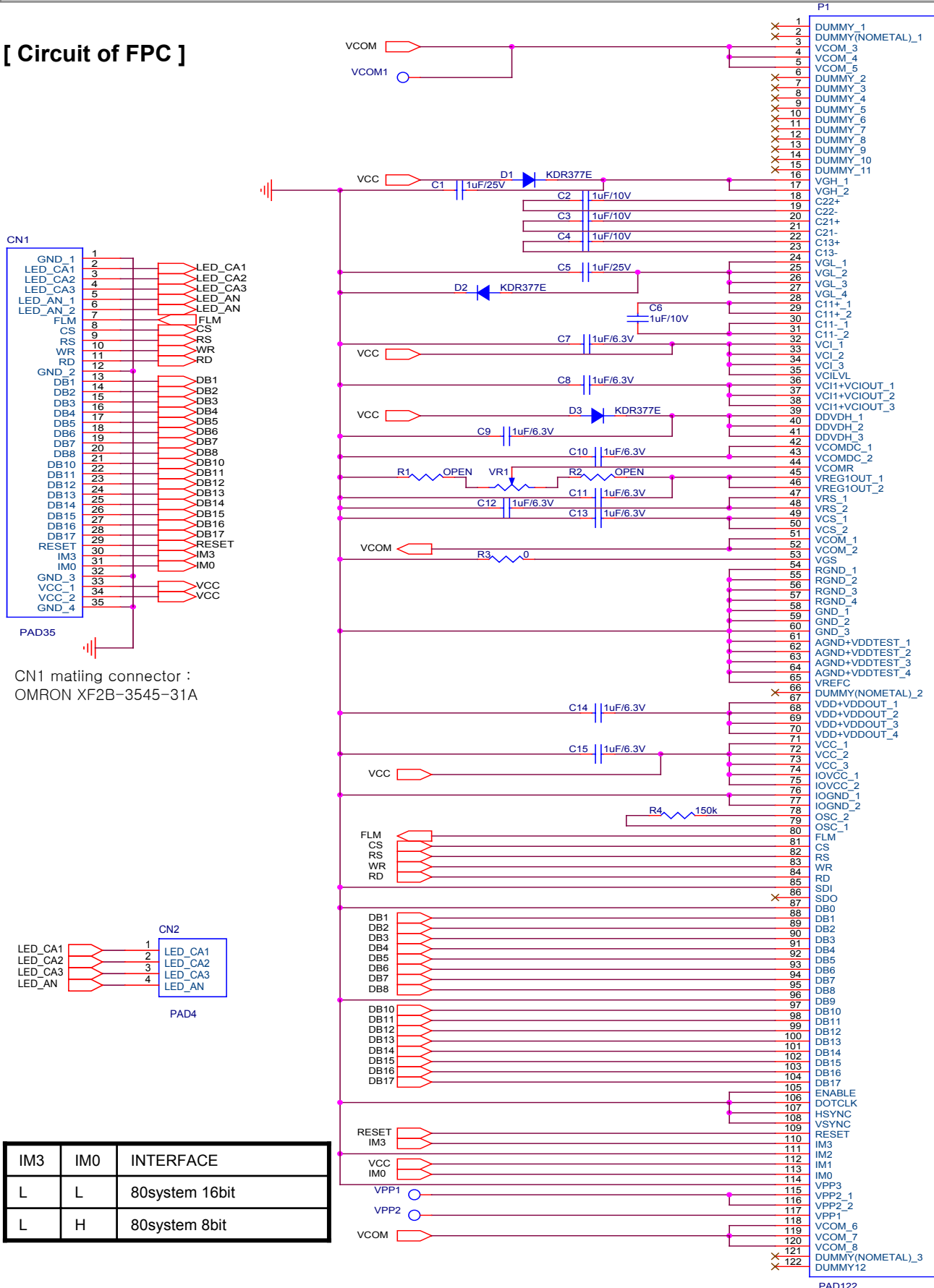

**Product Specification**

**[ Operation Flow Chart ]**

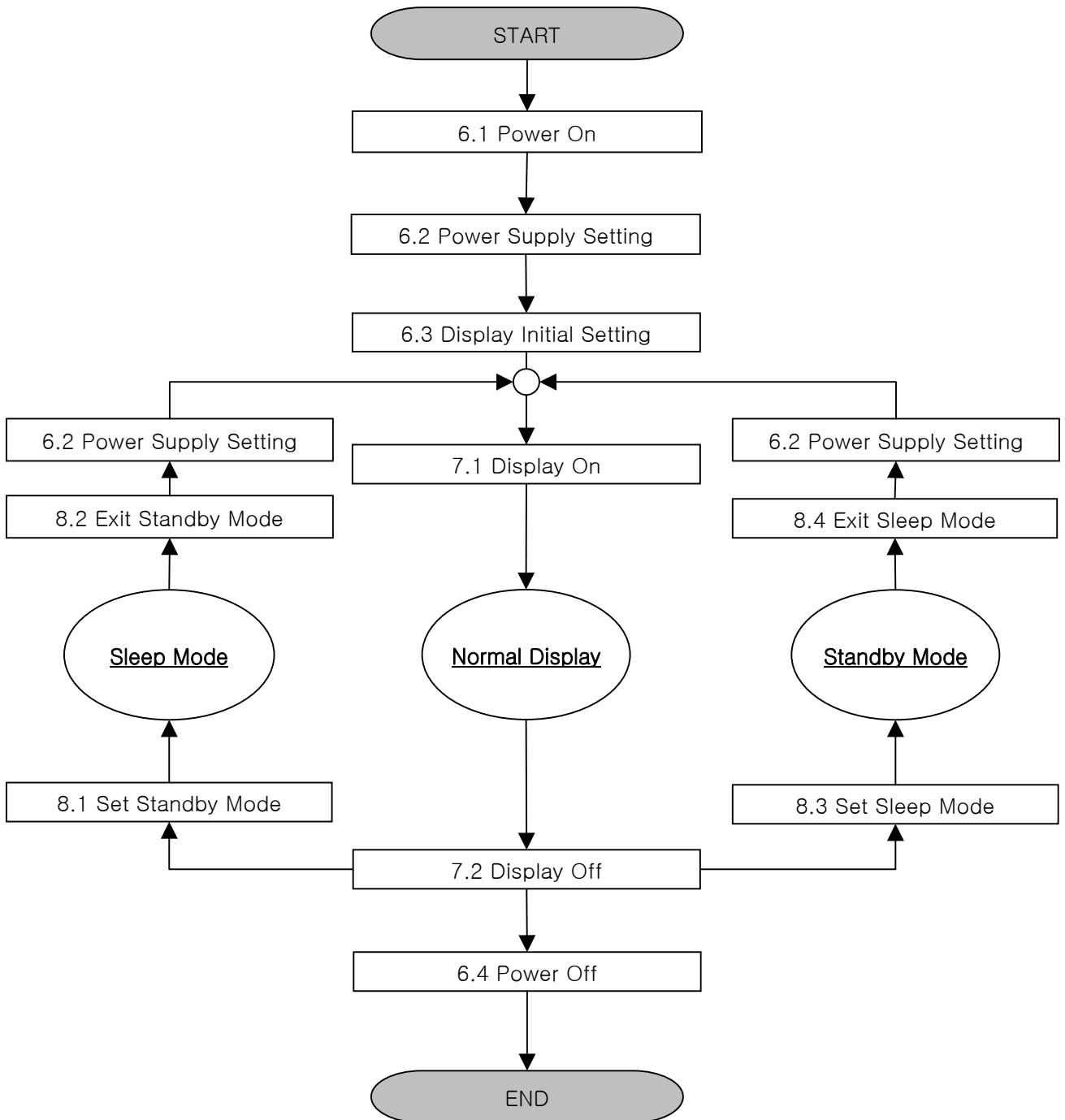

**Product Specification**

**6. POWER SUPPLY SEQUENCE**

**Table 6.1 Power ON Sequence**

Step	Register Setting		Operation	Remarks
	Register	Data		
1	VCC/RVCC→IOVCC→Vci or VCC/RVCC, IOVCC, Vci Simultaneously			Power On
2	R61503B Hard Reset			
3	0007	0000	DTE=0, D1-0=00, GON=0, VON=0	
4	0012	0000	PON=0	
5	2ms Delay or more			
6	RS=0, DB=16'h0000 (Transfer synchronization)			
7	RS=0, DB=16'h0000 (Transfer synchronization)			
8	RS=0, DB=16'h0000 (Transfer synchronization)			
9	RS=0, DB=16'h0000 (Transfer synchronization)			
10	00A4	0001	CALB=1	
11	10ms Delay or more			

**Table 6.2 Power Supply Setting**

Step	Register Setting		Operation	Remarks
	Register	Data		
1	0007	0001	D1-0=01	
2	0018	0001	PSE=1	
3	0010	11B0	Power supply user setting(1)	
4	0011	0111	Power supply user setting(2)	
5	0012	1112	Power supply user setting(3)	
6	0013	8e07	Power supply user setting(4)	
7	0014	8000	Power supply user setting(5)	
8	0012	0132	Power supply user setting(6)	

**Product Specification**

**Table 6.3 Display Initial Setting**

Step	Register Setting		Operation	Remarks
	Register	Data		
1	10ms Delay or more			
2	0001	0100	Driver output control(1)	
3	0002	0700	Liquid crystal drive waveform	
4	0003	1030	Entry mode	
5	0004	0000	Resize control	
6	0008	0708	Display control(1)	
7	0009	0000	Display control(2)	
8	0020	0000	RAM address set(1)	
9	0021	0000	RAM address set(2)	
10	0030	0400	Gamma setting(1)	
11	0031	0507	Gamma setting(2)	
12	0032	0006	Gamma setting(3)	
13	0033	0007	Gamma setting(4)	
14	0034	0207	Gamma setting(5)	
15	0035	0100	Gamma setting(6)	
16	0036	0704	Gamma setting(7)	
17	0037	0007	Gamma setting(8)	
18	0038	1F1F	Gamma setting(9)	
19	0039	0900	Gamma setting(10)	
20	003A	0712	Gamma setting(11)	
21	0050	0000	Horizontal RAM address start	
22	0051	00AF	Horizontal RAM address end	
23	0052	0000	Vertical RAM address start	
24	0053	00DB	Vertical RAM address end	
25	0070	1B00	Driver output control(2)	
26	0071	0001	Base image control	
27	0090	0004	Panel interface control(1)	
28	0091	0100	Panel interface control(2)	
29	0092	0002	Panel interface control(3)	
30	0098	0002	Source driver output control(1)	
31	0099	060D	Source driver output control(2)	
32	009A	060D	Source driver output control(3)	

**Product Specification**

**Table 6.4 Power OFF Sequence**

Step	Register Setting		Operation	Remarks
	Register	Data		
1	0010	0080	AP1-0=00, SAP=0	
2	0011	0060	DC2-0=110	
3	0012	0000	PON=0	
4	0013	0000	VCOMG=0	
5	20ms Delay (1frame periods or more)			
6	0010	0000	APE=0	
7	Vci→IOVCC→VCC/RVCCi or VCC/RVCC, IOVCC, Vci Simultaneously			Power Off



**Product Specification**

**7. DISPLAY SEQUENCE**

**Table 7.1 Display On Sequence**

Step	Register Setting		Operation	Remarks
	Register	Data		
1	0007	0001	GON=0, DTE=0, D1-0=01	
2	40ms Delay (2frame periods or more)			
3	0007	0021	GON=1, DTE=0, D1-0=01	
4	10ms Delay (8H periods or more)			
5	0007	0233	BESEE=1,GON=1, DTE=1, D1-0=11	

**Table7.2 Display OFF Sequence**

Step	Register Setting		Operation	Remarks
	Register	Data		
1	0007	0002	GON=0, DTE=0, D1-0=10	
2	0012	0132	VON=1	
3	40ms Delay (2frame periods or more)			
4	0007	0000	GON=0, DTE=0, D1-0=00	
5	0010	0080	AP1-0=00, SAP=0	
6	0011	0060	DC2-0=110	
7	0012	0000	PON=0	
8	0013	0000	VCOMG=0	
9	20ms Delay (1frame periods or more)			
10	0010	0000	APE=0	

**Product Specification**

**8. STANDBY & SLEEP SEQUENCE**

**Table 8.1 Standby Mode Set Sequence**

Step	Register Setting		Operation	Remarks
	Register	Data		
1	0010	0001	STB=1	

**Table 8.2 Standby Mode Exit Sequence**

Step	Register Setting		Operation	Remarks
	Register	Data		
1	0000	0001	Start oscillation	
2	1ms Delay or more			
3	0010	0000	STB=0	

**Table 8.3 Sleep Mode Set Sequence**

Step	Register Setting		Operation	Remarks
	Register	Data		
1	0010	0002	SLP=1	

**Table 8.4 Sleep Mode Exit Sequence**

Step	Register Setting		Operation	Remarks
	Register	Data		
1	0010	0000	SLP=0	
2	10ms Delay (1clock or more)			

**Product Specification**

**9. RELIABILITY TEST**

**T. B. D**

**Product Specification**

**10. INTERNATIONAL STANDARDS**

**T. B. D**

**Product Specification**

**11. PACKING**

**11-1. DESIGNATION OF LOT MARK**

a) Lot Mark

A	B	C	D	E	F	G	H	I	J	K	L	M
---	---	---	---	---	---	---	---	---	---	---	---	---

A,B,C : SIZE(INCH)

E : MONTH

G : ASSEMBLY CODE

D : YEAR

F : FACTORY CODE

H ~ M : SERIAL NO.

Note

1. YEAR

Year	2001	2002	2003	2004	2005	2006	2007	2008	2009	2010
Mark	1	2	3	4	5	6	7	8	9	0

2. MONTH

Month	Jan	Feb	Mar	Apr	May	Jun	Jul	Aug	Sep	Oct	Nov	Dec
Mark	1	2	3	4	5	6	7	8	9	A	B	C

3. FACTORY CODE

Factory Code	LPL Gumi	LPL Nanjing	HEESUNG	LG Innotek
Mark	K	C	D	T

4. SERIAL NO.

Mark	100001~199999, 200001~299999, 300001~399999, ....., A00001~A99999, ....., Z00001~Z99999
------	---

b) Location of Lot Mark

Serial NO. is printed on the back surface of LCM

This is subject to change without prior notice.

**Product Specification**

**11-2. PACKING FORM**

- a) Package quantity in one box : 400 pcs
- b) Box Size : 475mm X 348mm X 210mm
- c) 1Box = 20(Full tray) + 1 (dummy / top tray) = 21 tray

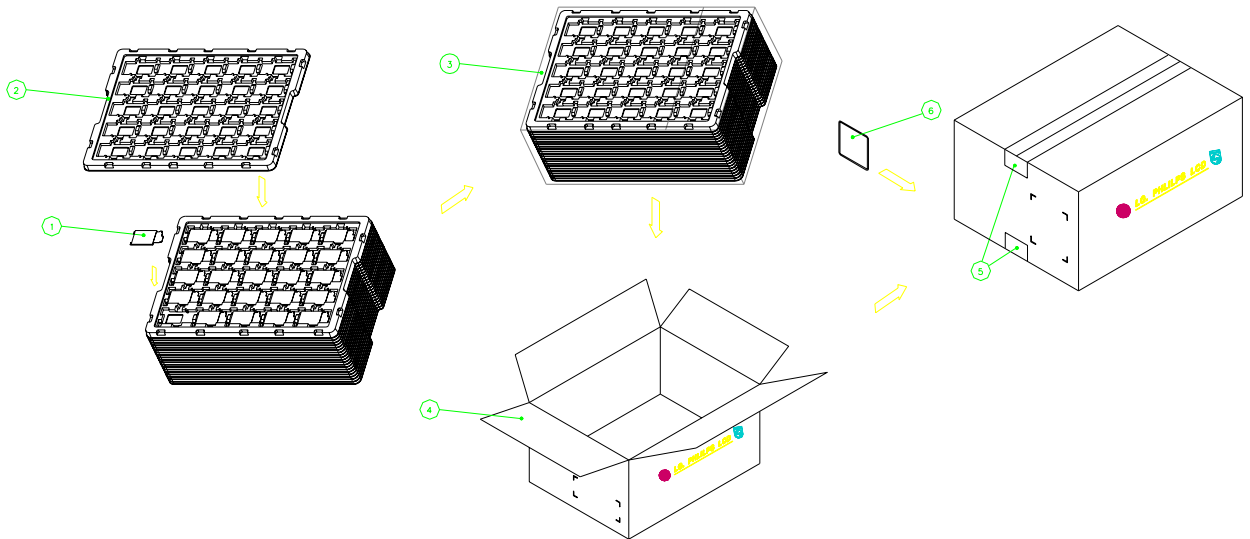

NO.	Description	Material
1	Module	
2	Packing, tray	PET(0.8t)
3	Bag	PE 560x830
4	Box	SWR4 465x338x192
5	Tape	OPP 70MMx300m
6	Label	Art Paper 100x100

## Product Specification

### 12. PRECAUTIONS

Please pay attention to the following when you use this TFT LCD module.

#### 12-1. ASSEMBLY PRECAUTIONS

- (1) Please attach a transparent protective plate to the surface in order to protect the polarizer.  
Transparent protective plate should have sufficient strength in order to resist external force.
- (2) You should adopt radiation structure to satisfy the temperature specification.
- (3) Acetic acid type and chlorine type materials for the cover case are not desirable because the former generates corrosive gas of attacking the polarizer at high temperature and the latter causes circuit break by electro-chemical reaction.
- (4) Do not touch, push or rub the exposed polarizers with glass, tweezers or anything harder than HB pencil lead. And please do not rub with dust clothes with chemical treatment.  
Do not touch the surface of polarizer for bare hand or greasy cloth. (Some cosmetics deteriorate the polarizer.)
- (5) When the surface becomes dusty, please wipe gently with absorbent cotton or other soft materials like chamois soaks with petroleum benzine. Normal-hexane is recommended for cleaning the adhesives used to attach front / rear polarizers. Do not use acetone, toluene and alcohol because they cause chemical damage to the polarizer.
- (6) Wipe off saliva or water drops as soon as possible. Their long time contact with polarizer causes deformations and color fading.
- (7) Do not open the case because inside circuits do not have sufficient strength.
- (8) The metal case of a module should be contacted to electrical ground of your system.

#### 12-2. OPERATING PRECAUTIONS

- (1) The spike noise causes the mis-operation of circuits. It should be lower than following voltage :  
 $V = \pm 200\text{mV}$  (Over and under shoot voltage)
- (2) Response time depends on the temperature. (In lower temperature, it becomes longer.)
- (3) Brightness depends on the temperature. (In lower temperature, it becomes lower.)  
And in lower temperature, response time (required time that brightness is stable after turned on) becomes longer.
- (4) Be careful for condensation at sudden temperature change. Condensation makes damage to polarizer or electrical contacted parts. And after fading condensation, smear or spot will occur.
- (5) When fixed patterns are displayed for a long time, remnant image is likely to occur.
- (6) Module has high frequency circuits. Sufficient suppression to the electromagnetic interference shall be done by system manufacturers. Grounding and shielding methods may be important to minimized the interference.

## Product Specification

### 12-3. ELECTROSTATIC DISCHARGE CONTROL

Since a module is composed of electronic circuits, it is not strong to electrostatic discharge. Make certain that treatment persons are connected to ground through wrist band etc. And don't touch interface pin directly.

### 12-4. PRECAUTIONS FOR STRONG LIGHT EXPOSURE

Strong light exposure causes degradation of polarizer and color filter.

### 12-5. STORAGE

When storing modules as spares for a long time, the following precautions are necessary.

- (1) Store them in a dark place. Do not expose the module to sunlight or fluorescent light. Keep the temperature between 5°C and 35°C at normal humidity.
- (2) The polarizer surface should not come in contact with any other object.  
It is recommended that they be stored in the container in which they were shipped.

### 12-6. HANDLING PRECAUTIONS FOR PROTECTION FILM

- (1) When the protection film is peeled off, static electricity is generated between the film and polarizer.  
This should be peeled off slowly and carefully by people who are electrically grounded and with well ion-blown equipment or in such a condition, etc.
- (2) The protection film is attached to the polarizer with a small amount of glue. If some stress is applied to rub the protection film against the polarizer during the time you peel off the film, the glue is apt to remain on the polarizer.  
Please carefully peel off the protection film without rubbing it against the polarizer.
- (3) When the module with protection film attached is stored for a long time, sometimes there remains a very small amount of glue still on the polarizer after the protection film is peeled off.
- (4) You can remove the glue easily. When the glue remains on the polarizer surface or its vestige is recognized, please wipe them off with absorbent cotton waste or other soft material like chamois soaked with normal-hexane.