

Product General Specification

1. General Description

The LM151X1 LCD is a Color Active Matrix Liquid Crystal Display with an integral Cold Cathode Fluorescent Tube(CCFT) back light system. The matrix employs α -Si Thin Film Transistor as the active element. It is a transmissive type display operating in the normally white mode. This TFT-LCD has a 15.1 inch diagonally measured active display area with XGA resolution(768 vertical by 1024 horizontal pixel array). Each pixel is divided into Red, Green and Blue sub-pixels or dots which are arranged in vertical stripes. Gray scale or the brightness of the sub-pixel color is determined with a 8-bit gray scale signal for each dot, thus, presenting a palette of more than 16,777,216 colors.

LM151X1 has been designed to apply the interface method that enables low power, high speed low EMI. Panellink must be used as a LVDS(Low Voltage Differential Signaling) chip.

The LM151X1 LCD is intended to support applications where high brightness, wide viewing angle, high color saturation, and high color depth are very important. In combination with the vertical arrangement of the sub-pixels, the LM151X1-D2MN characteristics provide an excellent flat panel display for office automation products such as monitors.

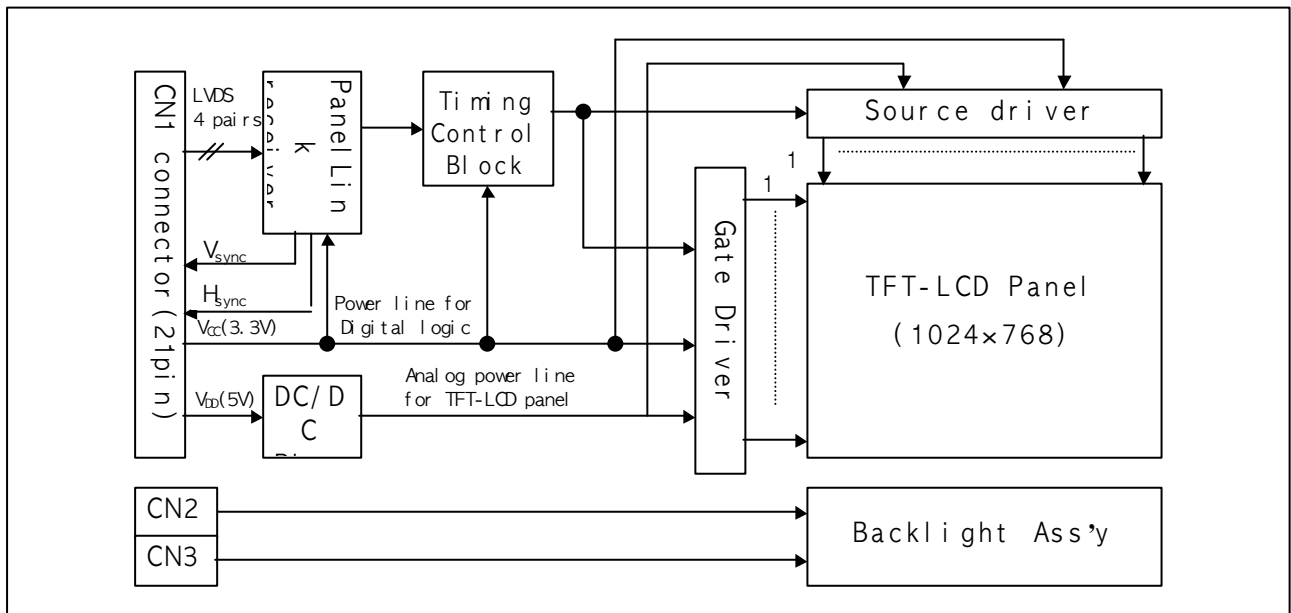

General Display Characteristics

The following are general features of the model LM151X1 LCD;

- Active display area 15.1 inches(38cm) diagonal
- Outside dimensions 352.6w * 264.6h * 16.0t(typ)mm(Without Inverter)
- Pixel pitch 0.30 mm × 0.30 mm
- Pixel format 1024 horiz. By 768 vert. pixels
- RGB vertical stripe arrangement
- Color depth 8bit, 16,777,216 colors
- Display operating mode transmissive mode, normally white
- Surface treatments hard coating(3H),
 anti-glare treatment of the front polarizer

Product General Specification
2. Electrical Specifications
2-1 Electrical Characteristics

The LM151X1 requires three power inputs. Two inputs are employed to power the LCD electronics and to drive the voltages to drive the TFT array and liquid crystal. And the third input which powers the backlight CCFL, is typically generated by an inverter. The inverter is an external unit to the LCD.

Table1 ELECTRICAL CHARACTERISTICS:

Parameter	Symbol	Values			Units	Notes
		Min.	Typ.	Max.		
MODULE:						
Power Supply Input Voltage	V _{DD}	4.75	5.0	5.25	V _{DC}	1
	V _{CC}	3.15	3.3	3.45	V _{DC}	
Power Supply Input Current	I _{VDD}	-	360	500	mA	2
	I _{VCC}	-	230	300	mA	
Power Supply Kick-Off Current	I _{VDD}	-	-	1.2	A	3
	I _{VCC}	-	-	0.6	A	
BACK LIGHT						
Back light Input voltage	V _{BL}	685	585	570	V _{RMS}	
Backlight Input Current	I _{BL}	3.0	8.0	9.0	mA	4
Lamp Kick-Off Voltage		-	-	880	V _{RMS}	At 25±2°C
		-	-	1145	V _{RMS}	At 0±2°C
		1290	-	-	V _{RMS}	5
		1660	-	-	V _{RMS}	At 25±2°C
						6
Operating Frequency	F _{BL}	30	50	80	KHz	
Life time		25,000	40,000	-	hours	7

- Notes: 1. V_{DD} input is the analog power supply for the TFT array and liquid crystal, and V_{CC} input is the digital logic power supply for the LCD electronics.
2. The input current shall be measured at V_{DD} of 5.0Vdc at 25°C, refresh rate of 60Hz, and clock frequency of 65MHz under 9 gray pattern.
3. Power supply kick off current means power supply input current at the moment of LCM power on. This current is higher than the current at the normal operating condition and it lasts for 50~100ms.
4. The backlight input current shall be measured at the ground cable and does not include loss of external inverter.
5. Voltages at both ends of the lamp.
6. Voltages at secondary side of transformer using the balancing capacitor, 22pF in inverter. These voltages can be changed with customer's own design of inverter.
7. The life time is defined as the time at which brightness of lamp is 50% compare to that of initial value at the typical lamp current on condition of continuous operating at 25±2°C.

Product General Specification
2-2 Interface Connections

This LCD employs three interface connections, a 21 pin connector is used for the module electronics and two connectors, a three pin connector, are used for the integral backlight system.

Interface chip as a transmitter, must be used Panellink ,part No. Si1100, designed by Silicon Image Inc. or equivalent.

The electronics interface connector is a model FI-WE21P-HF manufactured by JAE. The pin configuration for the connector is shown in the table below.

Table 2 MODULE CONNECTOR PIN CONFIGURATION

Pin	Symbol	Description	Notes
1	GND	System ground	see Note 1
2	V _{DD}	Analog power supply for TFT array and liquid crystal	+5.0V
3	V _{DD}	-	+5.0V
4	V _{DD}	-	+5.0V
5	GND	System ground	see Note 1
6	GND	System ground	see Note 1
7	GND	System ground	see Note 1
8	V _{CC}	Digital logic power supply	+3.3V
9	R2+	Plus signal of channel 2 (Panellink)	R0~R7,CLT2,DE, See Note 2
10	R2-	Minus signal of channel 2 (Panellink)	-
11	V _{CC}	Digital logic power supply	+3.3V
12	R1+	Plus signal of channel 1 (Panellink)	G0 ~ G7, CLT0, CLT1, See Note 2
13	R1-	Minus signal of channel 1 (Panellink)	-
14	V _{CC}	Digital logic power supply	+3.3V
15	R0+	Plus signal of channel 0 (Panellink)	B0 ~ B7, H _{sync} , V _{sync} ,See Note 2
16	R0-	Minus signal of channel 0 (Panellink)	-
17	H _{sync}	Output pin of H _{sync} signal for the customer's usage	see Note 3
18	RCL+	Plus signal of clock channel (Panellink)	Main Clock, See Note 2
19	RCL-	Minus signal of clock channel (Panellink)	-
20	V _{sync}	Output pin of V _{sync} signal for the customer's usage	see Note 3
21	NC	No Connection	

- Notes: 1. All GND(ground) pins should be connected to the LCD's metal frame.
 2. Refer to the data sheet of Panellink transmitter Si1100.
 3. Pins for DPMS. When V_{CC} is on, V_{sync} and H_{sync} are available. In case HSYNC output, sync width is always fixed about 1.1usec independent of HSYNC coming from VGA controller.



The backlight interface connector is a model BHR-03VS-1, manufactured by JST. The mating connector part number is SM02(8.0)B-BHS-1-TB or equivalent. The pin configuration for the connector is shown in the table below.

Table 3 BACKLIGHT CONNECTOR PIN CONFIGURATION

Pin	Symbol	Description	Notes
1	HV	Lamp power input	1
2	NC	No connect	
3	LV	Ground	2

- Notes: 1. The input power terminal is colored pink. Ground pin color is light pink.

Product General Specification

< Front View >

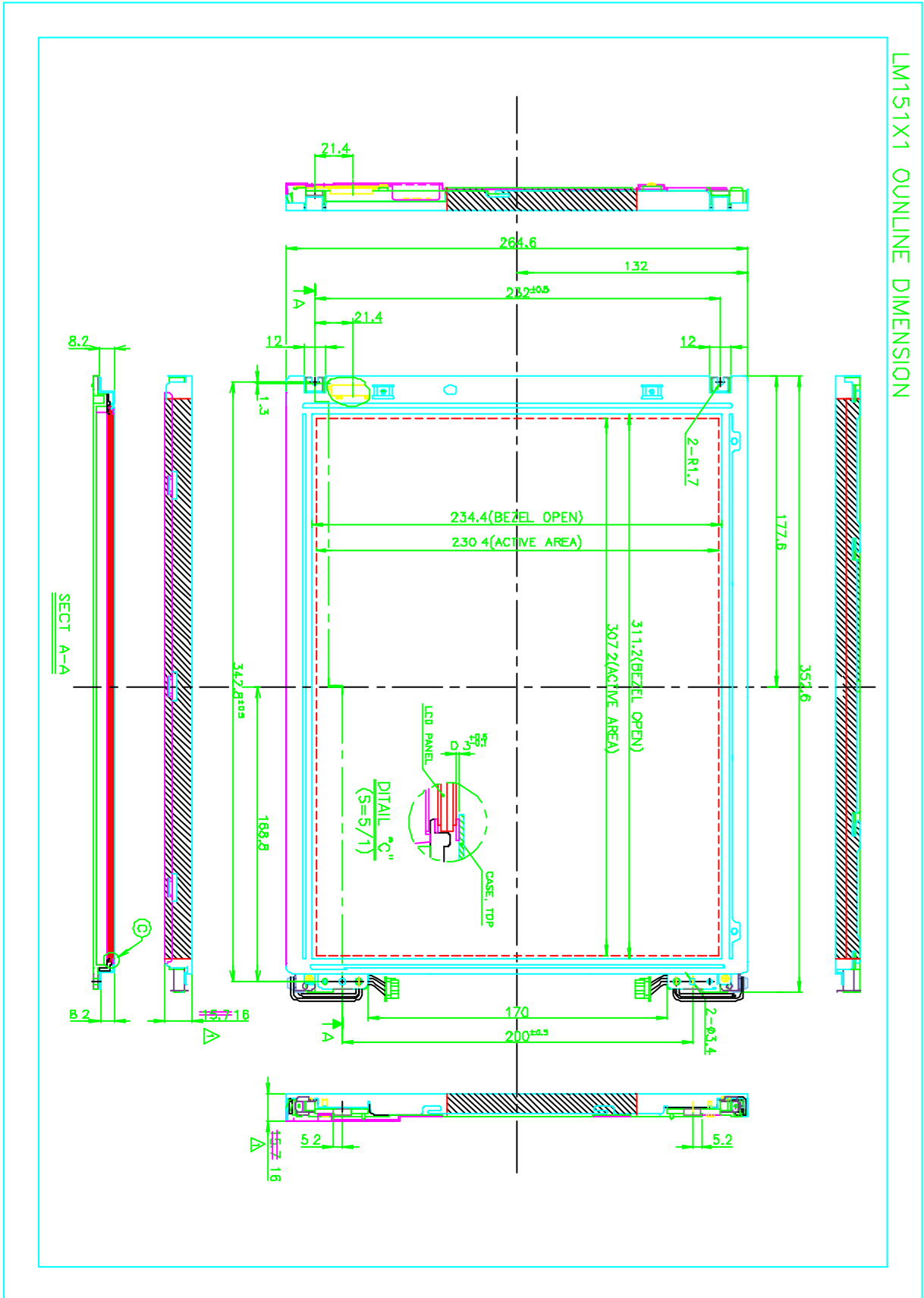

Product General Specification

< Rear View >

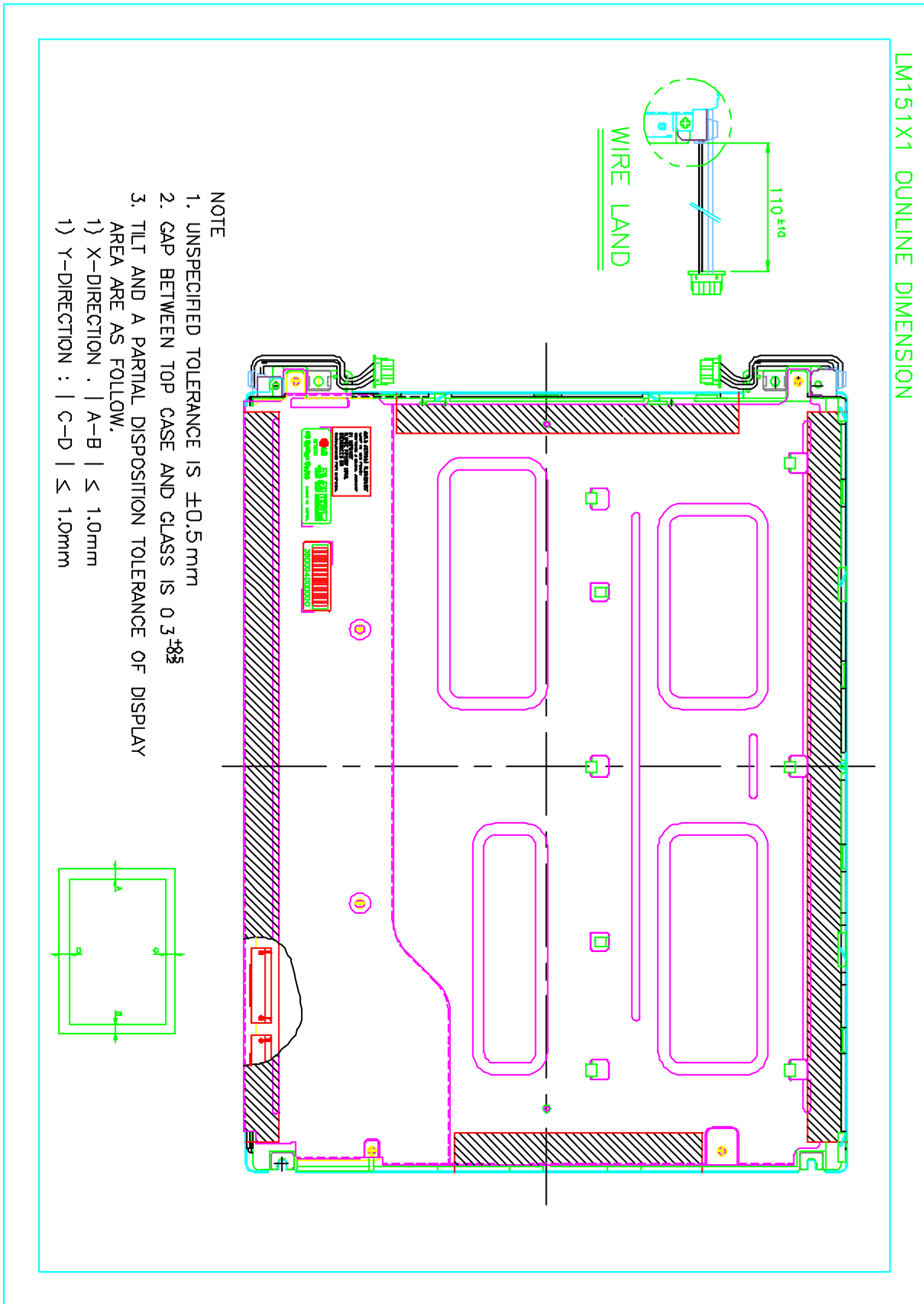

Product General Specification**3. PRECAUTIONS**

The LCD Products listed on this documents are not suitable for use of Military, Industry, Medical etc. system.

If customers intend to use these LCD products for above application, please contact our sales people in advance.