

**Product Specification**

**SPECIFICATION  
FOR  
APPROVAL**

- ( ) Preliminary Specification  
 (◆) Final Specification

Title	<b>17.0" SXGA TFT LCD</b>
-------	---------------------------

BUYER	
MODEL	

SUPPLIER	<b>LG.Philips LCD Co., Ltd.</b>
*MODEL	<b>LM170E01</b>
SUFFIX	<b>TLB3</b>

\*When you obtain standard approval,  
please use the above model name without suffix

SIGNATURE	DATE
/	_____
/	_____
/	_____

APPROVED BY	DATE
G.T. Kim / Manager	_____
<b>REVIEWED BY</b>	
Y.W.Lee / Manager	_____
<b>PREPARED BY</b>	
K.Y. Kwon / Engineer	_____

Please return 1 copy for your confirmation with your signature and comments.

**Product Engineering Dept.  
LG. Philips LCD Co., Ltd**

**Product Specification**

**CONTENTS**

NO.	ITEM	Page
-	COVER	1
-	CONTENTS	2
-	RECORD OF REVISIONS	3
1	GENERAL DESCRIPTION	4
2	ABSOLUTE MAXIMUM RATINGS	5
3	ELECTRICAL SPECIFICATIONS	6
3-1	ELECTRICAL CHARACTERISTICS	6
3-2	INTERFACE CONNECTIONS	8
3-3	SIGNAL TIMING SPECIFICATIONS	12
3-4	SIGNAL TIMING WAVEFORMS	13
3-5	COLOR INPUT DATA REFERANCE	14
3-6	POWER SEQUENCE	15
3-7	VCC POWER DIP CONDITION	16
4	OPTICAL SPECIFICATIONS	17
5	MECHANICAL CHARACTERISTICS	21
6	RELIABILITY	24
7	INTERNATIONAL STANDARDS	25
7-1	SAFETY	25
7-2	EMC	25
8	PACKING	26
8-1	DESIGNATION OF LOT MARK	26
8-2	PACKING FORM	26
9	PRECAUTIONS	27

**Product Specification**

**RECORD OF REVISIONS**

<b>Revision No</b>	<b>Date</b>	<b>Page</b>	<b>Description</b>
<b>Ver 1.0</b>	<b>Jan. 05, 2006</b>		<b>Final Specification</b>

**Product Specification**

**1. General Description**

The LM170E01-TLB3 is a Color Active Matrix Liquid Crystal Display with an integral Cold Cathode Fluorescent Lamp(CCFL) backlight system. The matrix employs a-Si Thin Film Transistor as the active element. It is a transmissive type display operating in the normally white mode. This TFT-LCD has a 17.0 inch diagonal measured active display area with SXGA resolution(1024 vertical by 1280 horizontal pixel array) Each pixel is divided into Red, Green and Blue sub-pixels or dots which are arranged in vertical stripes. Gray scale or the brightness of the sub-pixel color is determined with a 8-bit gray scale signal for each dot, thus, presenting a palette of more than 16.2M colors with FRC(Frame Rate Control).

The LM170E01-TLB3 has been designed to apply the interface method that enables low power, high speed, low EMI. FPD Link or compatible must be used as a LVDS(Low Voltage Differential Signaling) chip. The LM170E01-TLB3 is intended to support applications where thin thickness, wide viewing angle, low power are critical factors and graphic displays are important. In combination with the vertical arrangement of the sub-pixels, the LM170E01-TLB3 characteristics provide an excellent flat panel display for office automation products such as monitors.

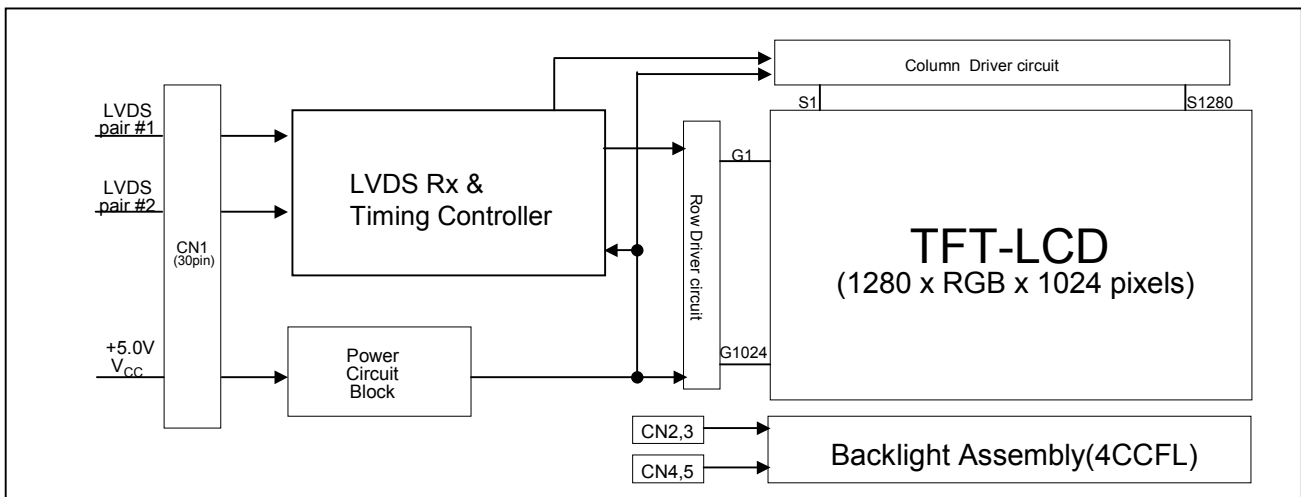

**Figure 1. Block diagram**

**General Features**

Active screen size	17.0 inch (43.27cm) diagonal
Outline Dimension	358.5(H) x 296.5(V) x 17.0(D) mm(Typ.)
Pixel Pitch	0.264 mm x 0.264 mm
Pixel Format	1280 horiz. by 1024 vert. Pixels. RGB stripe arrangement
Display Colors	16.2M colors
Luminance, white	300 cd/m <sup>2</sup> (Typ. Center 1 point)
Power Consumption	19.4 Watts(Typ.)
Weight	2150g (Typ.)
Display operating mode	Transmissive mode, normally white
Surface treatments	Hard coating (3H), Anti-glare treatment of the front polarizer

**Product Specification**

**2. Absolute maximum ratings**

The following are maximum values which, if exceeded, may cause faulty operation or damage to the unit.

**Table 1. Absolute Maximum Ratings**

Parameter	Symbol	Values		Units	Notes
		Min.	Max.		
Power Supply Input Voltage	$V_{CC}$	- 0.3	+ 5.5	$V_{dc}$	At 25 °C
Operating Temperature	$T_{OP}$	0	+ 50	°C	1
Storage Temperature	$T_{ST}$	- 20	+ 60	°C	1
Operating Ambient Humidity	$H_{OP}$	10	+ 90	%RH	1
Storage Humidity	$H_{ST}$	10	+ 90	%RH	1

Note : 1. Temperature and relative humidity range are shown in the figure below.  
 Wet bulb temperature should be 39 °C Max, and no condensation of water.

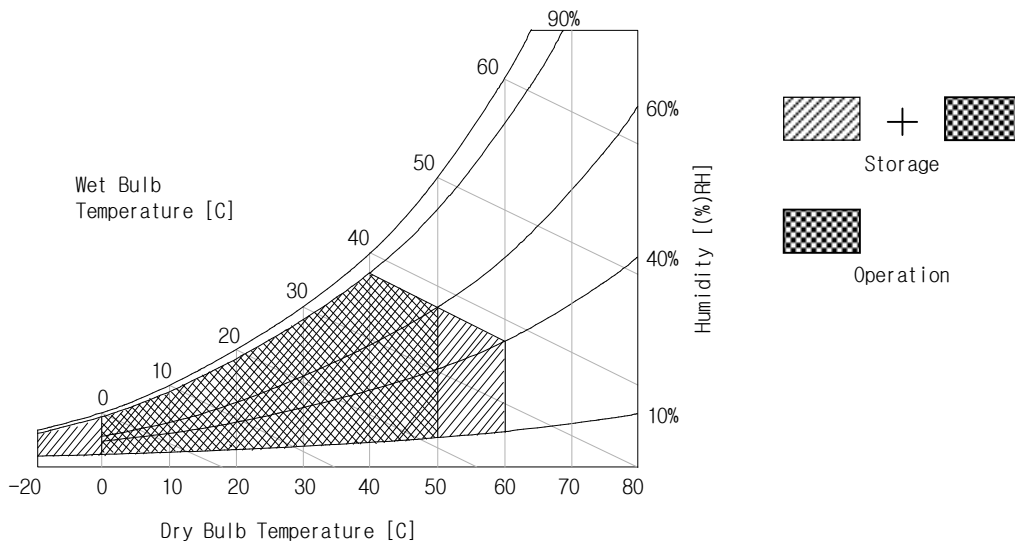

**Figure 2. Temperature and relative humidity**

**Product Specification**

**3. Electrical specifications**

**3-1. Electrical characteristics**

The LM170E01-TLB3 requires two power inputs. One is employed to power the LCD electronics and to drive the TFT array and liquid crystal. Another which powers the CCFL, is typically generated by an inverter. The inverter is an external unit to the LCD.

**Table 2. Electrical Characteristics**

Parameter	Symbol	Values			Units	Notes
		Min.	Typ.	Max.		
MODULE :						
Power Supply Input Voltage	$V_{CC}$	4.5	5.0	5.5	V	
Permissive Power Input Ripple	$V_{RF}$	-	-	0.1	V	
Power Supply Input Current	$I_{CC}$	-	0.50	0.58	A	1
Differential Impedance	$Z_m$	90	100	110	ohm	
Power Consumption	$P_C$	-	2.5	2.9	Watts	
Rush Current	$I_{RUSH}$	-	2.0	3.0	A	2
LAMP for each CCFL:						
Operating Voltage	$V_{BL}$	576 (@7.0mA)	650 (@6.5mA)	745 (@2.5mA)	$V_{RMS}$	3
Operating Current	$I_{BL}$	2.5	6.5	7.0	$mA_{RMS}$	
Established Starting Voltage	$V_{BS}$					4
at 25 °C		-	-	1000	$V_{RMS}$	
at 0 °C		-	-	1250	$V_{RMS}$	
Operating Frequency	$f_{BL}$	40	60	70	kHz	5
Discharge Stabilization Time	$T_S$	-	-	3	Minutes	6
Power Consumption	$P_{BL}$	-	16.90	18.60	Watts	7
Life Time		50,000	-	-	Hrs	8

**Note.** The design of the inverter must have specifications for the lamp in LCD Assembly.

The performance of the Lamp in LCM, for example life time or brightness, is extremely influenced by the characteristics of the DC-AC Inverter. So all the parameters of an inverter should be carefully designed so as not to produce too much leakage current from high-voltage output of the inverter. When you design or order the inverter, please make sure unwanted lighting caused by the mismatch of the lamp and the inverter(no lighting, flicker, etc) never occurs. When you confirm it, the LCD Assembly should be operated in the same condition as installed in your instrument.

**Note.** Do not attach a conducting tape to lamp connecting wire. If the lamp wire attach to conducting tape, TFT-LCD Module have a low luminance and the inverter has abnormal action because leakage current occurs between lamp wire and conducting tape.

1. The specified current and power consumption are under the  $V_{CC}=5.0V$ ,  $25^{\circ}C$ ,  $f_v$ (frame frequency) =60Hz condition. Mosaic(black & white) pattern shown in the [ Figure 3 ] is displayed.
2. The duration of rush current is about 5ms. And  $V_{CC}$  rise time is  $500\mu s \pm 20\%$ .
3. Operating voltage is measured under  $25^{\circ}C$ . The variance of the voltage is  $\pm 10\%$ . (only min +20%)
4. The voltage above  $V_{BS}$  should be applied to the lamps for more than 1 second for start-up. Otherwise, the lamps may not be turned on.

**Product Specification**

5. The output of the inverter must have symmetrical(negative and positive) voltage waveform and symmetrical current waveform.(Unsymmetrical ratio is less than 10%) Please do not use the inverter which has unsymmetrical voltage and unsymmetrical current and spike wave.  
Lamp frequency may produce interference with horizontal synchronous frequency and as a result this may cause beat on the display.Therefore lamp frequency shall be as away as possible from the horizontal synchronous frequency and from its harmonics in order to prevent interference.
6. Let's define the brightness of the lamp after being lighted for 5 minutes as 100%.  
 $T_s$  is the time required for the brightness of the center of the lamp to be not less than 95%.  
The used lamp current is the lamp typical current.
7. The lamp power consumption shown above does not include loss of external inverter under 25°C.  
The used lamp current is the lamp typical current.
8. The life time is determined as the time at which brightness of lamp is 50% compared to that of initial value at the typical lamp current on condition of continuous operating at 25 ± 2°C.
9. Requirements for a system inverter design, which is intended to have a better display performance, a better power efficiency and a more reliable lamp.  
It shall help increase the lamp lifetime and reduce its leakage current.
  - a. The unbalance rate of the inverter waveform should be 10% below;
  - b. The distortion rate of the waveform should be within  $\sqrt{2} \pm 10\%$ ;
  - c. The ideal sine wave form shall be symmetric in positive and negative polarities.

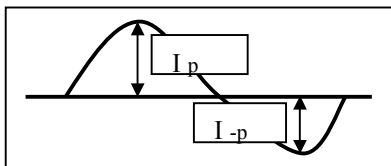

\* **Asymmetry rate** =  $| I_p - I_{-p} | / I_{rms} * 100\%$

\* **Distortion rate** =  $I_p$  (or  $I_{-p}$ ) /  $I_{rms}$

10. Inverter open voltage must be more than lamp starting voltage.
11. The inverter which is combined with this LCM, is highly recommended to connect coupling(ballast) condenser at the high voltage output side. When you use the inverter which has not coupling(ballast) condenser, it may cause abnormal lamp lighting because of biased mercury as time goes.

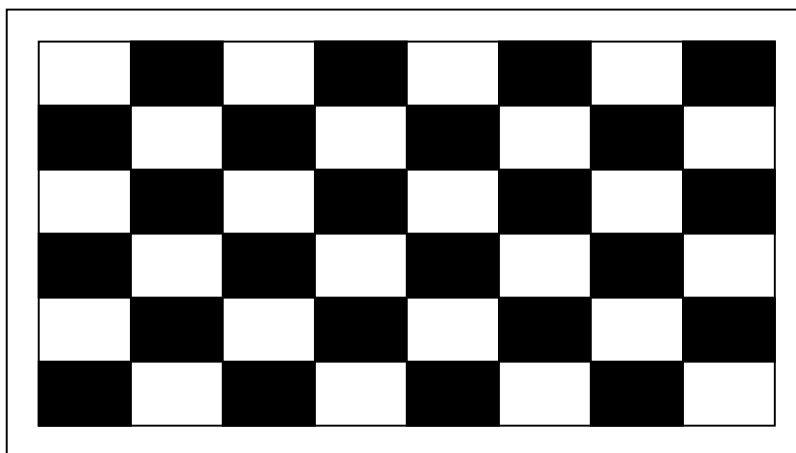

**[ Figure 3 ] Mosaic pattern for power consumption measurement**

**Product Specification**

**3-2. Interface Connections**

Interface chip must be used LVDS, part No. SN75LVDS83 (Tx, Texas Instrument) or compatible.  
 This LCD employs a interface connection, a 30 pin connector is used for the module electronics interface.  
 Four 2pin connectors are used for the integral backlight system. The electronics interface connector is a model IS100-L30B-C23 manufactured by UJU or KDF71G-30S-1H manufactured by Hirose or compatible connector. And mating connector is FI-X30H and FI-X30HL or it's compatible manufactured by JAE.  
 The pin configuration for the connector is shown in the table 3 and the signal mapping with LVDS transmitter is shown in the table 4.

**Table 3. Module connector pin configuration**

Pin No	Symbol	Description
1	RxO0-	LVDS Signal of Odd Channel 0(-)
2	RxO0+	LVDS Signal of Odd Channel 0(+)
3	RxO1-	LVDS Signal of Odd Channel 1(-)
4	RxO1+	LVDS Signal of Odd Channel 1(+)
5	RxO2-	LVDS Signal of Odd Channel 2(-)
6	RxO2+	LVDS Signal of Odd Channel 2(+)
7	GND	Ground
8	RxOC-	LVDS Signal of Odd Channel Clock(-)
9	RxOC+	LVDS Signal of Odd Channel Clock(+)
10	RxO3-	LVDS Signal of Odd Channel 3(-)
11	RxO3+	LVDS Signal of Odd Channel 3(+)
12	RxE0-	LVDS Signal of Even Channel 0(-)
13	RxE0+	LVDS Signal of Even Channel 0(+)
14	GND	Ground
15	RxE1-	LVDS Signal of Even Channel 1(-)
16	RxE1+	LVDS Signal of Even Channel 1(+)
17	GND	Ground
18	RxE2-	LVDS Signal of Even Channel 2(-)
19	RxE2+	LVDS Signal of Even Channel 2(+)
20	RxEC-	LVDS Signal of Even Channel Clock(-)
21	RxEC+	LVDS Signal of Even Channel Clock(+)
22	RxE3-	LVDS Signal of Even Channel 3(-)
23	RxE3+	LVDS Signal of Even Channel 3(+)
24	GND	Ground
25	NC	No connection
26	NC	No connection
27	NC	No connection
28	VCC	Power supply (5.0V Typ.)
29	VCC	Power supply (5.0V Typ.)
30	VCC	Power supply (5.0V Typ.)

First Pixel Data

Second Pixel Data



**Product Specification**

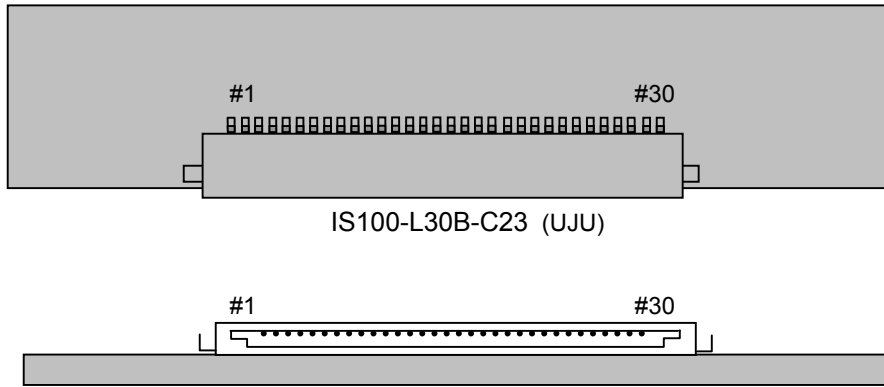

IS100-L30B-C23 (UJU)

Rear view of LCM

[ Figure 4 ] Connector diagram

- Notes:
1. All GND(ground) pins should be connected together and should also be connected to the LCD's metal frame.
  2. All  $V_{CC}$ (power input) pins should be connected together.
  3. All NC pins should be separated from other signal or power.

**Product Specification**

**Table 4. Required signal assignment for Flat Link (TI:SN75LVDS83) Transmitter**

Pin	Pin Name	Require Signal	Pin	Pin Name	Require Signal
1	VCC	Power Supply for TTL Input	29	GND	Ground pin for TTL
2	D5	TTL Input(R7)	30	D26	TTL Input(DE)
3	D6	TTL Input(R5)	31	TxCLKIN	TTL Level clock Input
4	D7	TTL Input(G0)	32	PWR DWN	Power Down Input
5	GND	Ground pin for TTL	33	PLL GND	Ground pin for PLL
6	D8	TTL Input(G1)	34	PLL VCC	Power Supply for PLL
7	D9	TTL Input(G2)	35	PLL GND	Ground pin for PLL
8	D10	TTL Input(G6)	36	LVDS GND	Ground pin for LVDS
9	VCC	Power Supply for TTL Input	37	TxOUT3+	Positive LVDS differential data output3
10	D11	TTL Input(G7)	38	TxOUT3-	Negative LVDS differential data output3
11	D12	TTL Input(G3)	39	TxCLKOUT+	Positive LVDS differential clock output
12	D13	TTL Input(G4)	40	TxCLKOUT-	Negative LVDS differential clock output
13	GND	Ground pin for TTL	41	TxOUT2+	Positive LVDS differential data output2
14	D14	TTL Input(G5)	42	TxOUT2-	Negative LVDS differential data output2
15	D15	TTL Input(B0)	43	LVDS GND	Ground pin for LVDS
16	D16	TTL Input(B6)	44	LVDS VCC	Power Supply for LVDS
17	VCC	Power Supply for TTL Input	45	TxOUT1+	Positive LVDS differential data output1
18	D17	TTL Input(B7)	46	TxOUT1-	Negative LVDS differential data output1
19	D18	TTL Input(B1)	47	TxOUT0+	Positive LVDS differential data output0
20	D19	TTL Input(B2)	48	TxOUT0-	Negative LVDS differential data output0
21	GND	Ground pin for TTL Input	49	LVDS GND	Ground pin for TTL
22	D20	TTL Input(B3)	50	D27	TTL Input(R6)
23	D21	TTL Input(B4)	51	D0	TTL Input(R0)
24	D22	TTL Input(B5)	52	D1	TTL Input(R1)
25	D23	TTL Input(RSVD)	53	GND	Ground pin for TTL
26	VCC	Power Supply for TTL Input	54	D2	TTL Input(R2)
27	D24	TTL Input(HSYNC)	55	D3	TTL Input(R3)
28	D25	TTL Input(VSYNC)	56	D4	TTL Input(R4)

Notes : 1. Refer to LVDS Transmitter Data Sheet for detail descriptions.  
2. 7 means MSB and 0 means LSB at R,G,B pixel data

**Product Specification**

The backlight interface connector is a model BHSR-02VS-1(JST).  
 The mating connector part number is SM02B-BHSS-1 or equivalent.  
 The pin configuration for the connector is shown in the table 5.

**Table 5. Backlight connector pin configuration**

Pin	Symbol	Description	Notes
1	HV	High Voltage for lamp	1
2	LV	Low Voltage for lamp	1,2

Notes : 1. The high voltage side terminal is colored white or pink. The low voltage side terminal is white or Blue.  
 2. The backlight ground should be common with LCD metal frame.

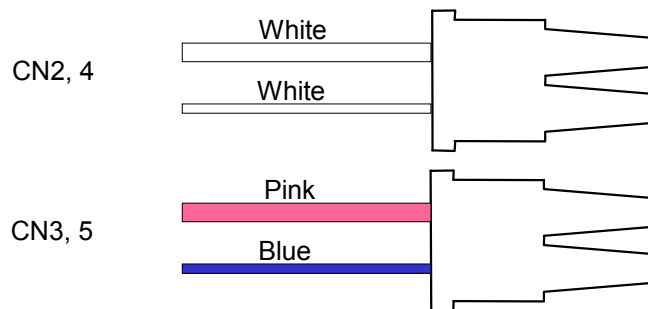

**[ Figure 5 ] Backlight connector view**

**Product Specification**

**3-3. Signal Timing Specifications**

This is the signal timing required at the input of the LVDS Transmitter. All of the interface signal timing should be satisfied with the following specifications for its proper operation.

**Table 6. Timing table**

	Parameter	Symbol	Min.	Typ.	Max.	Unit	Notes
Dclk	Period	$t_{CLK}$	14.71	18.52	22.22	ns	
	Frequency	$f_{CLK}$	45	54	68	MHz	
Hsync	Period	$t_{HP}$	672	844	1022	$t_{CLK}$	Horizontal period should be even
	Width	$t_{WH}$	8	56	-		
Vsync	Period	$t_{VP}$	1032	1066	1536	$t_{HP}$	
	Width	$t_{WV}$	2	3	24		
	Frequency	$f_V$	50	60	76	Hz	
DE (Data Enable)	Horizontal Valid	$t_{HV}$	640	640	640	$t_{CLK}$	
	Horizontal Back Porch	$t_{HBP}$	16	124	-		
	Horizontal Front Porch	$t_{HFP}$	8	24	-		
	-	-	-	-	-		
	Vertical Valid	$t_{VV}$	1024	1024	1024	$t_{HP}$	
	Vertical Back Porch	$t_{VBP}$	5	38	124		
	Vertical Front Porch	$t_{VFP}$	1	1	-		
	-	-	-	-	-		
	DE setup time	$t_{SI}$	4	-	-	ns	For Dclk
	DE hold time	$t_{HI}$	4	-	-		
Data	Data setup time	$t_{SD}$	4	-	-	ns	For Dclk
	Data hold time	$t_{HD}$	4	-	-		

Notes : 1. DE Only mode operation

2.  $t_{HFP} + t_{WH} + t_{HBP} < (1/2) t_{HV}$

3.  $t_{VFP} + t_{WV} + t_{VBP} < t_{H_{max}} / t_{V_{min}}$

4.  $t_{HFP}$ ,  $t_{WH}$  and  $t_{HBP}$  should be any times of a character number (8).

5. No variation of the total number of Hsync and DE in a frame is required for normal operation.

6. No variation of the total number of clock in a Hsync period for  $t_{VBP}$  is required for normal operation.

**Product Specification**

**3-4. Signal Timing Waveforms**

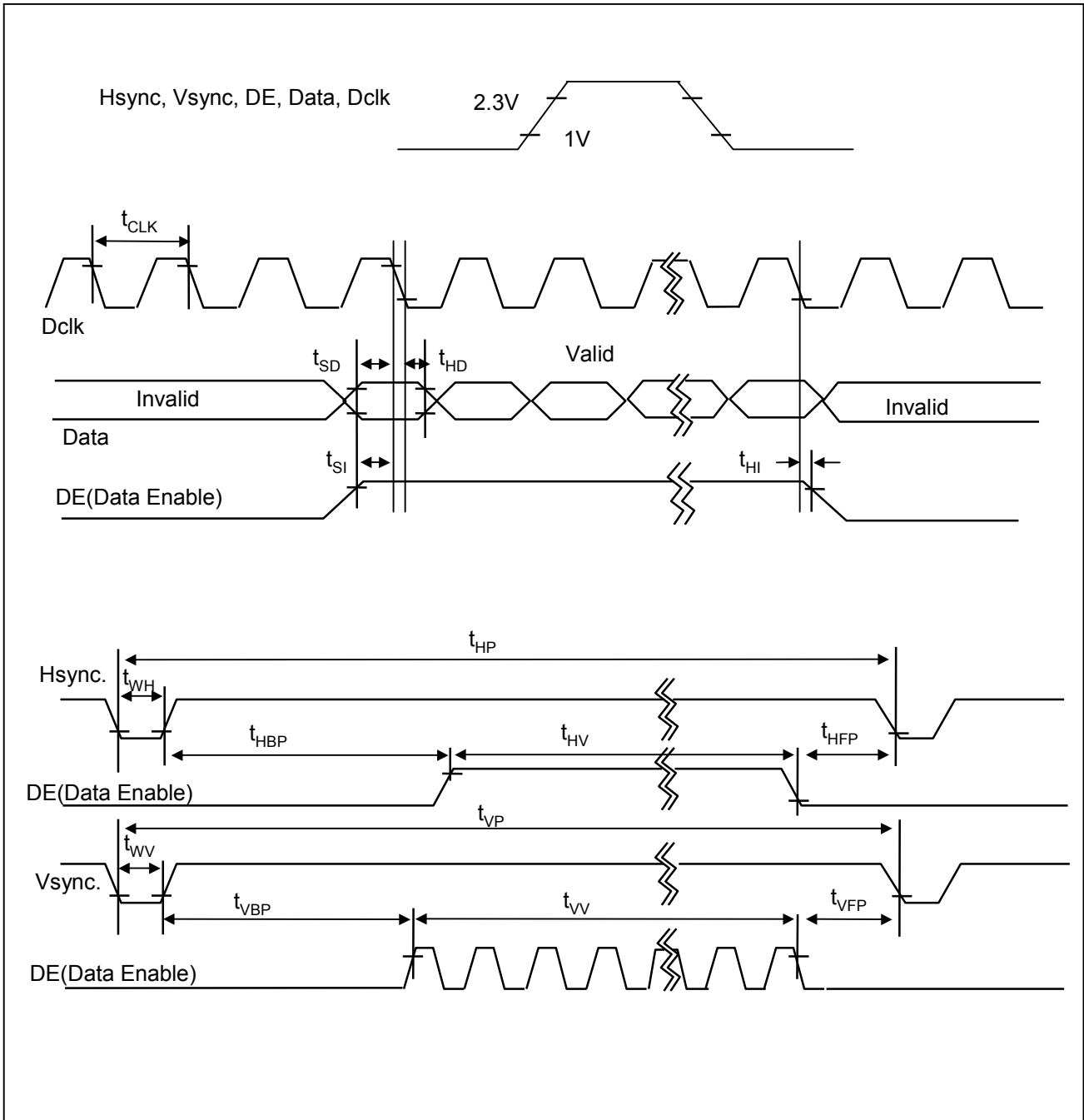

[ Figure 6 ] Signal timing waveforms

**Product Specification**

**3-5. Color Input Data Reference**

The brightness of each primary color(red,green and blue) is based on the 8-bit gray scale data input for the color ; the higher the binary input, the brighter the color. The table below provides a reference for color versus data input.

**Table 7. Color data reference**

Color	Input color data																							
	Red								Green								Blue							
	MSB				LSB				MSB				LSB				MSB				LSB			
	R7	R6	R5	R4	R3	R2	R1	R0	G7	G6	G5	G4	G3	G2	G1	G0	B7	B6	B5	B4	B3	B2	B1	B0
Basic colors	Black	0	0	0	0	0	0	0	0	0	0	0	0	0	0	0	0	0	0	0	0	0	0	0
	Red(255)	1	1	1	1	1	1	1	0	0	0	0	0	0	0	0	0	0	0	0	0	0	0	0
	Green(255)	0	0	0	0	0	0	0	1	1	1	1	1	1	1	1	0	0	0	0	0	0	0	0
	Blue(255)	0	0	0	0	0	0	0	0	0	0	0	0	0	0	0	1	1	1	1	1	1	1	1
	Cyan	0	0	0	0	0	0	0	1	1	1	1	1	1	1	1	1	1	1	1	1	1	1	1
	Magenta	1	1	1	1	1	1	1	0	0	0	0	0	0	0	0	1	1	1	1	1	1	1	1
	Yellow	1	1	1	1	1	1	1	1	1	1	1	1	1	1	1	0	0	0	0	0	0	0	0
	White	1	1	1	1	1	1	1	1	1	1	1	1	1	1	1	1	1	1	1	1	1	1	1
Red	Red(000) dark	0	0	0	0	0	0	0	0	0	0	0	0	0	0	0	0	0	0	0	0	0	0	
	Red(001)	0	0	0	0	0	0	1	0	0	0	0	0	0	0	0	0	0	0	0	0	0	0	
	Red(002)	0	0	0	0	0	0	1	0	0	0	0	0	0	0	0	0	0	0	0	0	0	0	
	:	:	:	:	:	:	:	:	:	:	:	:	:	:	:	:	:	:	:	:	:	:	:	
	Red(253)	1	1	1	1	1	1	0	1	0	0	0	0	0	0	0	0	0	0	0	0	0	0	
	Red(254)	1	1	1	1	1	1	1	0	0	0	0	0	0	0	0	0	0	0	0	0	0	0	
	Red(255) bright	1	1	1	1	1	1	1	1	0	0	0	0	0	0	0	0	0	0	0	0	0	0	
Green	Green(000)dark	0	0	0	0	0	0	0	0	0	0	0	0	0	0	0	0	0	0	0	0	0	0	
	Green(001)	0	0	0	0	0	0	0	0	0	0	0	0	0	0	1	0	0	0	0	0	0	0	
	Green(002)	0	0	0	0	0	0	0	0	0	0	0	0	0	1	0	0	0	0	0	0	0	0	
	:	:	:	:	:	:	:	:	:	:	:	:	:	:	:	:	:	:	:	:	:	:	:	
	Green(253)	0	0	0	0	0	0	0	1	1	1	1	1	1	0	1	0	0	0	0	0	0	0	
	Green(254)	0	0	0	0	0	0	0	1	1	1	1	1	1	1	0	0	0	0	0	0	0	0	
	Green(255)bright	0	0	0	0	0	0	0	1	1	1	1	1	1	1	1	0	0	0	0	0	0	0	
Blue	Blue(000) dark	0	0	0	0	0	0	0	0	0	0	0	0	0	0	0	0	0	0	0	0	0	0	
	Blue(001)	0	0	0	0	0	0	0	0	0	0	0	0	0	0	0	0	0	0	0	0	0	1	
	Blue(002)	0	0	0	0	0	0	0	0	0	0	0	0	0	0	0	0	0	0	0	0	0	1	
	:	:	:	:	:	:	:	:	:	:	:	:	:	:	:	:	:	:	:	:	:	:	:	
	Blue(253)	0	0	0	0	0	0	0	0	0	0	0	0	0	0	0	1	1	1	1	1	1	0	
	Blue(254)	0	0	0	0	0	0	0	0	0	0	0	0	0	0	0	1	1	1	1	1	1	0	
	Blue(255) bright	0	0	0	0	0	0	0	0	0	0	0	0	0	0	0	1	1	1	1	1	1	1	

**Product Specification**

**3-6. Power Sequence**

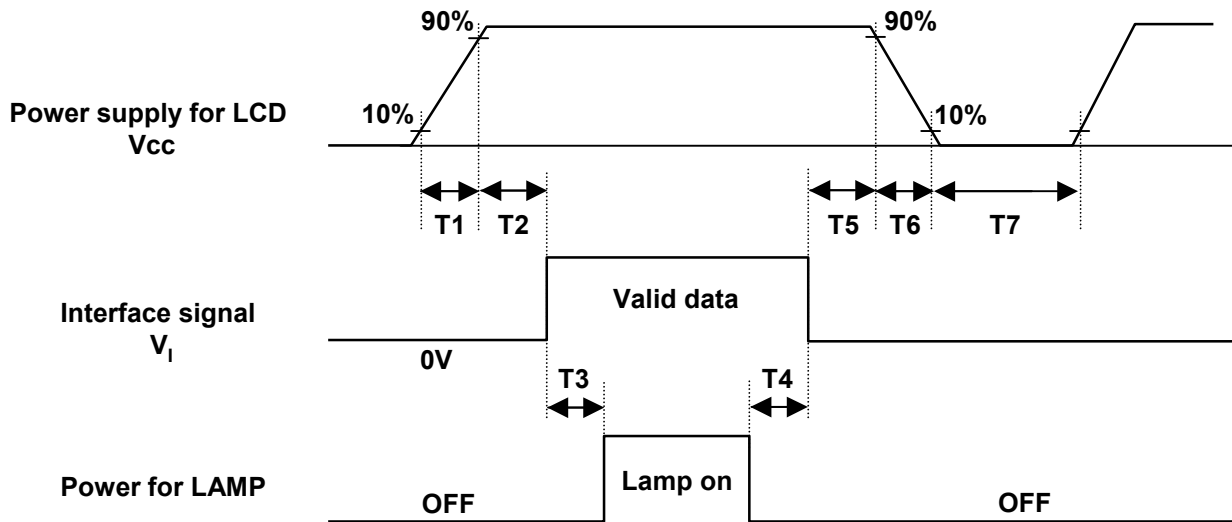

[ Figure 7 ] Power sequence

**Table 8. Power sequence time delay**

Parameter	Values			Units
	Min.	Typ.	Max.	
T <sub>1</sub>	-	-	10	ms
T <sub>2</sub>	0.01	-	50	ms
T <sub>3</sub>	200	-	-	ms
T <sub>4</sub>	200	-	-	ms
T <sub>5</sub>	0.01	-	50	ms
T <sub>6</sub>	0.01	-	10	ms
T <sub>7</sub>	1	-	-	s

- Notes :
1. Please avoid floating state of interface signal at invalid period.
  2. When the interface signal is invalid, be sure to pull down the power supply for LCD V<sub>CC</sub> to 0V.
  3. Lamp power must be turn on after power supply for LCD and interface signals are valid.

**Product Specification**

**3-7. V<sub>CC</sub> Power Dip Condition**

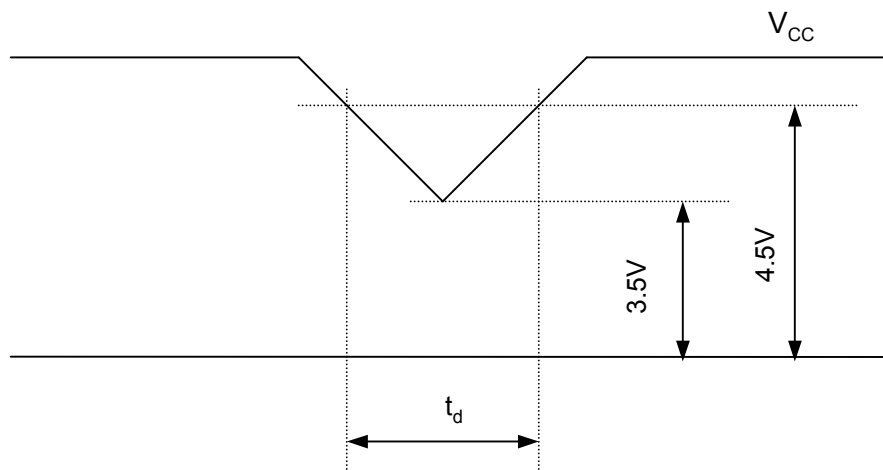

**[ Figure 8 ] Power dip condition**

1) Dip condition

$$3.5V \leq V_{CC} < 4.5V, t_d \leq 20ms$$

2)  $V_{CC} < 3.5V$

$V_{CC}$ -dip conditions should also follow the Power On/Off conditions for supply voltage.



**Product Specification**

**4. Optical Specifications**

Optical characteristics are determined after the unit has been 'ON' and stable for approximately 30 minutes in a dark environment at 25 °C. The values specified are measured at an approximate distance 50cm from the LCD surface at a viewing angle of  $\Phi$  and  $\theta$  equal to 0 °.

Figure. 9 presents additional information concerning the measurement equipment and method.

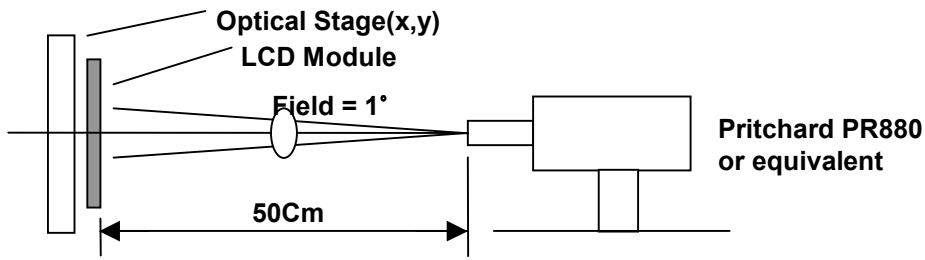

[Figure 9] Optical characteristic measurement equipment and method

**Table 9. Optical characteristics** (Ta=25 °C, V<sub>CC</sub>=5.0V, f<sub>V</sub>=60Hz Dclk=54MHz, I<sub>BL</sub>=6.5mA<sub>rms</sub>)

Parameter	Symbol	Values			Units	Notes
		Min.	Typ.	Max.		
Contrast ratio	CR	500	700	-		1
Surface luminance, white	L <sub>WH</sub>	250	300	-	cd/m <sup>2</sup>	2
Luminance uniformity	$\Delta L_g$	75	-	-	%	3
Response time	T <sub>r</sub>		8	18	ms	4
Rise time	T <sub>rR</sub>	-	2	6		
Decay time	T <sub>rD</sub>	-	6	12		
CIE color coordinates						
Red	XR	0.605	0.635	0.665		
	YR	0.312	0.342	0.372		
Green	XG	0.262	0.292	0.322		
	YG	0.581	0.611	0.641		
Blue	XB	0.117	0.147	0.177		
	YB	0.040	0.070	0.100		
White	XW	0.283	0.313	0.343		
	YW	0.299	0.329	0.359		
Viewing angle (by CR ≥ 10)						
X axis, right( $\phi=0^\circ$ )	$\theta_r$	60	70	-	degree	5
X axis, left ( $\phi=180^\circ$ )	$\theta_l$	60	70	-		
Y axis, up ( $\phi=90^\circ$ )	$\theta_u$	60	75	-		
Y axis, down ( $\phi=270^\circ$ )	$\theta_d$	50	65	-		
Viewing angle (by CR ≥ 5)						
X axis, right( $\phi=0^\circ$ )	$\theta_r$	70	80	-	degree	
X axis, left ( $\phi=180^\circ$ )	$\theta_l$	70	80	-		
Y axis, up ( $\phi=90^\circ$ )	$\theta_u$	70	85	-		
Y axis, down ( $\phi=270^\circ$ )	$\theta_d$	60	75	-		
Relative brightness						
Luminance uniformity (TCO99)		-	-	1.7		6 Figure 10

**Product Specification**

Notes : 1. Contrast ratio(CR) is defined mathematically as :

$$\text{Contrast ratio} = \frac{\text{Surface luminance with all white pixels}}{\text{Surface luminance with all black pixels}}$$

2. Surface luminance is the center point across the LCD surface 50cm from the surface with all pixels displaying white. For more information see [ Figure 10 ].  
When  $I_{BL}=6.5\text{mA}$ ,  $L_{WH}=250\text{cd/m}^2(\text{Min.})$   $300\text{cd/m}^2(\text{Typ.})$

3. The uniformity in surface luminance ,  $\Delta L_g$  is determined by measuring  $L_{ON}$  at any point in test area. But the management of  $\Delta L_g$  is determined by measuring  $L_{ON}$  at each test position 1 through 9, and then dividing the maximum  $L_{ON}$  of 9 points luminance by minimum  $L_{ON}$  of 9 points luminance. For more information see [ Figure 10 ].

$$\Delta L_g = \text{Minimum } (L_{ON1}, L_{ON2}, \dots, L_{ON9}) \div \text{Maximum } (L_{ON1}, L_{ON2}, \dots, L_{ON9}) \times 100 (\%)$$

4. Response time is the time required for the display to transition from white to black(Rise Time,  $Tr_R$ ) and from black to white(Decay Time,  $Tr_D$ ). For additional information see [ Figure 11 ].  
The sampling rate is 2,500 sample/sec.

5. Viewing angle is the angle at which the contrast ratio is greater than 10. The angles are determined for the horizontal or x axis and the vertical or y axis with respect to the z axis which is normal to the LCD surface. For more information see Figure 12 .

6. Gray scale specification

**Table 10. Gray scale**

Gray level	Luminance(%) (Typ.)
L0	0.16
L31	1.19
L63	5.04
L95	12.1
L127	22.5
L159	39.3
L191	62.1
L223	86.0
L255	100

**Product Specification**

**Figure 10. Luminance measuring point**

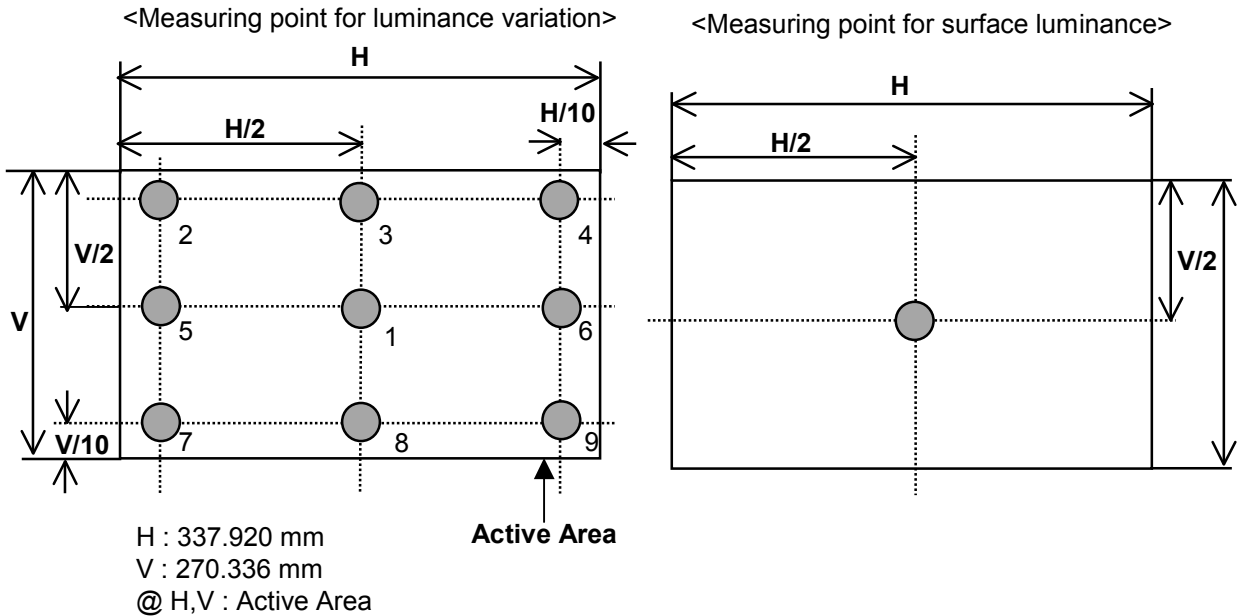

< Luminance Uniformity - angular – dependent ( $L_R$ ) >

TCO '99 Certification requirements and test methods for environmental labelling of Display [Flat] report No.2 (Luminance uniformity- angular – dependent)

Test pattern : 80% white pattern  
Test point : 2-point  
Test distance : 64.77cm  
Test method :  $L_R = ((L_{max.+30deg.} / L_{min. +30deg.}) + (L_{max. -30deg.} / L_{min. -30deg.})) / 2$

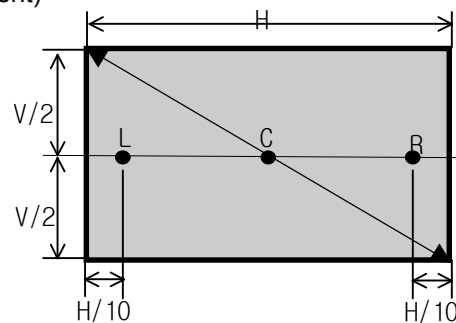

**Figure 11. Response time**

The response time is defined as the following Figure and shall be measured by switching the input signal for “black” and “white”.

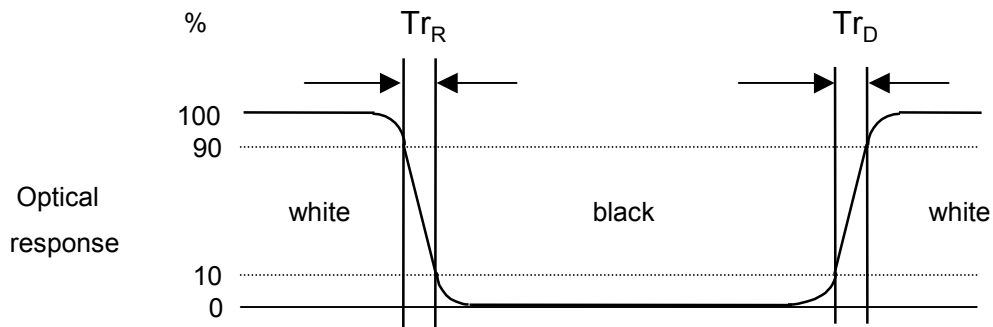

**Product Specification**

**Figure 12. Viewing angle**

<Dimension of viewing angle range>

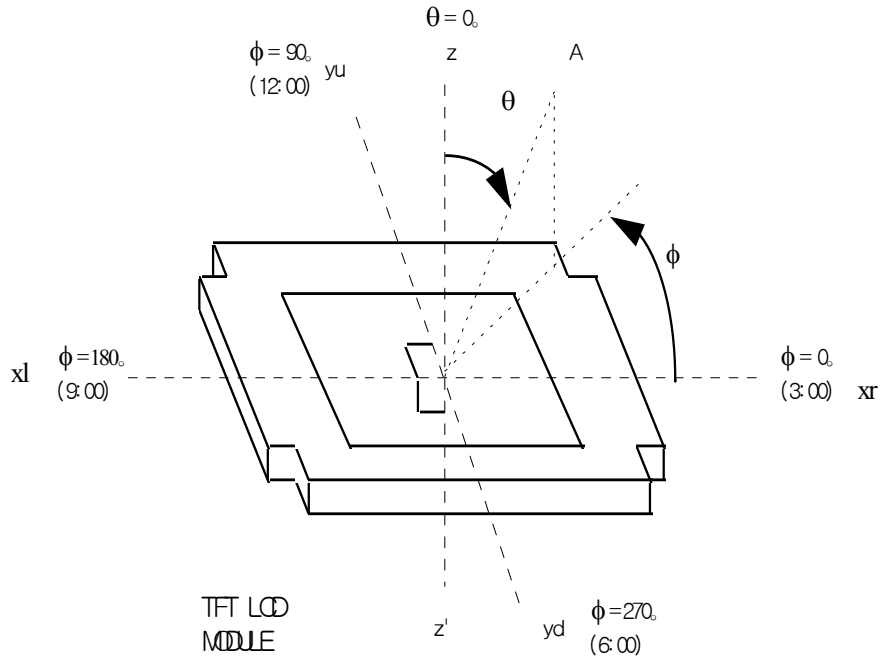

**Product Specification**

**5. Mechanical Characteristics**

Table 11. provides general mechanical characteristics for the model LM170E01-TLB3. Please refer to Figure 15,16 regarding the detailed mechanical drawing of the LCD.

**Table 11. Mechanical characteristics**

Outside dimensions	Horizontal	358.5 ± 0.5mm
	Vertical	296.5 ± 0.5mm
	Depth	17.0 ± 0.5mm
Bezel area	Horizontal	341.6 ± 0.5mm
	Vertical	274.0 ± 0.5mm
Active display area	Horizontal	337.920mm
	Vertical	270.336mm
Weight(approximate)	2150g(Typ.), 2300g(Max.)	
Surface Treatment	Hard coating(3H) Anti-glare treatment of the front polarizer	

**Product Specification**

**Figure 15. Front view**

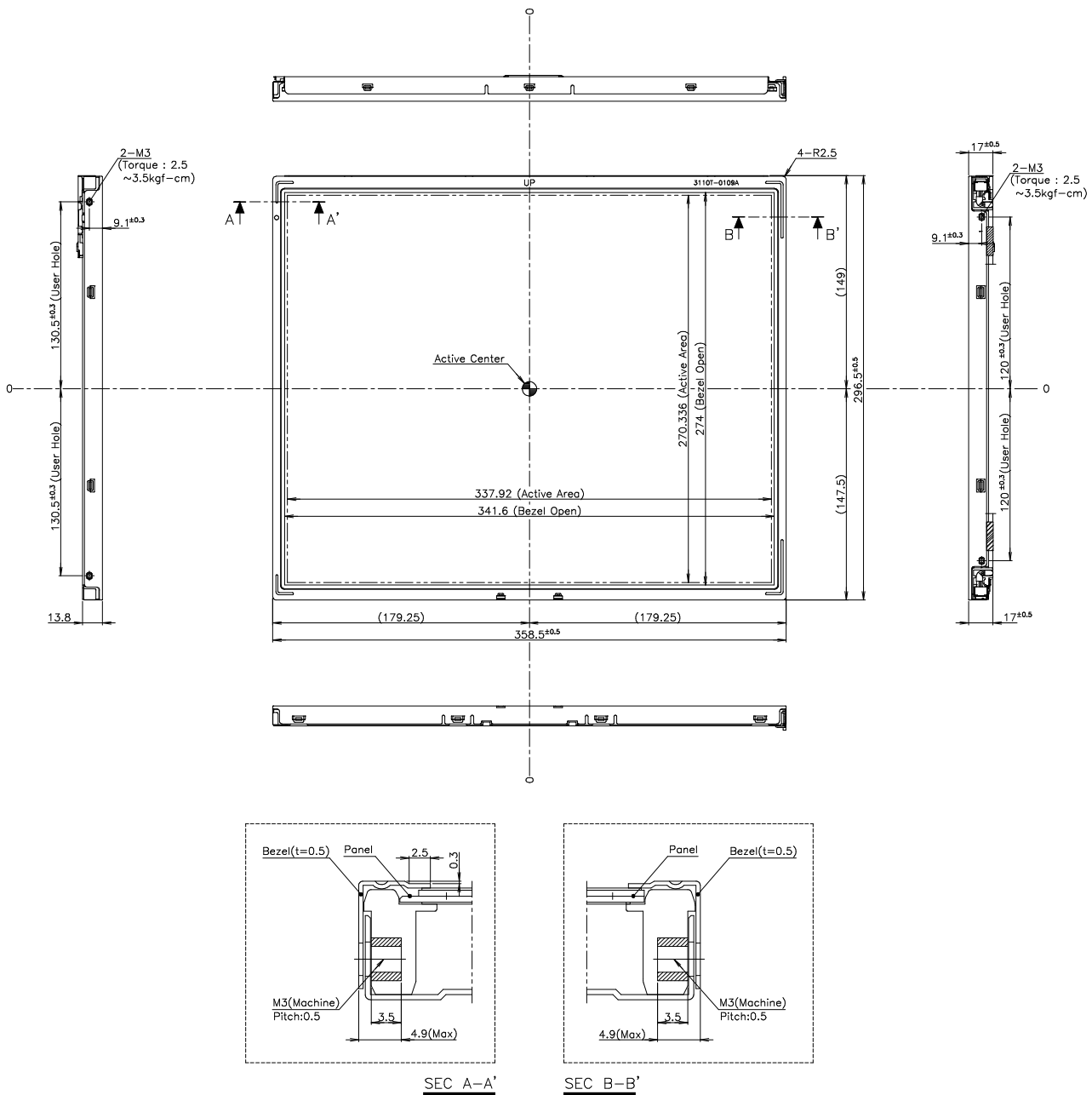

**Product Specification**

**Figure 15. Rear view**

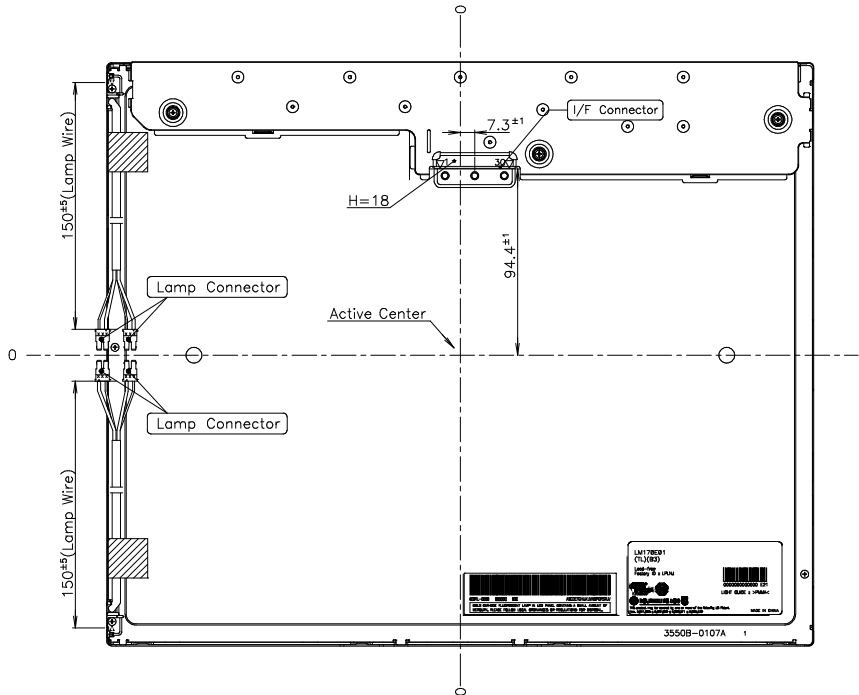

**NOTES**

1. Backlight : 4 Cold Cathode Fluorescent Lamps.
2. I/F Connector Specification.  
 - UJU IS100-L30B-C23 or Equivalent.
3. Lamp Connector Specification.  
 - JST BHSR-02VS-1 Only.
4. Depth of user hole screw insertion : Max 4.9mm.
5. Torque of user hole : 2.5~3.5kgf-cm.
6. Gap between Bezel and Panel : Max 0.6mm.
7. Tilt and partial disposition tolerance of display area as following.  
 (1) Y-Direction :  $|A-B| \leq 1.0$   
 (2) X-Direction :  $|C-D| \leq 1.0$

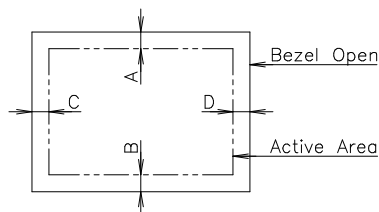

8. Lamp(CCFL) lot No. is marked at backlight connector.

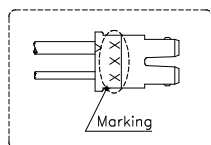

9. Do not wind conductive tape around the backlight wires.
10. Unspecified tolerances to be  $\pm 0.5\text{mm}$ .

**Product Specification**

**6. Reliability**

**Table 12. Environment test condition**

No.	Test item	Conditions
1	High temperature storage test	Ta= 60°C 240h
2	Low temperature storage test	Ta= -20°C 240h
3	High temperature operation test	Ta= 50°C 50%RH 240h
4	Low temperature operation test	Ta= 0°C 240h
5	Vibration test (non-operating)	Wave form : random Vibration level : 1.0G RMS Bandwidth : 10-500Hz Duration : X,Y,Z, 20 min. One time each direction
6	Shock test (non-operating)	Shock level : 120G Waveform : half sine wave, 2ms Direction : ±X, ±Y, ±Z One time each direction
7	Altitude storage / shipment	0 - 40,000 feet(12,192m)

{ Result evaluation criteria }

There should be no change which might affect the practical display function when the display quality test is conducted under normal operating condition.



## Product Specification

### 7. International Standards

#### 7-1. Safety

- a) UL 60950-1:2003, First Edition, Underwriters Laboratories, Inc., Standard for Safety of Information Technology Equipment.
- b) CAN/CSA C22.2, No. 60950-1-03 1<sup>st</sup> Ed. April 1, 2003, Canadian Standards Association, Standard for Safety of Information Technology Equipment.
- c) EN 60950-1:2001, First Edition, European Committee for Electrotechnical Standardization(CENELEC) European Standard for Safety of Information Technology Equipment.
- d) RoHS, Directive 2002/95/EC of the European Parliament and of the council of 27 January 2003

#### 7-2. EMC

- a) ANSI C63.4 "Methods of Measurement of Radio-Noise Emissions from Low-Voltage Electrical and Electrical Equipment in the Range of 9kHz to 40GHz. "American National Standards Institute(ANSI), 1992
- b) C.I.S.P.R. "Limits and Methods of Measurement of Radio Interface Characteristics of Information Technology Equipment." International Special Committee on Radio Interference.
- c) EN 55022 "Limits and Methods of Measurement of Radio Interface Characteristics of Information Technology Equipment." European Committee for Electrotechnical Standardization.(CENELEC), 1998 ( Including A1: 2000 )

**Product Specification**

**8. Packing**

**8-1. Designation of Lot Mark**

a) Lot Mark

A	B	C	D	E	F	G	H	I	J	K	L	M
---	---	---	---	---	---	---	---	---	---	---	---	---

A,B,C : SIZE(INCH)  
E : MONTH

D : YEAR  
F ~ M : SERIAL NO.

Note

1. YEAR

Year	2001	2002	2003	2004	2005	2006	2007	2008	2009	2010
Mark	1	2	3	4	5	6	7	8	9	0

2. MONTH

Month	Jan	Feb	Mar	Apr	May	Jun	Jul	Aug	Sep	Oct	Nov	Dec
Mark	1	2	3	4	5	6	7	8	9	A	B	C

b) Location of Lot Mark

Serial No. is printed on the label. The label is attached to the backside of the LCD module.  
This is subject to change without prior notice.

**8-2. Packing Form**

a) Package quantity in one box : 9 pcs

b) Box size : 492mm X 434mm X 380mm

## Product Specification

### 9. Precautions

Please pay attention to the following when you use this TFT LCD module.

#### 9-1. Mounting Precautions

- (1) You must mount a module using holes arranged in four corners or four sides.
- (2) You should consider the mounting structure so that uneven force(ex. twisted stress) is not applied to the module.  
And the case on which a module is mounted should have sufficient strength so that external force is not transmitted directly to the module.
- (3) Please attach a transparent protective plate to the surface in order to protect the polarizer.  
Transparent protective plate should have sufficient strength in order to resist external force.
- (4) You should adopt radiation structure to satisfy the temperature specification.
- (5) Acetic acid type and chlorine type materials for the cover case are not describe because the former generates corrosive gas of attacking the polarizer at high temperature and the latter causes circuit break by electro-chemical reaction.
- (6) Do not touch, push or rub the exposed polarizers with glass, tweezers or anything harder than HB pencil lead. And please do not rub with dust clothes with chemical treatment.  
Do not touch the surface of polarizer for bare hand or greasy cloth.(Some cosmetics are determined to the polarizer.)
- (7) When the surface becomes dusty, please wipe gently with absorbent cotton or other soft materials like chamois soaks with petroleum benzene. Normal-hexane is recommended for cleaning the adhesives used to attach front / rear polarizers. Do not use acetone, toluene and alcohol because they cause chemical damage to the polarizer.
- (8) Wipe off saliva or water drops as soon as possible. Their long time contact with polarizer causes deformations and color fading.
- (9) Do not open the case because inside circuits do not have sufficient strength.

#### 9-2. Operating Precautions

- (1) The spike noise causes the mis-operation of circuits. It should be lower than following voltage :  
 $V = \pm 200\text{mV}$ (Over and under shoot voltage)
- (2) Response time depends on the temperature.(In lower temperature, it becomes longer.)
- (3) Brightness depends on the temperature. (In lower temperature, it becomes lower.)  
And in lower temperature, response time(required time that brightness is stable after turned on) becomes longer.
- (4) Be careful for condensation at sudden temperature change. Condensation makes damage to polarizer or electrical contacted parts. And after fading condensation, smear or spot will occur.
- (5) When fixed patterns are displayed for a long time, remnant image is likely to occur.
- (6) Module has high frequency circuits. Sufficient suppression to the electromagnetic interference shall be done by system manufacturers. Grounding and shielding methods may be important to minimized the interference.
- (7) Please do not give any mechanical and/or acoustical impact to LCM. Otherwise, LCM can not be operated its full characteristics perfectly.
- (8) A screw which is fastened up the steels should be a machine screw (if not, it causes metal foreign material and deal LCM a fatal blow)

## Product Specification

### 9-3. Electrostatic Discharge Control

Since a module is composed of electronic circuits, it is not strong to electrostatic discharge. Make certain that treatment persons are connected to ground through wrist band etc. And don't touch interface pin directly.

### 9-4. Precautions for Strong Light Exposure

Strong light exposure causes degradation of polarizer and color filter.

### 9-5. Storage

When storing modules as spares for a long time, the following precautions are necessary.

- (1) Store them in a dark place. Do not expose the module to sunlight or fluorescent light. Keep the temperature between 5°C and 35°C at normal humidity.
- (2) The polarizer surface should not come in contact with any other object.  
It is recommended that they be stored in the container in which they were shipped.

### 9-6. Handling Precautions for Protection Film

- (1) The protection film is attached to the bezel with a small masking tape.  
When the protection film is peeled off, static electricity is generated between the film and polarizer. This should be peeled off slowly and carefully by people who are electrically grounded and with well ion-blown equipment or in such a condition, etc.
- (2) When the module with protection film attached is stored for a long time, sometimes there remains a very small amount of glue still on the bezel after the protection film is peeled off.
- (3) You can remove the glue easily. When the glue remains on the bezel or its vestige is recognized, please wipe them off with absorbent cotton waste or other soft material like chamois soaked with normal-hexane.