

**Product Specification**

## SPECIFICATION FOR APPROVAL

- (◆) Preliminary Specification  
( ) Final Specification

<b>Title</b>	<b>13.3" XGA TFT LCD</b>
--------------	--------------------------

<b>BUYER</b>	
<b>MODEL</b>	

<b>SUPPLIER</b>	<b>LG.PHILIPS LCD Co.,Ltd</b>
<b>MODEL</b>	<b>LP133X7-F2IB</b>
<b>Safety Application Model</b>	<b>LP133X7</b>

<b>SIGNATURE</b>	<b>DATE</b>
/	_____
/	_____
/	_____

<b>APPROVED BY</b>	<b>DATE</b>
<b>S. H. Kang / G. Manager</b>	_____
<b>REVIEWED BY</b>	
<b>S. C. Yoon / Manager</b>	_____
<b>B. H. Koo / Manager</b>	_____
<b>PREPARED BY</b>	
<b>J. C. Hong / Engineer</b>	_____
<b>W. J. Lee / Engineer</b>	_____

Please return 1 copy for your confirmation with your signature and comments.

Product Engineering Dept.  
LG.PHILIPS LCD Co.,Ltd

**Product Specification****CONTENTS**

<b>NO.</b>	<b>ITEM</b>	<b>Page</b>
-	<b>COVER</b>	<b>1</b>
-	<b>CONTENTS</b>	<b>2</b>
-	<b>RECORD OF REVISIONS</b>	<b>3</b>
<b>1</b>	<b>GENERAL DESCRIPTION</b>	<b>4</b>
<b>2</b>	<b>ABSOLUTE MAXIMUM RATINGS</b>	<b>5</b>
<b>3</b>	<b>ELECTRICAL SPECIFICATIONS</b>	<b>6</b>
3-1	<b>ELECTRICAL CHARACTERISTICS</b>	<b>6</b>
3-2	<b>INTERFACE CONNECTIONS</b>	<b>7</b>
3-3	<b>SIGNAL TIMING SPECIFICATIONS</b>	<b>9</b>
3-4	<b>SIGNAL TIMING WAVEFORMS</b>	<b>10</b>
3-5	<b>COLOR INPUT DATA REFERENCE</b>	<b>11</b>
3-6	<b>POWER SEQUENCE</b>	<b>12</b>
3-7	<b>Vcc DIP CONDITION</b>	<b>13</b>
<b>4</b>	<b>OPTICAL SPECIFICATIONS</b>	<b>14</b>
<b>5</b>	<b>MECHANICAL CHARACTERISTICS</b>	<b>15</b>
<b>6</b>	<b>RELIABILITY</b>	<b>19</b>
<b>7</b>	<b>INTERNATIONAL STANDARDS</b>	<b>20</b>
7-1	<b>SAFETY</b>	<b>20</b>
7-2	<b>EMC</b>	<b>20</b>
<b>8</b>	<b>PACKING</b>	<b>21</b>
8-1	<b>DESIGNATION OF LOT MARK</b>	<b>21</b>
8-2	<b>PACKING FORM</b>	<b>21</b>
<b>9</b>	<b>PRECAUTIONS</b>	<b>22</b>
	<b>APPENDIX</b>	
A-1	<b>OPTICAL CHARACTERISTIC MEASUREMENT EQUIPMENT AND METHOD</b>	<b>24</b>
A-2	<b>LUMINANCE</b>	<b>24</b>
A-3	<b>RESPONSE TIME</b>	<b>24</b>
A-4	<b>VIEWING ANGLE</b>	<b>25</b>

Product Specification

**RECORDS OF REVISIONS**

Version No	Date	Page	DESCRIPTION
0.0	DEC. 20, 1999	-	First Draft
0.1	Mar. 6, 2000	p6	Inverter design and lamp description added.
		p7	Connector change(DF19KR-20P-1H → DF19L-20P-1H)
		p14	CIE Color Coordinates (Red, Green, Blue) value change by the standard of IBM spec.
		p17	Rear View : B/L Label added.
		p18	Description of side mounting screw: Unify the expression of screw length with LP141X6-A1IB Change Drawings(B/L Wire)
0.2	April.17,2000	p1	Add "Safety Application Model" Box
		p12	Change Power Sequence Spec(T2, T5); 20ms→50ms(max)
		p16-17	Change Drawings(Concerning B/L Wire, Label)
		p18	Change Screw Torque; 1.3-1.5kgf.cm →Max 2kgf.cm

**Product Specification**

**1. General Description**

The LP133X7-F2IB is a Color Active Matrix Liquid Crystal Display with an integral Cold Cathode Fluorescent Lamp(CCFL) backlight system. The matrix employs a-Si Thin Film Transistor as the active element. It is a transmissive type display operating in the normally white mode. This TFT-LCD has a 13.3 inch diagonally measured active display area with XGA resolution(768 vertical by 1024 horizontal pixel array). Each pixel is divided into Red, Green and Blue sub-pixels or dots which are arranged in vertical stripes. Gray scale or the brightness of the sub-pixel color is determined with a 6-bit gray scale signal for each dot, thus, presenting a palette of more than 262,144 colors.

The LP133X7-F2IB has been designed to apply the interface method that enables low power, high speed low EMI. Flat Link must be used as a LVDS(Low Voltage Differential Signaling) chip.

The LP133X7-F2IB is intended to support applications where thin thickness, low power are critical factors and graphic displays are important. In combination with the vertical arrangement of the sub-pixels, the LP133X7-F2IB characteristics provide an excellent flat panel display for office automation products such as Notebook PC.

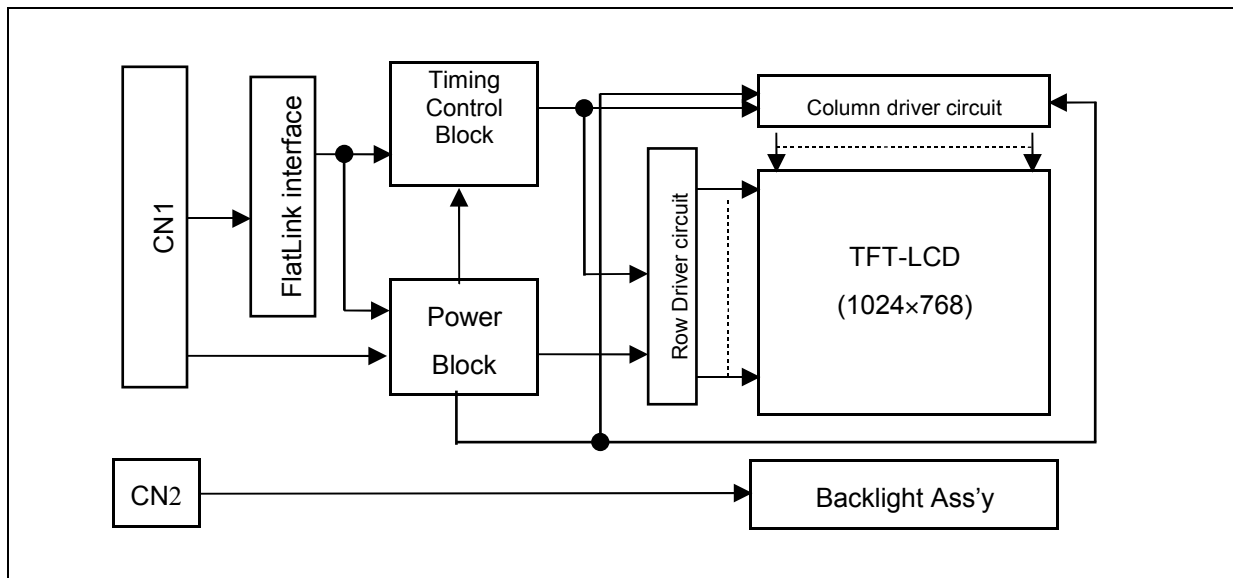

**General Features**

- Active screen size            13.3 inches(33.78cm) diagonal
- Outline dimensions           284(H) × 214.5(V) × 5.8(D) mm (typ)
- Pixel pitch                    0.264 mm × 0.264 mm
- Pixel format                  1024 horiz. by 768 vert. pixels
- RGB stripe arrangement
- Color depth                    6-bit, 262,144 colors
- Luminance, White            150 cd/m<sup>2</sup> (typ)
- Power Consumption          Total 4.6Watt(typ)
- Weight                         485g (typ)
- Display operating mode      Transmissive mode, normally white
- Surface treatments          Hard Coating(3H)
- Anti-glare treatment of the front polarizer

Product Specification

## 2. Absolute Maximum Ratings

The following are maximum values which, if exceeded, may cause faulty operation or damage to the unit.

**Table 1 ABSOLUTE MAXIMUM RATINGS**

Parameter	symbol	Values		Units	Notes
		Min.	Max.		
Power Input Voltage	$V_{CC}$	-0.3	+3.6	Vdc	at 25□
Operating Temperature	$T_{OP}$	0	+50	□	1,2
Storage Temperature	$T_{ST}$	-20	+60	□	1,2

Note: 1. Temperature at 5mm above display center of LCD Module.

$T_a \leq 40^\circ\text{C}$  : 90%RH Max.

$T_a \neq 40^\circ\text{C}$  : Absolute Humidity shall be less than  $T_a = 40^\circ\text{C}$  90%RH.

These shall be no dew condensation.

2. Humidity Min. 5%RH, Max. 90%RH.

**Product Specification**

**3. Electrical Specifications**

**3-1. Electrical Characteristics**

The LP133X7-F2IB requires two power inputs. One is employed to power the LCD electronics and to drive the TFT array and liquid crystal. The second input which powers the CCFL, is typically generated by an inverter. The inverter is an external unit to the LCD.

**Table 2 ELECTRICAL CHARACTERISTICS:**

Parameter	Symbol	Values			Units	Notes
		Min.	Typ.	Max.		
<b>MODULE:</b>						
Power Supply Input Voltage	V <sub>CC</sub>	3.0	3.3	3.6	Vdc	
Power Supply Input Current	I <sub>CC</sub>	0.185	0.215	0.245	A	1
Differential Impedance	Z <sub>m</sub>	90	100	110	ohm	2
Power Consumption	P <sub>c</sub>	0.61	0.71	0.81	Watts	1
Rush current	I <sub>RUSH</sub>	-	1.5	1.8	A	3
<b>LAMP</b>						
Operating Voltage	V <sub>BL</sub>	635	650	810	V <sub>RMS</sub>	4
Operating Current	I <sub>BL</sub>	3.0	6.0	6.5	mA	
Established Starting Voltage	V <sub>s</sub>					5
at 25□		-	-	1100	V <sub>RMS</sub>	
at 0□		-	-	1450	V <sub>RMS</sub>	
<b>Discharge Stabilization Time</b>	<b>T<sub>s</sub></b>			<b>3</b>	<b>min</b>	7
Operating Frequency	f <sub>BL</sub>	40	55	70	kHz	6
Power Consumption	P <sub>BL</sub>	2.43	3.9	4.13	Watts	8
Life Time		10,000	(15,000)	-	Hrs	9

Notes: **The design of the inverter must have specifications for the lamp in LCD Assembly.**

The performance of the Lamp in LCM, for example life time or brightness, is extremely influenced by the characteristics of the DC-AC Inverter. So all the parameters of an inverter should be carefully designed so as not to produce too much leakage current from high-voltage output of the inverter.

When you design or order the inverter, please make sure unwanted lighting caused by the mismatch of the lamp and the inverter (no lighting, flicker, etc) never occurs. When you confirm it, the LCD Assembly should be operated in the same condition as installed in your instrument.

- The specified current and power consumption are under the V<sub>cc</sub> = 3.3V, 25□, f<sub>v</sub> = 60Hz condition whereas 64 gray pattern is displayed.
- This impedance value is needed to proper display and measured from LVDS Tx to the mating connector.
- The duration of rush current is about 20ms.
- The variance of the voltage is ±10%.
- The voltage above V<sub>s</sub> should be applied to the lamps for more than 1 second for start-up. Otherwise, the lamps may not be turned on.
- The output of the inverter must have symmetrical (negative and positive) voltage waveform and symmetrical current waveform. (Unsymmetrical ratio is less than 10%) Please do not use the inverter which has unsymmetrical voltage and unsymmetrical current and spike wave.  
Lamp frequency may produce interference with horizontal synchronous frequency and as a result this may cause beat on the display. Therefore lamp frequency shall be as away as possible from the horizontal synchronous frequency and from its harmonics in order to prevent interference.
- Let's define the brightness of the lamp after being lighted for 5 minutes as 100%.  
T<sub>s</sub> is the time required for the brightness of the center of the lamp to be not less than 95%.
- The lamp power consumption shown above does not include loss of external inverter.
- The life time is determined as the time at which brightness of lamp is 50% compared to that of initial value at the typical lamp current on condition of continuous operating at 25 ±2□.



**Product Specification**

- Notes: 1. The high voltage input terminal is colored white.  
2. The low voltage input terminal is colored black.



**Product Specification**

**Table 5 REQUIRED SIGNAL ASSIGNMENT FOR FlatLink Transmitter**

Pin #	Pin Name	Require Signals	Pin #	Pin Name	Require Signals
1	D4	R4	48	D3	R3
2	Vcc	Vcc	47	D2	R2
3	D5	R5	46	GND	GND
4	D6	G0	45	D1	R1
5	GND	GND	44	D0	R0
6	D7	G1	43	NC	NC
7	D8	G2	42	LVDS GND	LVDS GND
8	Vcc	Vcc	41	Y0M	A0M
9	D9	G3	40	Y0P	A0P
10	D10	G4	39	Y1M	A1M
11	GND	GND	38	Y1P	A1P
12	D11	G5	37	LVDS Vcc	LVDS Vcc
13	D12	B0	36	LVDS GND	LVDS GND
14	NC	NC	35	Y2M	A2M
15	D13	B1	34	Y2P	A2P
16	D14	B2	33	CLKOUTM	CLKM
17	GND	GND	32	CLKOUTP	CLKP
18	D15	B3	31	LVDS GND	LVDS GND
19	D16	B4	30	PLL GND	PLL GND
20	D17	B5	29	PLL Vcc	PLL Vcc
21	Vcc	Vcc	28	PLL GND	PLL GND
22	D18	HSYNC	27	SHDN	SHDN
23	D19	VSYNC	26	CLKIN	Dclk
24	GND	GND	25	D20	DE(Data Enable)

Notes : Refer to LVDS Transmitter Data Sheet for detail descriptions.

**Product Specification**

**3-3. Signal Timing Specifications**

This is the signal timing required at the input of the LVDS Transmitter. All of the interface signal timing should be satisfied with the following specifications for its proper operation.

**Table 6 Timing Table**

	ITEM	SYMBOL	MIN.	TYP.	MAX.	UNIT	NOTE
Dclk	Period	$t_{CLK}$	14.7	15.4	16.7	ns	65MHz(Typ)
Hsync	Period	$t_{HP}$	1206	1344	1364	$t_{CLK}$	
	Width-Active	$t_{WH}$	16	136	240		
Vsync	Period	$t_{VP}$	780	806	830	$t_{HP}$	
	Frequency	$f_V$	-	60	-	Hz	
	Width-Active	$t_{WV}$	1	6	24	$t_{HP}$	
DE ( Data Enable )	Horizontal Back Porch	$t_{HBP}$	32	160	-	$t_{CLK}$	
	Horizontal Front Porch	$t_{HFP}$	10	24	-		
	Vertical Back Porch	$t_{VBP}$	2	29	-	$t_{HP}$	
	Vertical Front Porch	$t_{VFP}$	1	3	-		

**Product Specification**

**3-4. Signal Timing Wave forms**

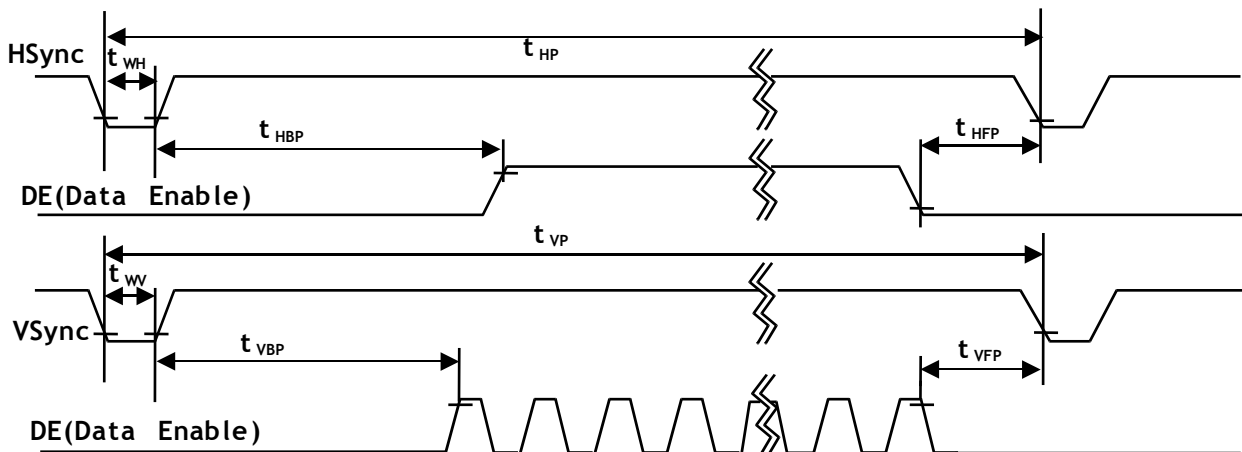
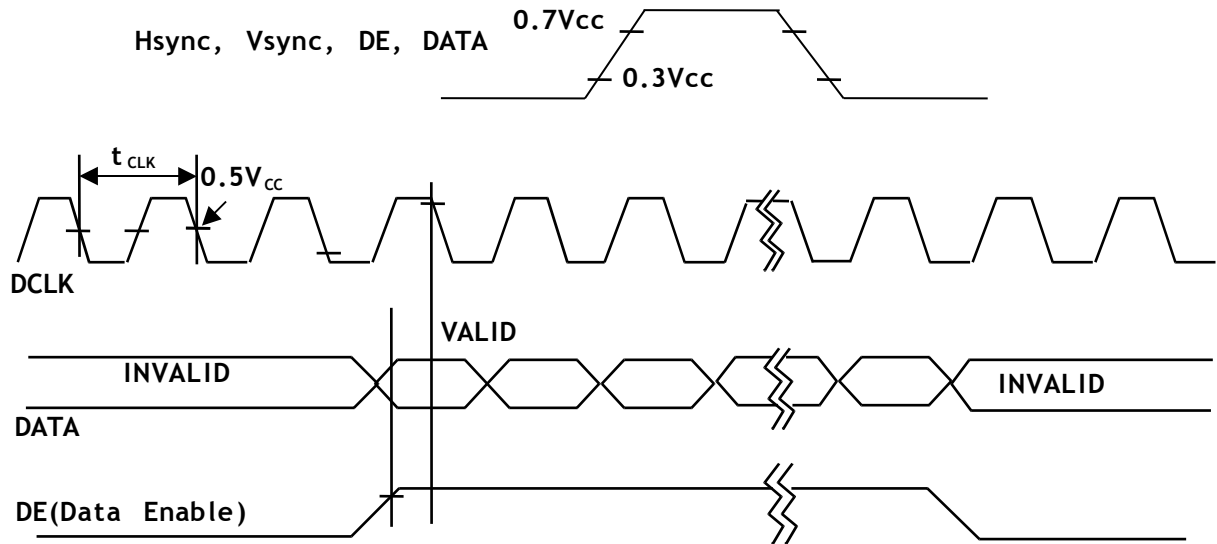

**Product Specification**

### 3-5. Color Input Data Reference

The brightness of each primary color(red, green and blue) is based on the 6-bit gray scale data input for the color; the higher the binary input, the brighter the color. The table below provides a reference for color versus data input.

**Table 7 COLOR DATA REFERENCE**

Color		Input Color Data																
		Red						Green						Blue				
		MSB			LSB			MSB			LSB			MSB		LSB		
		R5	R4	R3	R2	R1	R0	G5	G4	G3	G2	G1	G0	B5	B4	B3	B2	B1
Basic Colors	Black	0	0	0	0	0	0	0	0	0	0	0	0	0	0	0	0	0
	Red(63)	1	1	1	1	1	1	0	0	0	0	0	0	0	0	0	0	0
	Green(63)	0	0	0	0	0	0	1	1	1	1	1	1	0	0	0	0	0
	Blue(63)	0	0	0	0	0	0	0	0	0	0	0	1	1	1	1	1	1
	Cyan	0	0	0	0	0	0	1	1	1	1	1	1	1	1	1	1	1
	Magenta	1	1	1	1	1	1	0	0	0	0	0	0	1	1	1	1	1
	Yellow	1	1	1	1	1	1	1	1	1	1	1	1	0	0	0	0	0
	White	1	1	1	1	1	1	1	1	1	1	1	1	1	1	1	1	1
Red	Red(00) Dark	0	0	0	0	0	0	0	0	0	0	0	0	0	0	0	0	0
	Red(01)	0	0	0	0	0	1	0	0	0	0	0	0	0	0	0	0	0
	Red(02)	0	0	0	0	1	0	0	0	0	0	0	0	0	0	0	0	0
	⋮	⋮	⋮	⋮	⋮	⋮	⋮	⋮	⋮	⋮	⋮	⋮	⋮	⋮	⋮	⋮	⋮	⋮
	Red(61)	1	1	1	1	0	1	0	0	0	0	0	0	0	0	0	0	0
	Red(62)	1	1	1	1	1	0	0	0	0	0	0	0	0	0	0	0	0
	Red(63) Bright	1	1	1	1	1	1	0	0	0	0	0	0	0	0	0	0	0
Green	Green(00)Dark	0	0	0	0	0	0	0	0	0	0	0	0	0	0	0	0	0
	Green(01)	0	0	0	0	0	0	0	0	0	0	1	0	0	0	0	0	0
	Green(02)	0	0	0	0	0	0	0	0	0	1	0	0	0	0	0	0	0
	⋮	⋮	⋮	⋮	⋮	⋮	⋮	⋮	⋮	⋮	⋮	⋮	⋮	⋮	⋮	⋮	⋮	⋮
	Green(61)	0	0	0	0	0	0	1	1	1	1	0	1	0	0	0	0	0
	Green(62)	0	0	0	0	0	0	1	1	1	1	1	0	0	0	0	0	0
	Green(63)Bright	0	0	0	0	0	0	1	1	1	1	1	1	0	0	0	0	0
Blue	Blue(00) Dark	0	0	0	0	0	0	0	0	0	0	0	0	0	0	0	0	0
	Blue(01)	0	0	0	0	0	0	0	0	0	0	0	0	0	0	0	0	1
	Blue(02)	0	0	0	0	0	0	0	0	0	0	0	0	0	0	0	1	0
	⋮	⋮	⋮	⋮	⋮	⋮	⋮	⋮	⋮	⋮	⋮	⋮	⋮	⋮	⋮	⋮	⋮	⋮
	Blue(61)	0	0	0	0	0	0	0	0	0	0	0	1	1	1	1	0	1
	Blue(62)	0	0	0	0	0	0	0	0	0	0	0	1	1	1	1	1	0
	Blue(63) Bright	0	0	0	0	0	0	0	0	0	0	0	1	1	1	1	1	1

### 3-6. Power Sequence

**Product Specification**

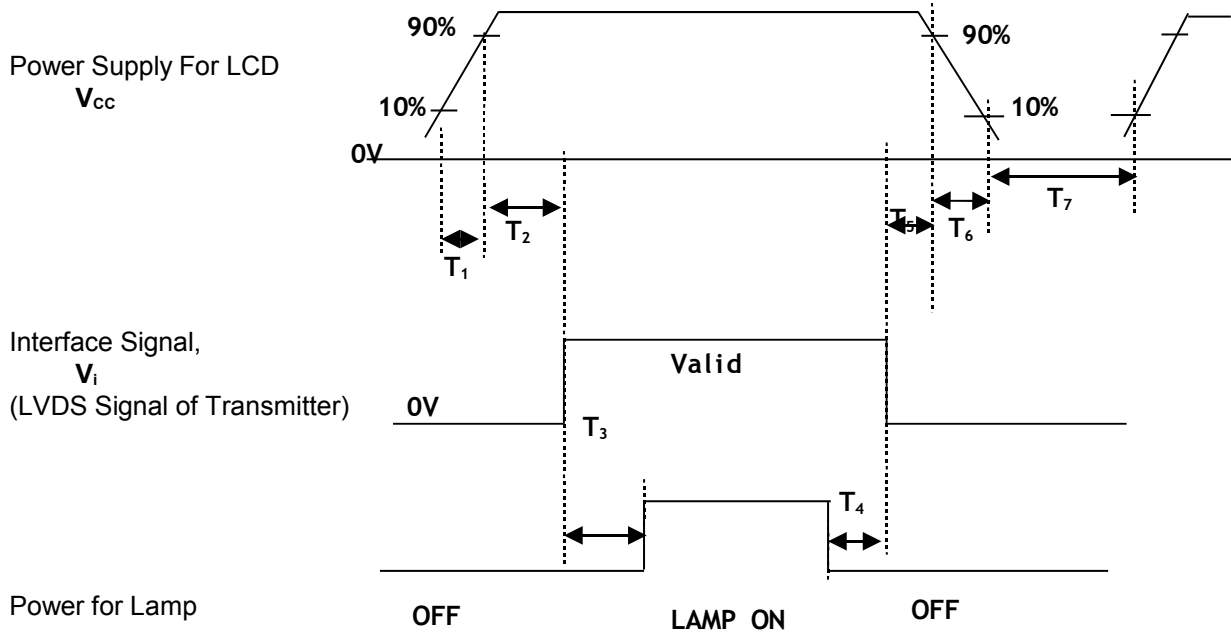

Parameter	Values			Units
	Min.	Typ.	Max.	
T <sub>1</sub>	0.01	-	10	ms
T <sub>2</sub>	0.01	-	50	ms
T <sub>3</sub>	50	-	-	ms
T <sub>4</sub>	50	-	-	ms
T <sub>5</sub>	0.01	-	50	ms
T <sub>6</sub>	0.01	-	20	ms
T <sub>7</sub>	1	-	-	s

- Notes:
1. Please avoid floating state of interface signal at invalid period.
  2. When the interface signal is invalid, be sure to pull down the power supply for LCD  $V_{cc}$  to 0V.
  3. Lamp power must be turn on after power supply for LCD and interface signal are valid.

**Product Specification**

**3-7. Vcc Dip Condition**

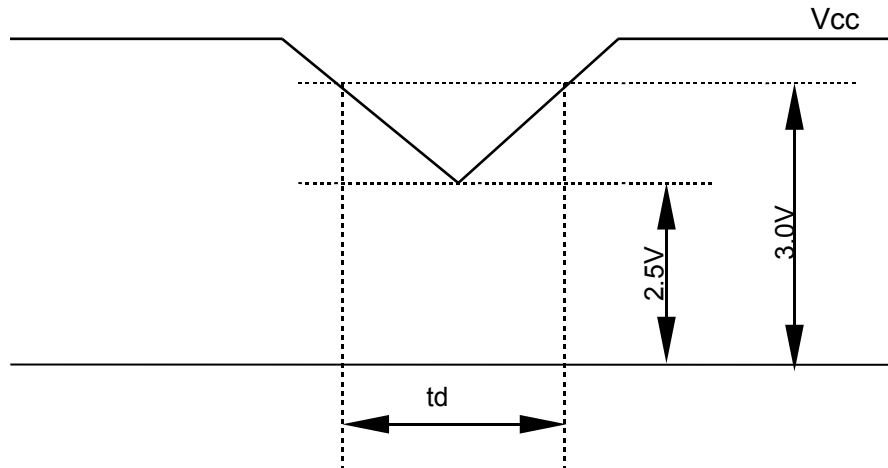

1)  $2.5V \leq V_{cc} \leq 3.0V$

$t_d \leq 20ms$

2)  $V_{cc} \geq 2.5V$

Vcc-dip conditions should also follow the Power Up/Down conditions for supply voltage.

Notes : This phenomenon is caused by row driver IC initialization after power on (1 vertical period) .

**Product Specification**

**4. Optical Specifications**

Optical characteristics are determined after the unit has been 'ON' and stable for approximately 30 minutes in a dark environment at 25°C. The values specified are at an approximate distance 50cm from the LCD surface at a viewing angle of Φ and θ equal to 0°.

Appendix A -1 presents additional information concerning the measurement equipment and method.

**Table 8 OPTICAL CHARACTERISTICS** ( Ta=25°C, Vcc=3.3V, f<sub>v</sub> =60Hz, Dclk=65MHz, I<sub>BL</sub>=6.0mA)

Parameter	Symbol	Values			Units	Notes
		Min.	Typ.	Max.		
Contrast Ratio	CR	150	200	-		1
Surface Luminance, white	L <sub>WH</sub>	130	150	-	cd/m <sup>2</sup>	2
Luminance Variation	δ <sub>WHITE</sub>	-	1.25	1.45	msec	3
Response Time	T <sub>r</sub>					4
Rise Time	T <sub>rR</sub>	-	30	50		
Decay Time	T <sub>rD</sub>	-	30	50		
CIE Color Coordinates	X <sub>R</sub>					
Red	y <sub>R</sub>					
Green	X <sub>G</sub>	0.547	0.577	0.607		
Blue	y <sub>G</sub>	0.308	0.338	0.368		
White	X <sub>B</sub>	0.280	0.310	0.340		
	y <sub>B</sub>	0.533	0.563	0.593		
	X <sub>w</sub>	0.128	0.158	0.188		
	y <sub>w</sub>	0.127	0.157	0.187		
		0.285	0.313	0.341		
		0.309	0.329	0.349		
Viewing Angle	θ <sub>x</sub>				degree	
x axis, right (Φ=0°)	θ <sub>xl</sub>					
x axis, left(Φ=180°)	θ <sub>yl</sub>	40	-	-		5
y axis, up(Φ=90°)	θ <sub>yd</sub>	40	-	-		
y axis, down (Φ=270°)		10	-	-		
		30	-	-		
Gray Scale		-	-	-		6

- Notes
1. Contrast Ratio (CR) is defined mathematically as :  

$$\text{Contrast Ratio} = \frac{\text{Surface Luminance with all white pixels}}{\text{Surface Luminance with all black pixels}}$$
  2. Surface luminance is the center points across the LCD surface 50cm from the surface with all pixels displaying white. For more information see Appendix A - 2.
  3. The variation in surface luminance, δ<sub>WHITE</sub> is determined by measuring L<sub>ON</sub> at each test position 1 through 5, and then dividing the maximum L<sub>ON</sub> of 5 points luminance by minimum L<sub>ON</sub> of 5 points luminance. For more information see Appendix A - 2.  

$$\delta_{\text{WHITE}} = \text{Maximum} (L_{\text{ON}1}, L_{\text{ON}2}, \dots, L_{\text{ON}5}) \div \text{Minimum} (L_{\text{ON}1}, L_{\text{ON}2}, \dots, L_{\text{ON}5})$$
  4. Response time is the time required for the display to transition from white to black (Rise Time,

**Product Specification**

Tr<sub>R</sub>) and from black to white (Decay Time, Tr<sub>D</sub>). For additional information see Appendix A - 3.

5. Viewing angle is the angle at which the contrast ratio is greater than 10. The angles are determined for the horizontal or x axis and the vertical or y axis with respect to the z axis which is normal to the LCD surface. For more information see Appendix A - 4

6. Gray scale specification.

Gray Level	Luminance (%) (typ)
L0	0.4
L7	1.6
L15	4.1
L23	9.0
L31	19.5
L39	36.0
L47	58.0
L55	82.0
L63	100

**5. Mechanical Characteristics**

The contents provide general mechanical characteristics for the model LP133X7-F2IB LCD. In addition, the figures in the next page are detailed mechanical drawings of the LCD.

Outside dimensions :

Horizontal	284 ±0.5 mm
Vertical	214.5 ±0.5 mm
Depth	5.8 ±0.3 mm

Bezel area :

Horizontal	273.4 ±0.5 mm
Vertical	205.8 ±0.5 mm

Active Display area :

Horizontal	270.34 mm
Vertical	202.75 mm

Weight (approximate) : 485g (typ), 500g(max)

Surface Treatment : Hard coating (3H)

Anti-glare treatment of the front polarizer



**Product Specification**

< FRONT VIEW >

Notes 1. Unspecified dimensional tolerances are  $\pm 0.5\text{mm}$

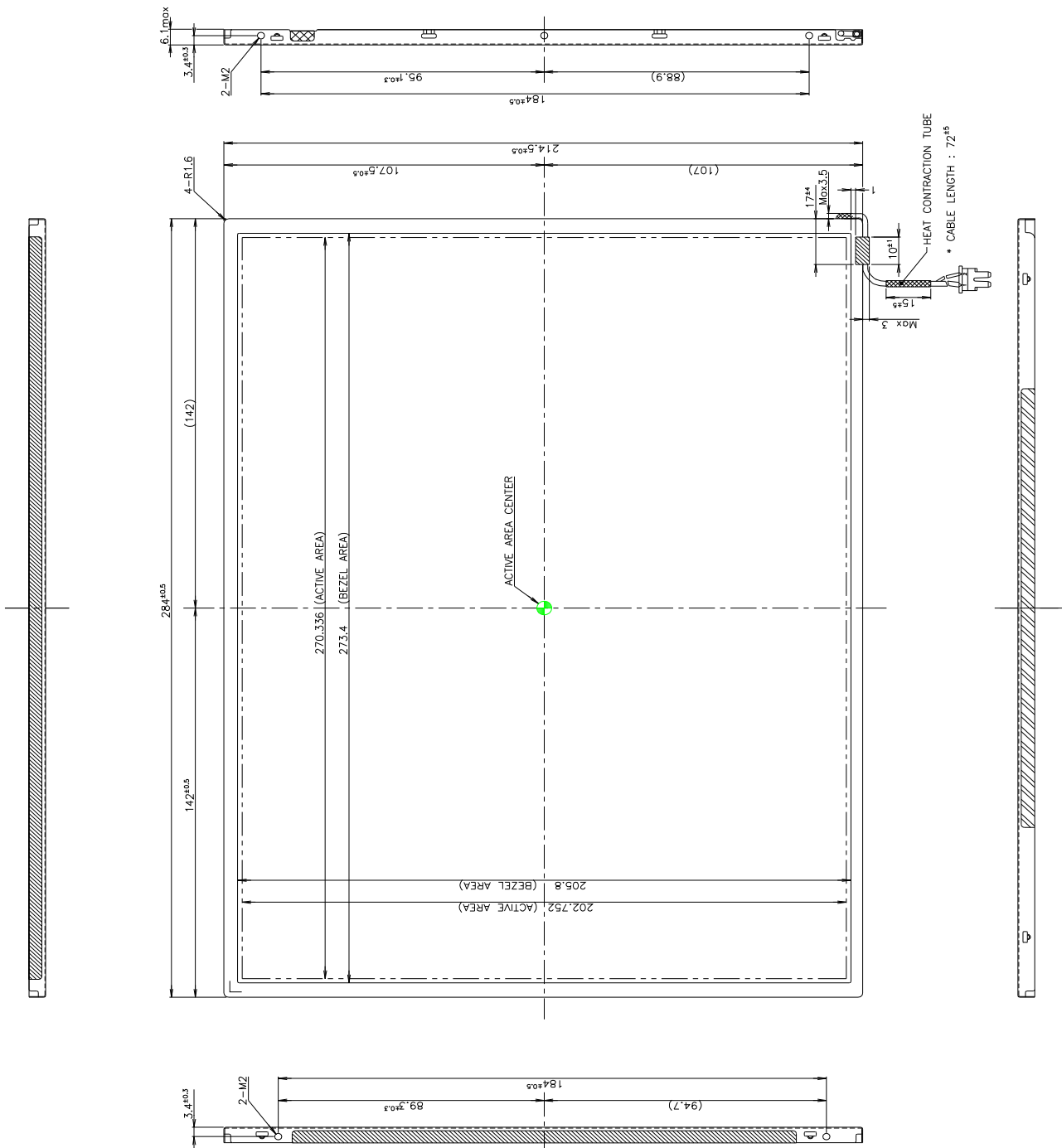

**Product Specification**

< REAR VIEW >

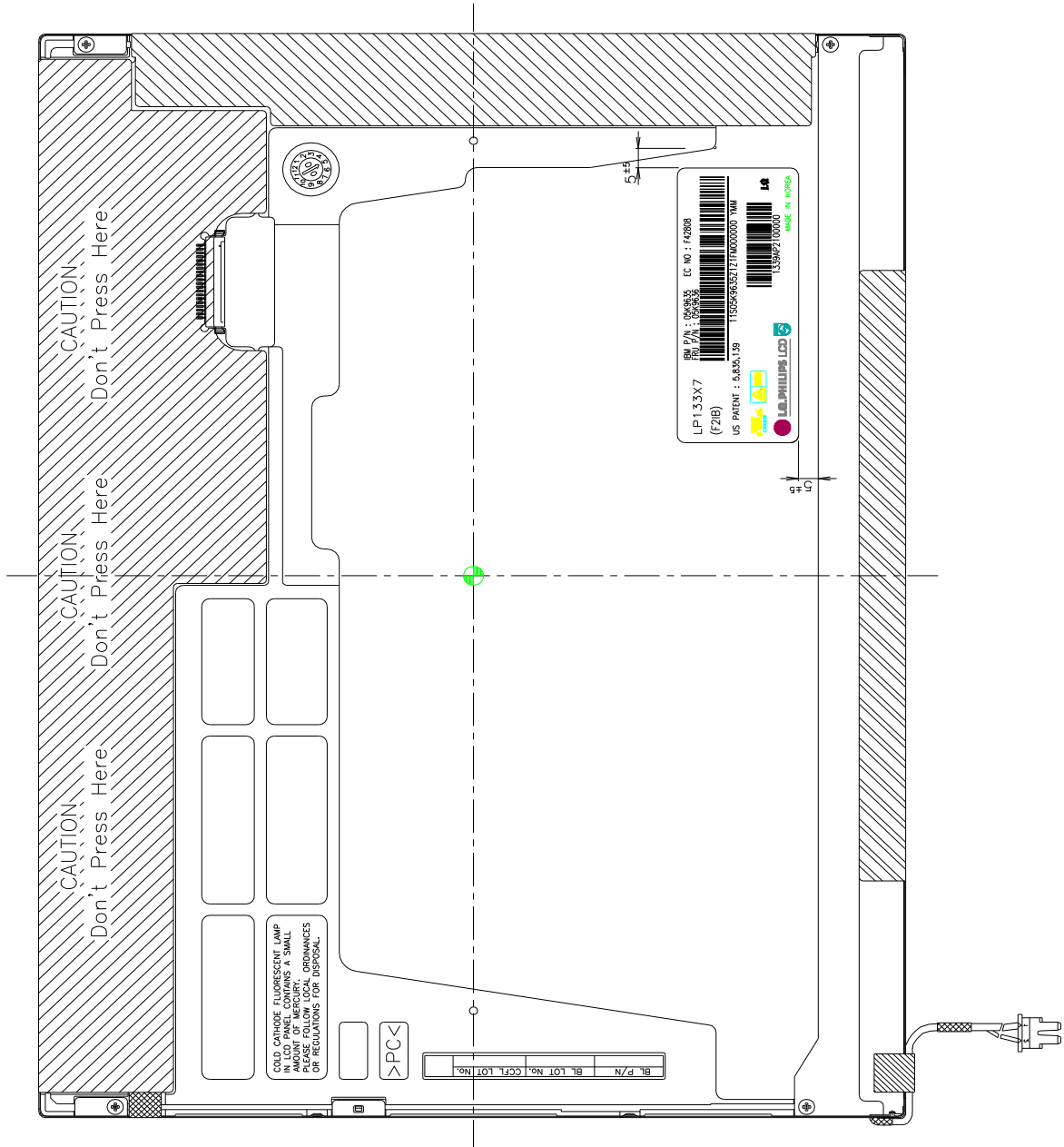

**Product Specification**

<Detail description of side mounting screw>

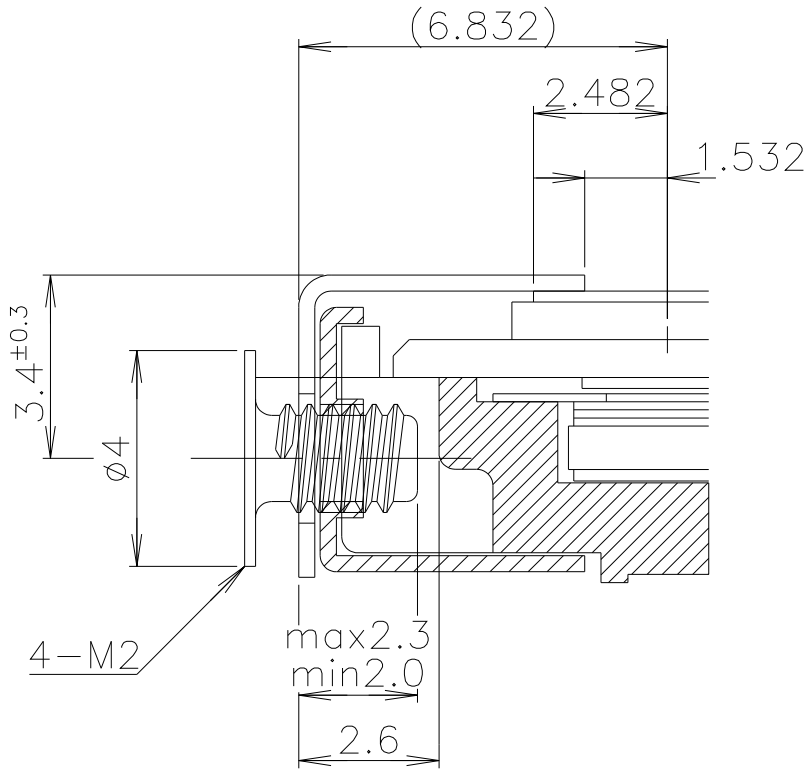

**Notes**

1. Screw Torque : Max 2.0 kgf.cm

**Product Specification**

**6. Reliability**

- Environment test condition

No.	Test Item	Conditions
1	High temperature storage test	Ta = 60□ 240h
2	Low temperature storage test	Ta = -20□ 240h
3	High temperature operation test	Ta = 50□ 80%RH 240h
4	Low temperature operation test	Ta = 0□ 240h
5	Vibration test (non-operating)	Sine wave, 10~500~10Hz, 1.5G, 0.37oct/min, 3 axis, 1 hour/axis
6	Shock test (non-operating)	Half sine wave, 100G, 6ms, one shock of each six faces.
7	Altitude operating storage/shipment	0 - 10,000 feet (3048m) 0 - 40,000 feet (12192m)

{Result Evaluation Criteria}

There should be no change which might affect the practical display function when the display quality test is conducted under normal operating condition.

- ON/OFF Cycle

: The display module will be capable of being operated over 24,000 ON/OFF cycles (Lamp power & Vcc ON/OFF)

- Mean Time Between Failure

: The LCD Panel and interface board assembly (excluding the CCFL) have a mean time between failures of 30,000 hours with a confidence level 90%.

**Product Specification****7. International Standards****7-1. Safety**

- a) UL 1950 Third Edition, Underwriters Laboratories, Inc. Jan. 28, 1995.  
Standard for Safety of Information Technology Equipment Including Electrical Business Equipment.
- b) CAN/CSA C22.2 No. 950-95 Third Edition, Canadian Standards Association, Jan. 28, 1995.  
Standard for Safety of Information Technology Equipment Including Electrical Business Equipment.
- c) EN 60950 : 1992 + A1 : 1993 + A2 : 1993 + A3 : 1995 + A4 : 1997 + A11 : 1997  
IEC 950 : 1991 + A1 : 1992 + A2 : 1993 + A3 : 1995 + A4 : 1996  
European Committee for Electrotechnical Standardization (CENELEC)  
EUROPEAN STANDARD for Safety of Information Technology Equipment Including Electrical Business Equipment.

**7-2. EMC**

- a) ANSI C63.4 "Methods of Measurement of Radio-Noise Emissions from Low-Voltage Electrical and Electronic Equipment in the Range of 9kHz to 40GHz." American National Standards Institute(ANSI),1992.
- b) C.I.S.P.R "Limits and Methods of Measurement of Radio Interference Characteristics of Information Technology Equipment." International Special Committee on Radio Interference
- c) EN 55022 "Limits and Methods of Measurement of Radio Interference Characteristics of Information Technology Equipment." European Committee for Electrotechnical Standardization (CENELEC),1988

**Product Specification**

## 8. Packing

### 8-1. Designation of Lot Mark

a) Lot Mark

A	B	C	D	E	F	G	H	I	J	K	L	M
---	---	---	---	---	---	---	---	---	---	---	---	---

A, B, C : INCH CODE  
 D : YEAR  
 E : MONTH  
 F, G : PANEL FACTORY  
 H : MODULE LINE  
 I, J, K, L, M : SERIAL NO

Note 1. YEAR(D)

YEAR	95	96	97	98	99	00	01	02	03	04	05
Mark	5	6	7	8	9	0	1	2	3	4	5

2. MONTH(E)

MONTH	Jan.	Feb.	Mar.	Apr.	May	Jun.	Jul.	Aug.	Sep.	Oct.	Nov.	Dec.
Mark	1	2	3	4	5	6	7	8	9	A	B	C

3. MODULE LINE(H)

LINE	1	2	3	4	5	6	7	8	9	10	11	12	13
Mark	1	2	3	4	5	6	7	8	9	A	B	C	D

b) Location of Lot Mark

Serial NO. Is printed on the label. The label is attached to the backside of the LCD module.  
 This is subject to change without prior notice.

### 8-2. Packing Form

a) Package quantity in one box : 10 PCS

b) Box Size : 374mm X 329mm X 311mm

## 9. PRECAUTIONS

Please pay attention to the followings when you use this TFT LCD module.

### 9.1 MOUNTING PRECAUTIONS

- (1) You must mount a module using holes arranged in four corners or four sides.
- (2) You should consider the mounting structure so that uneven force (ex. twisted stress) is not applied to the module.  
And the case on which a module is mounted should have sufficient strength so that external force is not transmitted directly to the module.
- (3) Please attach a transparent protective plate to the surface in order to protect the polarizer.  
Transparent protective plate should have sufficient strength in order to resist external force.
- (4) You should adopt radiation structure to satisfy the temperature specification.
- (5) Acetic acid type and chlorine type materials for the cover case are not desirable because the former generates corrosive gas of attacking the polarizer at high temperature and the latter causes circuit break by electro-chemical reaction.
- (6) Do not touch, push or rub the exposed polarizers with glass, tweezers or anything harder than HB pencil lead. And please do not rub with dust clothes with chemical treatment.  
Do not touch the surface of polarizer for bare hand or greasy cloth. (Some cosmetics are detrimental to the polarizer.)
- (7) When the surface becomes dusty, please wipe gently with absorbent cotton or other soft materials like chamois soaked with petroleum benzene. Normal-hexane is recommended for cleaning the adhesives used to attach front / rear polarizers. Do not use acetone, toluene and alcohol because they cause chemical damage to the polarizer.
- (8) Wipe off saliva or water drops as soon as possible. Their long time contact with polarizer causes deformations and color fading.
- (9) Do not open the case because inside circuits do not have sufficient strength.

### 9.2 OPERATING PRECAUTIONS

- (1) The spike noise causes the mis-operation of circuits. It should be lower than following voltage :  
 $V = \pm 200\text{mV}$  (Over and under shoot voltage).
- (2) Response time depends on the temperature. (In lower temperature, it becomes longer.)
- (3) Brightness depends on the temperature. (In lower temperature, it becomes lower.)  
And in lower temperature, response time (required time that brightness is stable after turned on) becomes longer.
- (4) Be careful for condensation at sudden temperature change. Condensation makes damage to polarizer or electrical contacted parts. And after fading condensation, smear or spot will occur.
- (5) When fixed patterns are displayed for a long time, remnant image is likely to occur.
- (6) A module has high frequency circuit. If you need to shield the electromagnetic noise, please do in yours. When a Back-light unit is operating, it sounds. If you need to shield the noise, please do in yours.

### 9.3 ELECTROSTATIC DISCHARGE CONTROL

Since a module is composed of electronic circuits, it is not strong to electrostatic discharge. Make certain that treatment persons are connected to ground through wrist band etc . And don't touch interface pin directly.

### 9.4 PRECAUTIONS FOR STRONG LIGHT EXPOSURE

Strong light exposure causes degradation of polarizer and color filter.

### 9.5 STORAGE

When storing modules as spares for a long time, the following precautions are necessary.

- (1) Store them in a dark place. Do not expose the module to sunlight or fluorescent light. Keep the temperature between 5□ and 35□ at normal humidity.
- (2) The polarizer surface should not come in contact with any other object.  
It is recommended that they be stored in the container in which they were shipped.

### 9.6 HANDLING PRECAUTIONS FOR PROTECTION FILM

- (1) When the protection film is peeled off, static electricity is generated between the film and polarizer.  
This should be peeled off slowly and carefully by people who are electrically grounded and with well ion- blown equipment or in such a condition, etc..
- (2) The protection film is attached to the polarizer with a small amount of glue. If some stress is applied to rub the protection film against the polarizer during the time you peel off the film, the glue is apt to remain on the polarizer.  
Please carefully peel off the protection film without rubbing it against the polarizer.
- (3) When the module with protection film attached is stored for a long time, sometimes there remains a very small amount of glue still on the polarizer after the protection film is peeled off.
- (4) You can remove the glue easily. When the glue remains on the polarizer surface or its vestige is recognized, please wipe them off with absorbent cotton waste or other soft material like chamois soaked with normal-hexane.



**Product Specification**

**A-1 Optical Characteristic Measurement Equipment and Method**

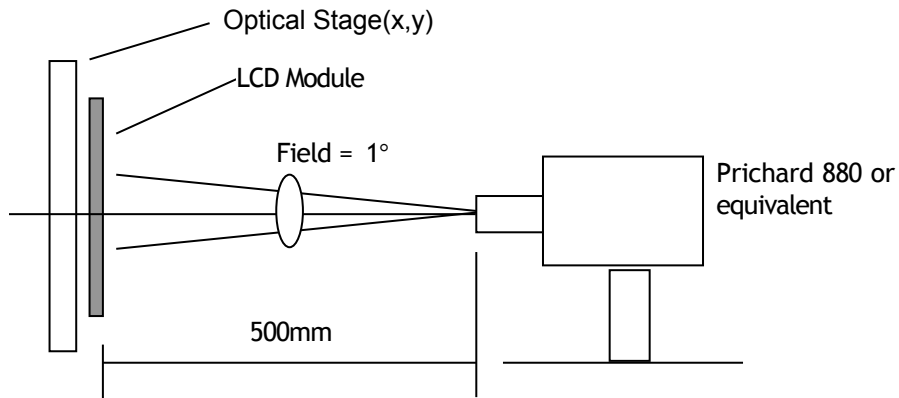

**A-2 Luminance**

<measuring points for luminance variation

<measuring point for surface luminance >

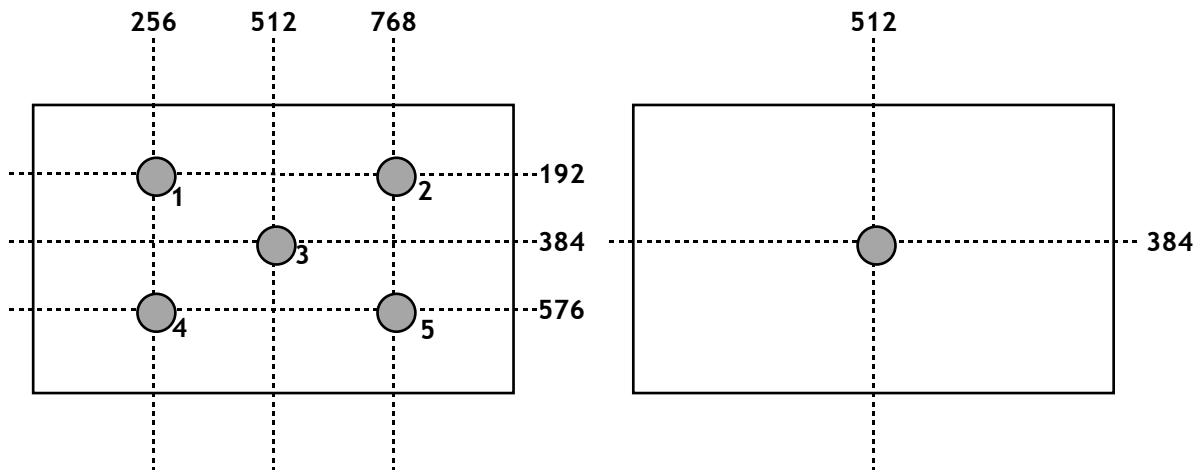

**A-3 Response Time**

The response time is defined as the following figure and shall be measured by switching the input signal for "black" and "white".

Product Specification

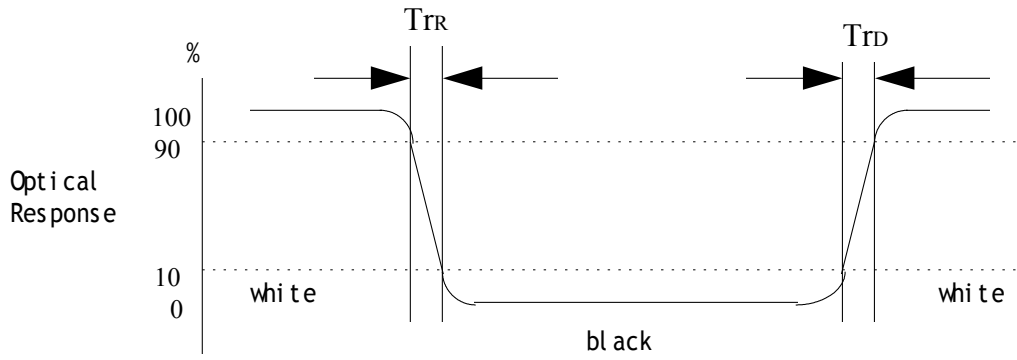

**Product Specification**

**A-4 Viewing angle**

<Definition of viewing angle range>

