

DATA DISPLAY AG

**LP141X6-A1IB
14.1" XGA TFT LCD**

**PRELIMINARY
SPECIFICATION**

1. GENERAL DESCRIPTION

The LP141X6-A1IB is a Color Active Matrix Liquid Crystal Display with an integral Cold Cathode Fluorescent Lamp(CCFL) back light system. The matrix employs a-Si Thin Film Transistor as the active element. It is a transmissive type display operating in the normally white mode. This TFT-LCD has a 14.1 inch diagonally measured active display area with XGA resolution(768 vertical by 1024 horizontal pixel array). Each pixel is divided into Red, Green and Blue sub-pixels or dots which are arranged in vertical stripes. Gray scale or the brightness of the sub-pixel color is determined with a 6-bit gray scale signal for each dot, thus, presenting a palette of more than 262,144 colors. The LP141X6-A1IB has been designed to apply the interface method that enables low power, high speed low EMI. Flat Link must be used as a LVDS(Low Voltage Differential Signaling) chip. The LP141X6-A1IB is intended to support applications where thin thickness, low power are critical factors and graphic displays are important. In combination with the vertical arrangement of the sub-pixels, the LP141X6-A1IB characteristics provide an excellent flat panel display for office automation products such as mobile industrial computers.

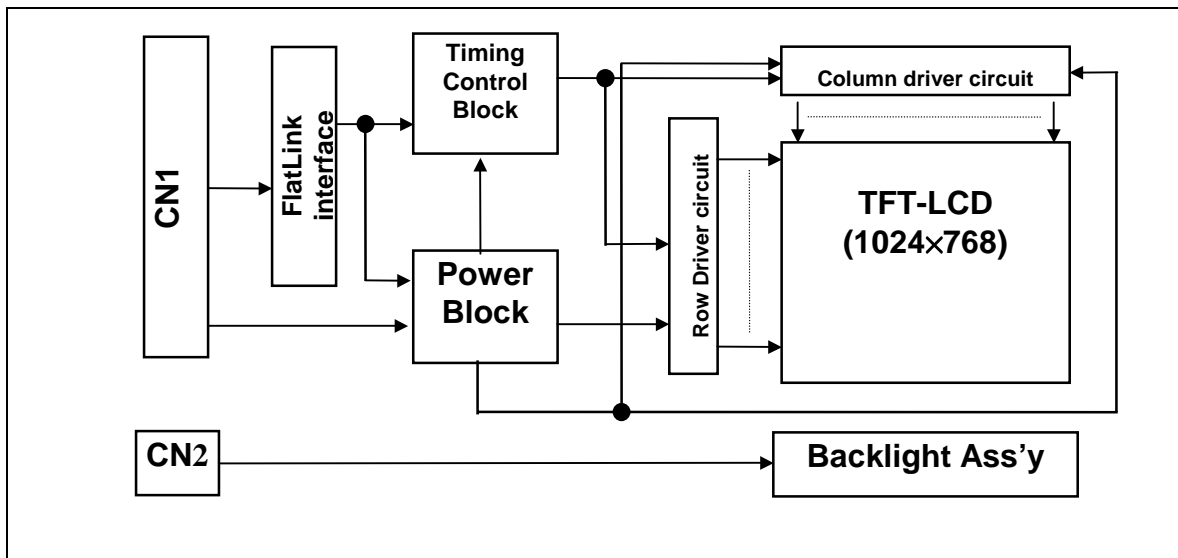

General Features

Active screen size	14.1 inches (33.78 cm) diagonal
Outline dimensions	298.5 (H) × 227.5 (V) × 5.7 (D) mm (typ)
Pixel pitch	0.279 mm × 0.279 mm
Pixel format	1024 horiz. By 768 vert. Pixel RGB stripe arrangement
Color depth	6-bit, 262,144 colors
Luminance, White	150 cd/m ² (typ)
Power Consumption	Total 4.54 Watt (typ)
Weight	500g (typ)
Display operating mode	transmissive mode, normally white
Surface treatments	hard coating(3H), anti-glare treatment of the front polarizer

2. ABSOLUTE MAXIMUM RATINGS

The following are maximum values which, if exceeded, may cause faulty operation or damage to the unit.

Table 1 ABSOLUTE MAXIMUM RATINGS

Parameter	Symbol	Values		Units	Notes
		Min.	Max.		
Power Input Voltage	V_{CC}	-0.3	+3.6	Vdc	at 25°
Operating Temperature	T_{OP}	0	+50	°C	1,2
Storage Temperature	T_{ST}	-20	+60	°C	1,2

Note 1: Temperature at 5 mm above display center of LCD Module.

$T_a \leq 40^\circ\text{C}$: 90 % RH max

$T_a > 40^\circ\text{C}$: Absolute Humidity shall be less than $T_a = 40^\circ$ 90 % RH.

These shall be no dew condensation.

Note 2: Humidity Min. 5% RH, Max. 90% RH

3. ELECTRICAL SPECIFICATIONS

3.1 Electrical Characteristics

The LP141X6-A1IB requires two power inputs. One is employed to power the LCD electronics and to drive the TFT array and liquid crystal. The second input which powers the CCFL, is typically generated by an inverter. The inverter is an external unit to the LCD.

Table 2 ELECTRICAL CHARACTERISTICS

Parameter	Symbol	Values			Units	Notes
		Min.	Typ.	Max.		
MODULE:						
Power Supply Input Voltage	V_{CC}	3.0	3.3	3.6	Vdc	
Power Supply Input Current	I_{CC}	-	0.275	0.315	A	1
Differential Impedance	Z_m	90	100	110	ohm	2
Power Consumption	P_c	-	0.91	1.04	Watts	1
Rush current	I_{RUSH}	-	1.0	1.5	A	3
LAMP						
Operating Voltage	V_{BL}	680	725	850	V_{RMS}	4
Operating Current	I_{BL}	3.0	5.0	6.0	mA	
Established Starting Voltage						5
at 25°C		-	-	1170	V_{RMS}	
at 0°C		-	-	1450	V_{RMS}	
Operating Frequency	f_{BL}	40	60	80	kHz	
Power Consumption	P_{BL}	-	3.63	4.08	Watts	6
Half Life Time		10,000	15,000	-	Hrs	7

Notes 1: The specified current and power consumption are under the $V_{cc} = 3.3V$, 25°C, $f_v = 60$ Hz condition whereas Black pattern is displayed.

Notes 2: This impedance value is needed to proper display and measured form LVDS Tx to the mating connector.

Notes 3: The duration of rush current is about 20 ms.

Notes 4: The variance of the voltage is $\pm 10\%$.

Notes 5: The transformer output voltage in the inverter must be high considering to the loss of the ballast capacitor in the inverter.

Notes 6: The lamp power consumption shown above does not include loss of external inverter.

Notes 7: The life time is determined as the time at which brightness of lamp is 50 % compare to that of initial value at the typical lamp current

3.2 Interface Connections

This LCD employs two interface connections, a 20 pin connector is used for the module electronics and the other connector is used for the integral backlight system. The electronics interface connector is a model FI-SEB-20P-HF manufactured by JAE or equivalent. The pin configuration for the connector is shown in the table below.

Table 3 MODULE CONNECTOR PIN CONFIGURATION (LVDS) [CN1]

Pin	Symbol	Description	Notes
1	VCC	Power (3.3V)	1. Interface chips 1.1 LCD: KZ4E038C12CFP (Thine) (THC63LVDF64A core + Timing Controller) 1.2 System: THC63LVDM63A (Thine) * Pin to pin compatible with TI LVDS 2. Connector 2.1 LCD: GT122-20P-R (LG CABLE) 2.2 Mating: FI-WEB21P-HF (JAE) 2.3 Connector pin arrangement
2	VCC	Power (3.3V)	
3	GND	Ground	
4	GND	Ground	
5	A0M	Difference Signal	
6	A0P	Difference Signal	
7	GND	Ground	
8	A1M	Difference Signal	
9	A1P	Difference Signal	
10	GND	Ground	
11	A2M	Difference Signal	
12	A2P	Difference Signal	
13	GND	Ground	
14	CLKM	Difference Signal	
15	CLKP	Difference Signal	
16	GND	Ground	
17	NC	No Connection	
18	NC	No Connection	
19	GND	Ground	
20	GND	Ground	

No. 1-20



CN1

Viewing on Display side CN2

The backlight interface connector is a model BHSR-02VS-1, manufactured by JST. The mating connector part number is SM02B-BHSS-1 or equivalent. The pin configuration for the connector is shown in the table below.

Table 4 BACKLIGHT CONNECTOR PIN CONFIGURATION [CN2]

Pin	Symbol	Description	Notes
1	HV	High voltage input	1
2	LV	Low voltage input	2

Notes 1: The high voltage input terminal is colored white.

Notes 2: The low voltage input terminal is colored black.

Table 5 REQUIRED SIGNAL ASSIGNMENT FOR FLATLINK TRANSMITTER

Pin #	Pin Name	Require Signals	Pin #	Pin Name	Require Signals
1	D4	R4	48	D3	R3
2	Vcc	Vcc	47	D2	R2
3	D5	R5	46	GND	GND
4	D6	G0	45	D1	R1
5	GND	GND	44	D0	R0
6	D7	G1	43	NC	NC
7	D8	G2	42	LVDS GND	LVDS GND
8	Vcc	Vcc	41	Y0M	A0M
9	D9	G3	40	Y0P	A0P
10	D10	G4	39	Y1M	A1M
11	GND	GND	38	Y1P	A1P
12	D11	G5	37	LVDS Vcc	LVDS Vcc
13	D12	B0	36	LVDS GND	LVDS GND
14	NC	NC	35	Y2M	A2M
15	D13	B1	34	Y2P	A2P
16	D14	B2	33	CLKOUTM	CLKM
17	GND	GND	32	CLKOUTP	CLKP
18	D15	B3	31	LVDS GND	LVDS GND
19	D16	B4	30	PLLGND	PLL GND
20	D17	B5	29	PLLVcc	PLL Vcc
21	Vcc	Vcc	28	PLLGND	PLL GND
22	D18	HSYNC	27	SHDN	SHDN
23	D19	VSYNC	26	CLKIN	Dclk
24	GND	GND	25	D20	DE (Data Enable)

Notes: Refer to LVDS Transmitter Data Sheet for detail descriptions.

3.3 Signal Timing Specifications

This is the signal timing required at the input of the LVDS Transmitter. All of the interface signal timing should be satisfied with the following specifications for it's proper operation.

Table 6 Timing Table

	ITEM	SYMBOL	MIN.	TYP.	MAX.	UNIT	NOTE
Dclk	Period	t_{CLK}	14.7	15.4	16.1	ns	65MHz(Typ)
Hsync	Period	t_{HP}	1206	1344	1364	t_{CLK}	
	Width-Active	t_{WH}	16	136	240		
Vsync	Period	t_{VP}	780	806	830	t_{HP}	
	Frequency	f_V	-	60	-	Hz	
	Width-Active	t_{WV}	1	6	24	t_{HP}	
DE (Data Enable)	Horizontal Back Porch	t_{HBP}	10	160	-	t_{CLK}	
	Horizontal Front Porch	t_{HFP}	10	24	-		
	Vertical Back Porch	t_{VBP}	2	29	-	t_{HP}	
	Vertical Front Porch	t_{VFP}	1	3	-		

3.4 Signal Timing Wave forms

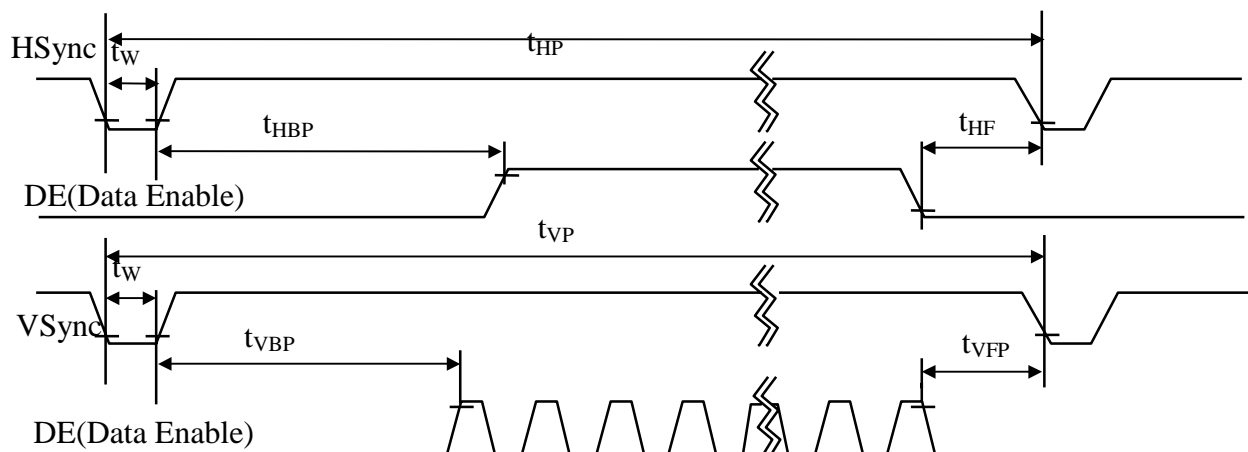
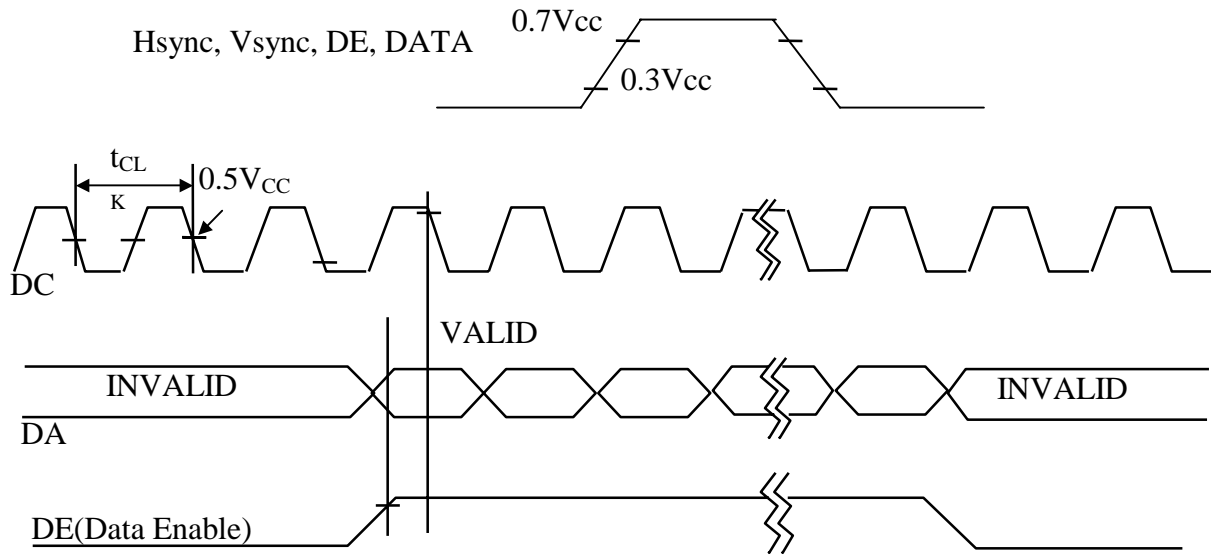

3.5 Color Input Data Reference

The brightness of each primary color (red, green and blue) is based on the 6-bit gray scale data input for the color; the higher the binary input, the brighter the color. The table below provides a reference for color versus data input.

Table 7 COLOR DATA REFERENCE

Color		Input Color Data																	
		Red						Green						Blue					
		MSB		LSB				MSB		LSB				MSB		LSB			
		R5	R4	R3	R2	R1	R0	G5	G4	G3	G2	G1	G0	B5	B4	B3	B2	B1	B0
Basic Colors	Black	0	0	0	0	0	0	0	0	0	0	0	0	0	0	0	0	0	0
	Red(63)	1	1	1	1	1	1	0	0	0	0	0	0	0	0	0	0	0	0
	Green(63)	0	0	0	0	0	0	1	1	1	1	1	1	0	0	0	0	0	0
	Blue(63)	0	0	0	0	0	0	0	0	0	0	0	0	1	1	1	1	1	1
	Cyan	0	0	0	0	0	0	1	1	1	1	1	1	1	1	1	1	1	1
	Magenta	1	1	1	1	1	1	0	0	0	0	0	0	1	1	1	1	1	1
	Yellow	1	1	1	1	1	1	1	1	1	1	1	1	0	0	0	0	0	0
	White	1	1	1	1	1	1	1	1	1	1	1	1	1	1	1	1	1	1
Red	Red(00) Dark	0	0	0	0	0	0	0	0	0	0	0	0	0	0	0	0	0	0
	Red(01)	0	0	0	0	0	1	0	0	0	0	0	0	0	0	0	0	0	0
	Red(02)	0	0	0	0	1	0	0	0	0	0	0	0	0	0	0	0	0	0
	:	:	:	:	:	:	:	:	:	:	:	:	:	:	:	:	:	:	
	Red(61)	1	1	1	1	0	1	0	0	0	0	0	0	0	0	0	0	0	0
	Red(62)	1	1	1	1	1	0	0	0	0	0	0	0	0	0	0	0	0	0
	Red(63) Bright	1	1	1	1	1	1	0	0	0	0	0	0	0	0	0	0	0	0
Green	Green(00)Dark	0	0	0	0	0	0	0	0	0	0	0	0	0	0	0	0	0	0
	Green(01)	0	0	0	0	0	0	0	0	0	0	0	1	0	0	0	0	0	0
	Green(02)	0	0	0	0	0	0	0	0	0	0	1	0	0	0	0	0	0	0
	:	:	:	:	:	:	:	:	:	:	:	:	:	:	:	:	:	:	
	Green(61)	0	0	0	0	0	0	1	1	1	1	0	1	0	0	0	0	0	0
	Green(62)	0	0	0	0	0	0	1	1	1	1	1	0	0	0	0	0	0	0
	Green(63) Bright	0	0	0	0	0	0	1	1	1	1	1	1	0	0	0	0	0	0
Blue	Blue(00) Dark	0	0	0	0	0	0	0	0	0	0	0	0	0	0	0	0	0	0
	Blue(01)	0	0	0	0	0	0	0	0	0	0	0	0	0	0	0	0	0	1
	Blue(02)	0	0	0	0	0	0	0	0	0	0	0	0	0	0	0	0	1	0
	:	:	:	:	:	:	:	:	:	:	:	:	:	:	:	:	:	:	
	Blue(61)	0	0	0	0	0	0	0	0	0	0	0	0	1	1	1	1	0	1
	Blue(62)	0	0	0	0	0	0	0	0	0	0	0	0	1	1	1	1	1	0
	Blue(63) Bright	0	0	0	0	0	0	0	0	0	0	0	0	1	1	1	1	1	1

3.6 Power Sequence

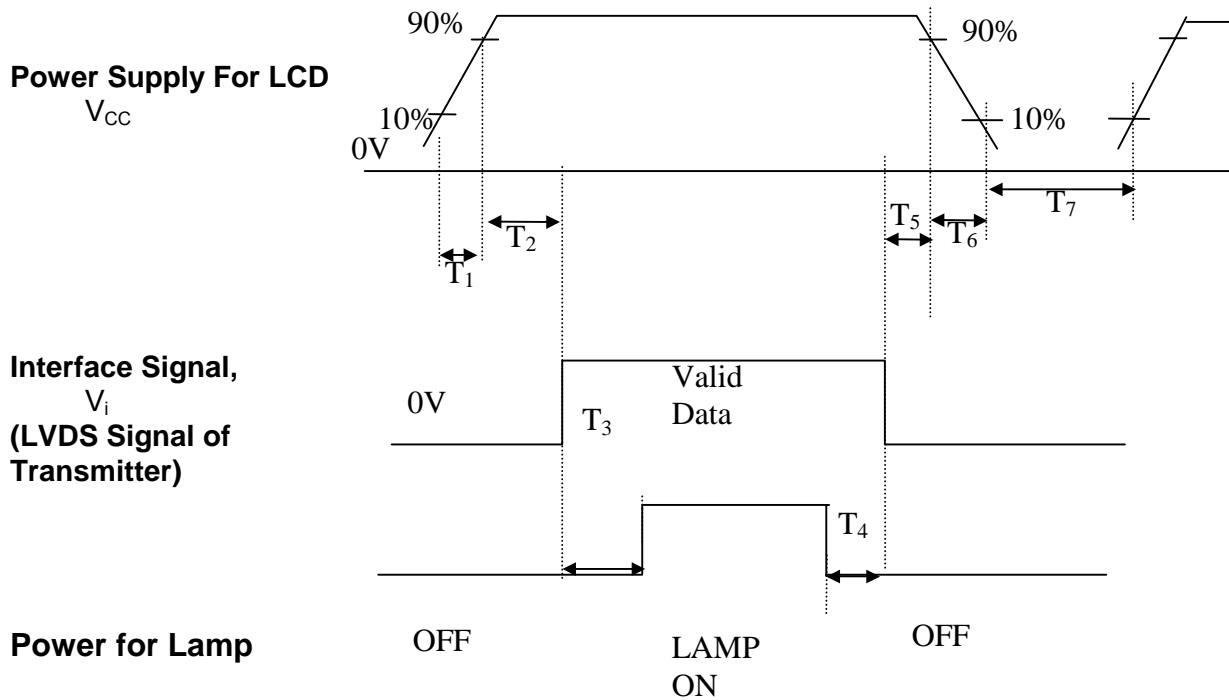

Parameter	Values			Units
	Min.	Typ.	Max.	
T_1	0.01	-	10	ms
T_2	0.01	-	20	ms
T_3	50	-	-	ms
T_4	50	-	-	ms
T_5	0.01	-	20	ms
T_6	0.01	-	20	ms
T_7	1	-	-	s

Notes 1: Please avoid floating state of interface signal at invalid period.

Notes 2: When the interface signal is invalid, be sure to pull down the power supply for LCD V_{CC} to 0V.

Notes 3: Lamp power must be turn on after power supply for LCD and interface signal are valid.

3.7 Vcc Dip Condition

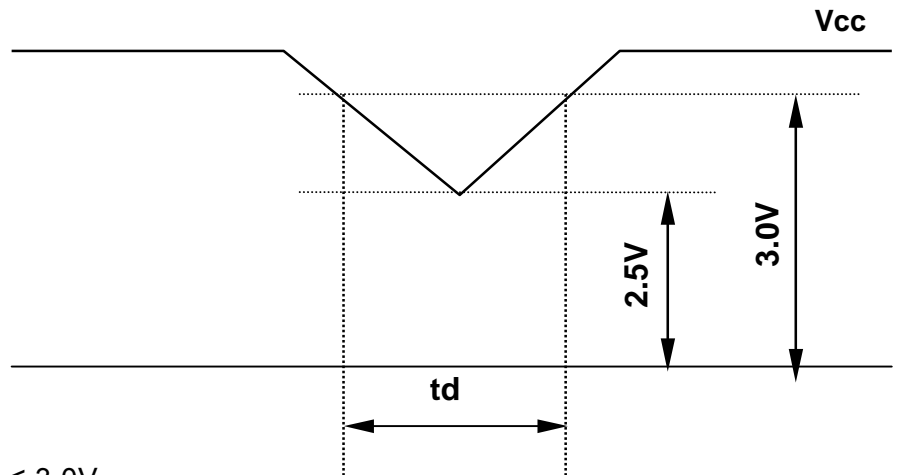

- 1) $2.5V \leq V_{cc} \leq 3.0V$
 $t_d \leq 20ms$
- 2) $V_{cc} < 2.5V$
Vcc-dip conditions should also follow the Power Up/Down conditions for supply voltage.

Notes: This phenomenon is caused by row driver IC initialization after power on (1 vertical period) .

4. OPTICAL SPECIFICATIONS

Optical characteristics are determined after the unit has been 'ON' and stable for approximately 30 minutes in a dark environment at 25°C. The values specified are at an approximate distance 50cm from the LCD surface at a viewing angle of Φ and θ equal to 0°.

Appendix A -1 presents additional information concerning the measurement equipment and method.

Table 8 OPTICAL CHARACTERISTICS (Ta=25°C, Vcc=3.3 V, f_V =60 Hz, Dclk=65 MHz, I_{BL}=6.0 mA)

Parameter	Symbol	Values			Units	Notes
		Min.	Typ.	Max.		
Contrast Ratio	CR	150	250	-		1
Surface Luminance, white	L _{WH}	-	150	-	cd/m ²	2
Luminance Variation	δWHITE	-	1.25	1.45		3
Response Time	Tr				msec	4
Rise Time	Tr _R	-	20	40		
Delay Time	Tr _D	-	30	50		
CIE Color Coordinates						
Red	X _R	-	TBD	-		
	Y _R	-	TBD	-		
Green	X _G	-	TBD	-		
	Y _G	-	TBD	-		
Blue	X _B	-	TBD	-		
	Y _B	-	TBD	-		
White	X _W	-	TBD	-		
	Y _W	-	TBD	-		
Viewing Angle					degree	5
x axis, right (Φ=0°)	θ _{xr}	40	-	-		
x axis, left (Φ=180°)	θ _{xl}	40	-	-		
y axis, up (Φ=90°)	θ _{yu}	10	-	-		
y axis, down (Φ=270°)	θ _{yd}	30	-	-		
Gray Scale		-	-	-		6

Notes 1: Contrast Ratio (CR) is defined mathematically as :

$$\text{Contrast Ratio} = \frac{\text{Surface Luminance with all white pixels}}{\text{Surface Luminance with all black pixels}}$$

Notes 2: Surface luminance is the center point across the LCD surface 50cm from the surface with all pixels displaying white. For more information see Appendix A - 2.

Notes 3: The variation in surface Luminance, WHITE is determined by measuring L_{ON} at each test position 1 through 9, and then dividing the maximum L_{ON} of 9 points luminance by minimum L_{ON} of 9 points luminance. For more information see Appendix A - 2.

$$\text{WHITE Maximum} (L_{ON1}, L_{ON2}, \dots L_{ON9}) \div \text{Minimum} (L_{ON1}, L_{ON2}, \dots L_{ON9})$$

Notes 4: Response time is the time required for the display to transition from white to black (Rise Time, Tr_R) and from black to white (Delay Time, Tr_D). For additional information see Appendix A - 3.

Notes 5: Viewing angle is the angle at which the contrast ratio is greater than 10. The angles are determined for the horizontal or x axis and the vertical or y axis with respect to the z axis which is normal to the LCD surface. For more information see Appendix A - 4

Notes 6: Gray scale specification.

Gray Level	Luminance(%) (typ)
L0	0.4
L7	1.8
L15	4.6
L23	10.0
L31	21.0
L39	37.0
L47	59.5
L55	82.0
L63	100

5. MECHANICAL CHARACTERISTICS

The contents provide general mechanical characteristics for the model LP141X6-A11B LCD. In addition, the figures in the next page are detailed mechanical drawings of the LCD.

Outside dimensions:

Horizontal	298.5 + 0.3, -0.3 mm
Vertical	227.5 + 0.3, -0.3 mm
Depth	5.7 ± 0.3 mm

Bezel area:

Horizontal	289.3 + 0.3, -0.5 mm
Vertical	217.9 + 0.3, -0.3 mm

Active Display area:

Horizontal	285.7 mm
Vertical	214.3 mm

Weight (approximate)

500 g (typ), 510 g (max)

Surface Treatment:

Hard coating 3 H.
Anti-glare treatment of the front polarizer

< FRONT VIEW >

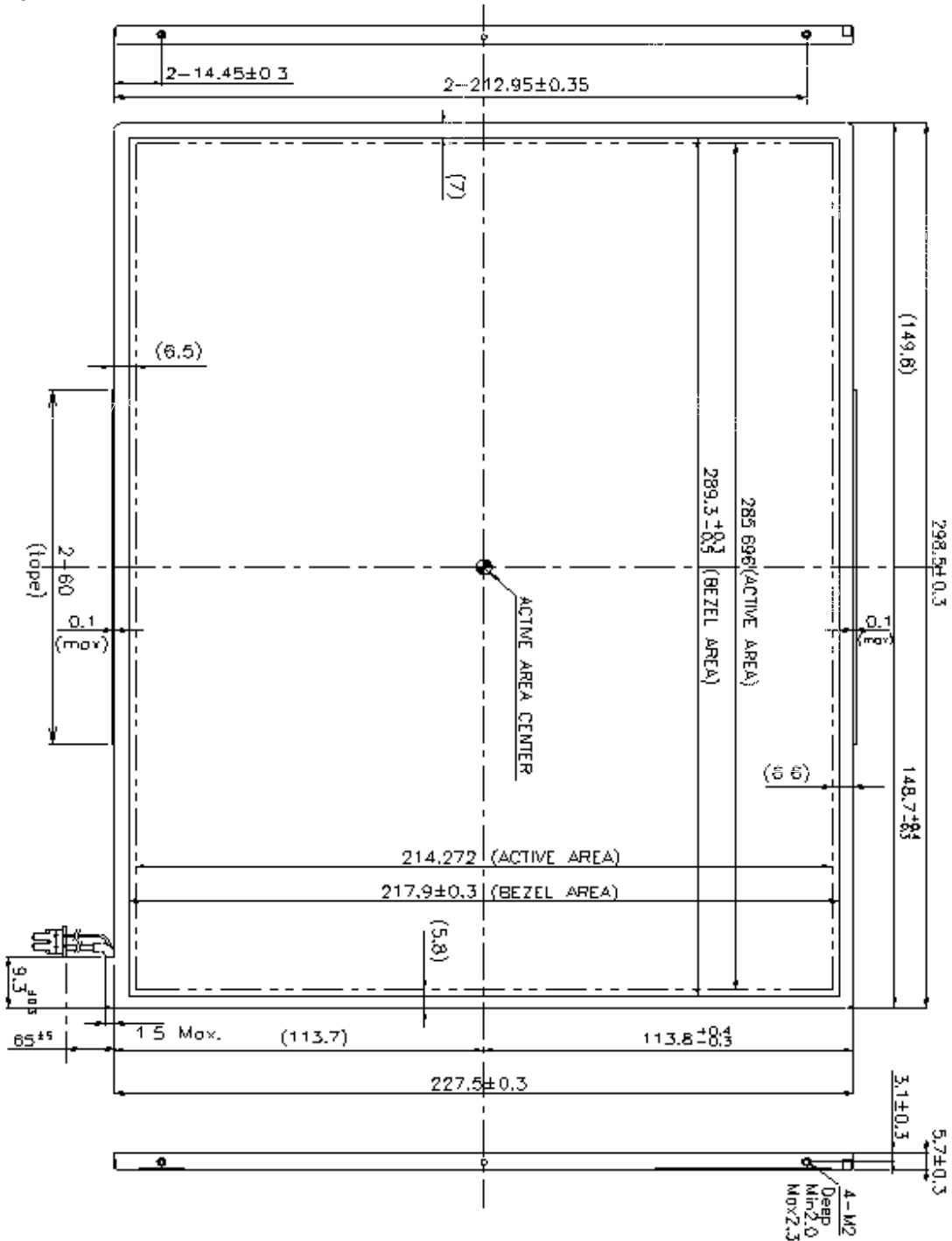

Notes 1: Unspecified dimensional tolerance are $\pm 0.5\text{mm}$

Detail description of side mounting screw

Structure of joint

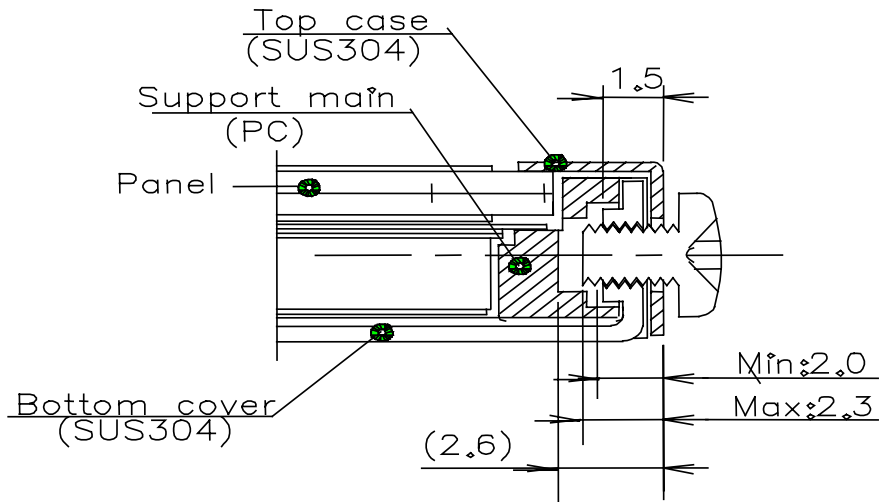

- * Mounting Screw depth : 2.0 [mm] Min. 2.3 [mm] Max.
- * Torque : 1.3 ~ 1.5 [kgf cm]

Notes 1: Mounting Screw depth: Min. 2.0 [mm], Max. 2.3 [mm]
 Notes 2: Torque: 2.8 ± 0.3 [kgf·cm]

6. RELIABILITY

Environment test condition

No.	Test Item	Conditions
1	High temperature storage test	Ta = 60°C 240 h
2	Low temperature storage test	Ta = -20°C 240 h
3	High temperature operation test	Ta = 50°C 50% RH 240 h
4	Low temperature operation test	Ta = 0° 240 h
5	Vibration test (non-operating)	Sine wave, 10 ~ 500 ~ 10 Hz, 1.5 G, 0.37 oct/min, 3 axis, 1 hour/axis
6	Shock test (non-operating)	Half sine wave, 110 G, 6 ms, one shock of each six faces (i.e. run 110G 6 ms for all six faces.) Square wave, 50 G, 18 ms (for packing)
7	Altitude operating storage/shipment	0 - 10,000 feet (3048 m) 0 - 40,000 feet (12192 m)

Result Evaluation Criteria

There should be no change which might affect the practical display function when the display quality test is conducted under normal operating condition.

- ON/OFF Cycle: The display module will be capable of being operated over 24,000 ON/OFF cycles (Lamp power & Vcc ON/OFF)
- Mean Time Between Failure: The LCD Panel and interface board assembly (excluding the CCFTs) have a mean time between failures of 30,000 hours with a confidence level 90%.

7. INTERNATIONAL STANDARDS

7.1 Safety

- a) UL 1950 Third Edition, Underwriters Laboratories, Inc. Jan. 28, 1995.
Standard for Safety of Information Technology Equipment Including Electrical Business Equipment.
- b) CAN/CSA C22.2 No. 950-95 Third Edition, Canadian Standards Association, Jan. 28, 1995. Standard for Safety of Information Technology Equipment Including Electrical Business Equipment.
- c) EN 60950 : 1992 + A1 : 1993 + A2 : 1993 + A3 : 1995 + A4 : 1997 + A11 : 1997
IEC 950 : 1991 + A1 : 1992 + A2 : 1993 + A3 : 1995 + A4 : 1996
European Committee for Electrotechnical Standardization (CENELEC)
EUROPEAN STANDARD for Safety of Information Technology Equipment Including Electrical Business Equipment.

7.2 EMC

- a) ANSI C63.4 "Methods of Measurement of Radio-Noise Emissions from Low-Voltage Electrical and Electronic Equipment in the Range of 9kHz to 40GHz." American National Standards Institute(ANSI),1992.
- b) C.I.S.P.R "Limits and Methods of Measurement of Radio Interference Characteristics of Information Technology Equipment." International Special Committee on Radio Interference
- c) EN 55022 "Limits and Methods of Measurement of Radio Interference Characteristics of Information Technology Equipment." European Committee for Electrotechnical Standardization (CENELEC),1988

8. PACKING

8.1 Designation of Lot Mark

a) Lot Mark

A	B	C	D	E	F	G	H	I	J	K	L	M
---	---	---	---	---	---	---	---	---	---	---	---	---

A, B, C: INCH CODE
 D: YEAR
 E: MONTH
 F,G: PANEL FACTORY
 H: MODULE LINE
 I, J, K, L, M: SERIAL NO

Note 1: YEAR(D)

YEAR	99	00	01	02	03	04	05	06	07	08	09
Mark	9	0	1	2	3	4	5	6	7	8	9

Note 2: MONTH(E)

MONTH	Jan	Feb	Mar	Apr	May	Jun	Jul	Aug	Sep	Oct	Nov	Dec
Mark	1	2	3	4	5	6	7	8	9	0	A	B

Note 3: MODULE LINE(H)

LINE	1	2	3	4	5	6	7	8	9	10	11	12	13
Mark	1	2	3	4	5	6	7	8	9	A	B	C	D

b) Location of Lot Mark

Serial No. is printed on the label. The label is attached to the backside of the LCD module.

This is subject to change without prior notice.

8.2 Packing Form

- a) Package quantity in one box: 10 PCS
- b) Box Size: 374mm X 329mm X 311mm

9. PRECAUTIONS

Please pay attention to the followings when you use this TFT LCD module.

9.1 MOUNTING PRECAUTIONS

- (1) You must mount a module using holes arranged in four corners or four sides.
- (2) You should consider the mounting structure so that uneven force (ex. Twisted stress) is not applied to the module.
And the case on which a module is mounted should have sufficient strength so that external force is not transmitted directly to the module.
- (3) Please attach a transparent protective plate to the surface in order to protect the polarizer.
Transparent protective plate should have sufficient strength in order to resist external force.
- (4) You should adopt radiation structure to satisfy the temperature specification.
- (5) Acetic acid type and chlorine type materials for the cover case are not desirable because the former generates corrosive gas of attacking the polarizer at high temperature and the latter causes circuit break by electro-chemical reaction.
- (6) Do not touch, push or rub the exposed polarizers with glass, tweezers or anything harder than HB pencil lead. And Please do not rub with dust clothes with chemical treatment.
Do not touch the surface of polarizer for bare hand or greasy cloth. (Some cosmetics are detrimental to the polarizer.)
- (7) When the surface becomes dusty, please wipe gently with absorbent cotton or other soft materials like chamois soaked with petroleum benzene. Normal-hexane is recommended for cleaning the adhesives used to attach front / rear polarizers. Do not use acetone, toluene and alcohol because they cause chemical damage to the polarizer.
- (8) Wipe off saliva or water drops as soon as possible. Their long time contact with polarizer causes deformations and color fading.
- (9) Do not open the case because inside circuits do not have sufficient strength.

9.2 OPERATING PRECAUTIONS

- (1) The spike noise causes the mis-operation of circuits. It should be lower than following voltage: $V = \pm 200\text{mV}$ (Over and under shoot voltage).
- (2) Response time depends on the temperature. (In lower temperature, it becomes longer.)
- (3) Brightness depends on the temperature. (In lower temperature, it becomes lower.)

And in lower temperature, response time (required time that brightness is stable after turned on) becomes longer.

- (4) Be careful for condensation at sudden temperature change. Condensation makes damage to polarizer or electrical contacted parts. And after fading condensation, smear or spot will occur.
- (5) When fixed patterns are displayed for a long time, remnant image is likely to occur.
- (6) A module has high frequency circuit. If you need to shield the electromagnetic noise, please do in yours. When a Back-light unit is operating, it sounds. If you need to shield the noise, please do in yours.

9.3 ELECTROSTATIC DISCHARGE CONTROL

Since a module is composed of electronic circuits, it is not strong to electrostatic discharge. Make certain that treatment persons are connected to ground through wrist band etc. And don't touch interface pin directly.

9.4 PRECAUTIONS FOR STRONG LIGHT EXPOSURE

Strong light exposure causes degradation of polarizer and color filter.

9.5 STORAGE

When storing modules as spares for a long time, the following precautions are necessary.

- (1) Store them in a dark place. Do not expose the module to sunlight or fluorescent light. Keep the temperature between 5° and 35° at normal humidity.
- (2) The polarizer surface should not come in contact with any other object. It is recommended that they be stored in the container in which they were shipped.

9.6 HANDLING PRECAUTIONS FOR PROTECTION FILM

- (1) When the protection film is peeled off, static electricity is generated between the film and polarizer.
This should be peeled off slowly and carefully by people who are electrically grounded and with well ion- blown equipment or in such a condition, etc..
- (2) The protection film is attached to the polarizer with a small amount of glue. If some stress is applied to rub the protection film against the polarizer during the time you peel off the film, the glue is apt to remain on the polarizer.
Please carefully peel off the protection film without rubbing it against the polarizer.
- (3) When the module with protection film attached is stored for a long time, sometimes there remains a very small amount of glue still on the polarizer after the protection film is peeled off.
- (4) You can remove the glue easily. When the glue remains on the polarizer surface or its vestige is recognized, please wipe them off with absorbent cotton waste or other soft material like chamois soaked with normal-hexane.

A-1 Optical Characteristic Measurement Equipment and Method

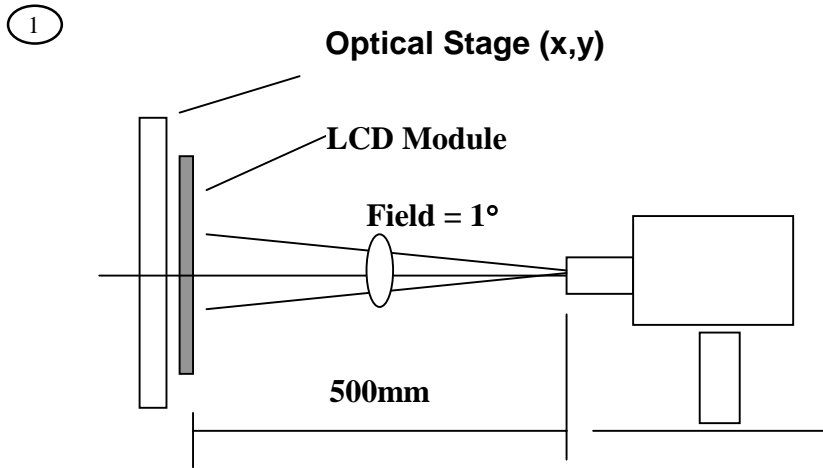

A-2 Luminance

< Measuring point for surface luminance >

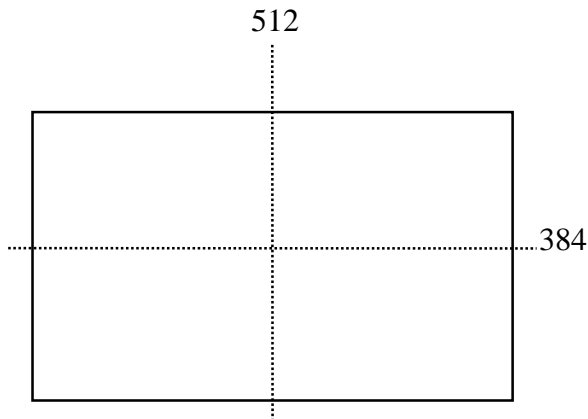

< Measuring point for luminance variation >

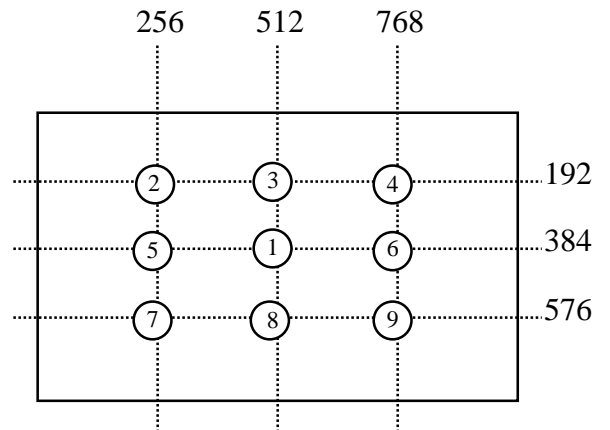

A-3 Response Time

The response time is defined as the following figure and shall be measured by switching the input signal for "black" and "white".

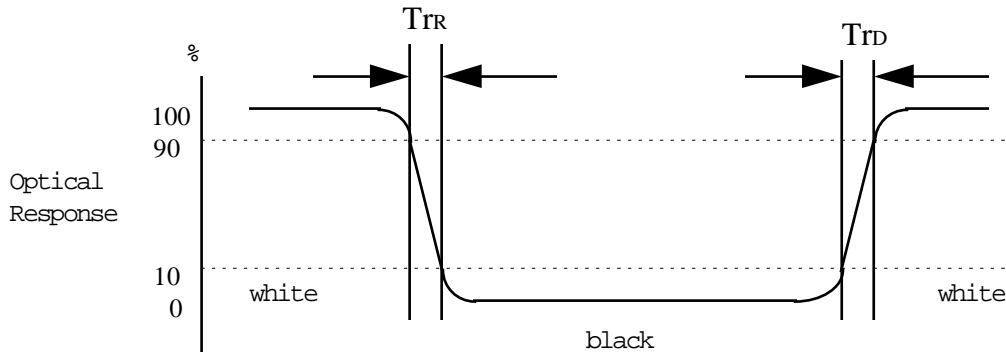

A-4 Viewing angle

<Definition of viewing angle range>

