

ECR #	REV. HIST.	DESCRIPTION	APPROVED	DATE
	A	First release	Hiroaki Sakita	10/25/2000

TECHNICAL SPECIFICATION
AA150XA01B
15.0-INCH XGA
FOR
INDUSTRIAL APPLICATIONS

APPROVALS		DATE	 MITSUBISHI ELECTRIC TFT-LCD MODULE 15.0-INCH XGA COLOR AA150XA01B	
MEUS ENG.	HIROAKI SAKITA	10/25/2000		
MEUS MKTG.	DALE MAUNU			
MITSUBISHI/ADI				
SIZE	MITSUBISHI ELECTRIC SPECIFICATION		REV.	
A	AA150XA01B		A	SHEET 1 OF 22

TABLE OF CONTENTS

No.	ITEM	PAGE
—	COVER	1
—	TABLE OF CONTENTS	2
1	OVERVIEW	3
2	ABSOLUTE MAXIMUM RATINGS	4
3	ELECTRICAL CHARACTERISTICS	4, 5, 6
4	INTERFACE PIN CONNECTION	7, 8
5	INTERFACE TIMING	9, 10, 11, 12
6	BLOCK DIAGRAM	13
7	MECHANICAL SPECIFICATION	14, 15
8	OPTICAL CHARACTERISTICS	16, 17
9	RELIABILITY TEST CONDITION	18
10	INSPECTION STANDARDS	19, 20
11	HANDLING PRECAUTIONS FOR TFT-LCD MODULE	21, 22

1. OVERVIEW

1.1. Description: The AA150XA01B is a 15.0-inch color TFT-LCD (Thin Film Transistor Liquid Crystal Display) module composed of a LCD panel, driver ICs, a control circuit, and a backlight. Input power voltage is 5.0 V., not including power for the backlight. Both 3.3V-CMOS and 5.0V-CMOS levels are acceptable for logic input. Data and control signal interface is digital CMOS, and transmitted at a typical frequency of 32.5 MHz. Data is transmitted at a rate of two pixels per clock cycle. The display module supports 16.7 million colors by applying 24 bits digital data (8 bits per sub-pixel, RGB). The display module resolution is 1024 × 768 pixels. Inverter for backlight is not included in this module.

1.2. General specifications summary table:

ITEM	SPECIFICATION
Display Area (mm)	304.1(H) × 228.1 (V) (15.0-inch diagonal)
Number of Pixels	1024 (H) × 768 (V)
Pixel Pitch (mm)	0.297(H) × 0.297 (V)
Color Pixel Arrangement	RGB Vertical Stripe
Display Mode	Normally White TN
Number of colors	16.7M (8 bits/color)
Luminance	250(cd/m ²) (Typ.)
Viewing Angle	-60 ~ 60 (H), -55 ~ 45 (V) (Typ.)
Wide Viewing Angle Technology	Optical Compensation Film
Surface Treatment	Anti-glare and Hard-coating 3H
Electrical Interface	CMOS(VIN=3~5V, 2pixel/clock)
Optimum Viewing Angle	6 o'clock
Module Size (mm)	350.0 (W) × 266.5 (H) × 14.5 (D)
Module Mass (g)	1300
Backlight Unit	2 replaceable CCFLs edge-light (top/bottom)

1.3. Product Disclaimer

The LCD products listed in this document are not suitable for safety related applications that do not have redundant back-up system(s). In other words, these LCD products are not designed for use as a single source safety related application, and therefore, are not recommended for applications in which human life and/or environment may be affected in the event of the failure of the LCD product. More specifically, if there is no back-up system or product in place that will continue operating the system, the LCD products should not be used in such things as:

- (i) aircraft navigation or aerospace equipment;
- (ii) nuclear reactor control systems;
- (iii) any application where failure or inaccuracy might cause death or personal injury (e.g., life support systems); or
- (iv) military and submarine critical systems.

The LCD products are designed for typical industrial applications such as, but not are limited to the following: computers, office equipment, industrial controllers, audio and visual equipment, test and measurement devices, communication equipment, point of sale, medical imaging and automotive and various other consumer products. If there are any questions regarding the use, ability or application of these LCD products, please contact an authorized sales representative.

SIZE	MITSUBISHI ELECTRIC SPECIFICATION	REV.			
A	AA150XA01B	A	SHEET	3	OF 22

2. ABSOLUTE MAXIMUM RATINGS

2.1. Summary Table:

ITEM	SYMBOL	MIN	MAX	UNIT
Power Supply Voltage for LCD	V_{CC}		7.0	V
Logic Input Voltage	V_I	-0.5	6.1	V
Operation Temperature *2.2)	T_{op}	0	50	°C
Storage Temperature *2.2)	T_{stg}	-20	60	°C

2.2. Note:

$T_{op}, T_{stg} \leq 40^{\circ}\text{C}$: 90%RH max. without condensation

$T_{op}, T_{stg} > 40^{\circ}\text{C}$: Absolute humidity shall be less than the value of 90%RH at 40°C without condensation.

3. ELECTRICAL CHARACTERISTICS

3.1. Conditions: TFT-LCD module ambient temperature is 25°C

3.2. Summary table:

ITEM	SYMBOL	MIN	Typ.	MAX	UNIT	Remarks	
Power Supply Voltage for LCD	V_{CC}	4.5	5.0	5.5	V	Section 3.4.	
Power Supply Current LCD	I_{CC}	—	400	(680)	mA	Section 3.4.	
Permissible Input Ripple Voltage	V_{RP}	—	—	100	m Vp-p	$V_{CC}=5.0\text{V}$	
Logic Input Voltage	High	V_{IH}	2.2	3.3	5.5	V	
	Low	V_{IL}	0	—	0.8	V	

3.3. Backlight

3.3.1. The table below shows data for one lamp only.

3.3.2. The TFT-LCD module has two identical lamps operated independently.

3.3.3. Operation of both lamps is required in order to meet all the parameters in the AA150XA01B specification.

ITEM	SYMBOL	MIN	TYP	MAX	UNIT	Remarks
Lamp Voltage	V_L	—	625	—	V	$I_L=7.0\text{mA}$
Lamp Current	I_L	5.0	7.0	8.0	mA	Section 3.4.
Inverter Frequency	FI	30	—	50	kHz	
Starting Lamp Voltage	V_s	1700 1500	—	—	V V	$T_a=0^{\circ}\text{C}$ $T_a=25^{\circ}\text{C}$
Lamp Life Time	L_T	25000	—	—	hr	$I_L=7.0\text{mA}$ Continuous Operation Section 3.4.

SIZE	MITSUBISHI ELECTRIC SPECIFICATION	REV.		
A	AA150XA01B	A	SHEET	4 OF 22

3.4. Notes

3.4.1. Power and Signals sequence :

$t1 \leq 10\text{ms}$ $0 < t4 \leq 50\text{ms}$ $0 < t7$
 $0 < t2 \leq 10\text{ms}$ $1\text{sec} \leq t5$
 $0 < t3 \leq 1\text{sec}$ $200\text{ms} \leq t6$

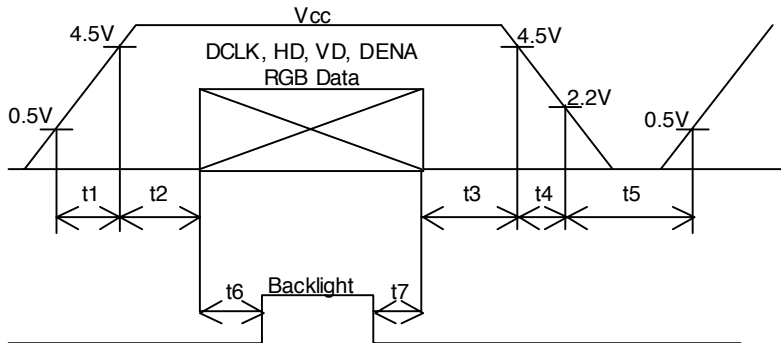

3.4.2. V_{CC} -dip conditions :

- 1) When $V_{CCMIN} \geq 3.6\text{V}$
 $t_d \leq 10\text{ms}$
- 2) $V_{CCMIN} < 3.6\text{V}$
 V_{CC} -dip conditions should also follow the power and signals.

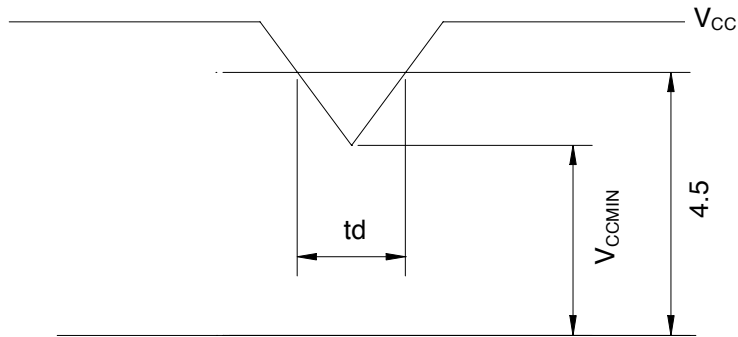

3.4.3. Test condition for I_{CC} Typical:

256 gray-bar pattern
 768 line mode
 $V_{CC} = +5\text{V}$, Input signals are typical value in section 5

3.4.4. Lamp current measurement method (The current meter is inserted in low voltage line)

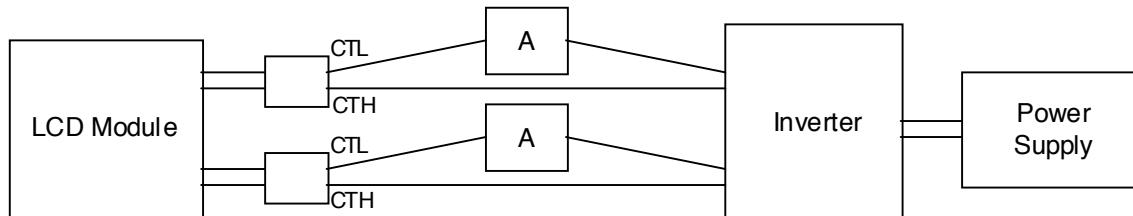

SIZE	MITSUBISHI ELECTRIC SPECIFICATION	REV.			
A	AA150XA01B	A	SHEET	5	OF 22

- 3.4.5. The operating frequency of the backlight inverter may produce interference with horizontal synchronous frequency. This may cause a horizontal 'beat' to be visible on the display. To avoid this phenomenon, please adjust backlight inverter frequency and keep the inverter as far from module (physically) as possible. Use of shielding between the backlight inverter and the display module is also effective to reduce interference.
- 3.4.6. Lamp life time is defined as the time either when the luminance becomes 50% of the initial value under the standard condition, or when the starting lamp voltage does not meet the value specified in this table.
- 3.4.7. The life time of the backlight depends on the ambient temperature. The life time will decrease under low/high temperature.

SIZE	MITSUBISHI ELECTRIC SPECIFICATION	REV.		
A	AA150XA01B	A	SHEET	6 OF 22

4. INTERFACE CONNECTORS PIN ASSIGNMENT

4.1 Input connector type (See paragraph 6.)

4.2 Input connector pin assignment table:

4.2.1 Input connector CN1: IL-FHR-45S-HF (JAE)

PIN NO.	SYMBOL	FUNCTION
1	GND	
2	DCLK	Pixel clock
3	GND	
4	DENA	Data enable
5	GND	
6	VD	Vertical sync
7	GND	
8	HD	Horizontal sync
9	GND	
10	GND	
11	GND	
12	BO7	Blue odd data (MSB)
13	BO6	Blue odd data
14	BO5	Blue odd data
15	BO4	Blue odd data
16	GND	
17	BO3	Blue odd data
18	BO2	Blue odd data
19	BO1	Blue odd data
20	BO0	Blue data signal (LSB)
21	GND	
22	GO7	Green odd data (MSB)
23	GO6	Green odd data
24	GO5	Green odd data
25	GO4	Green odd data
26	GND	
27	GO3	Green odd data
28	GO2	Green odd data
29	GO1	Green odd data
30	GO0	Green odd data (LSB)
31	GND	
32	RO7	Red odd data (MSB)
33	RO6	Red odd data
34	RO5	Red odd data
35	RO4	Red odd data
36	GND	
37	RO3	Red odd data
38	RO2	Red odd data
39	RO1	Red odd data
40	RO0	Red odd data (LSB)
41	V _{CC}	
42	V _{CC}	
43	TEST	This pin should be open. Test signal output for only internal test use.
44	TEST	This pin should be open. Test signal output for only internal test use.
45	TEST	This pin should be open. Test signal output for only internal test use.

*Note: The metal frame of the TFT-LCD module is connected to ground.

SIZE	MITSUBISHI ELECTRIC SPECIFICATION	REV.		
A	AA150XA01B	A	SHEET	7 OF 22

4.2.2 Input connector CN2: IL-FHR-30S-HF (JAE)

PIN NO.	SYMBOL	FUNCTION
1	GND	
2	BE7	Blue even data (MSB)
3	BE6	Blue even data
4	BE5	Blue even data
5	BE4	Blue even data
6	GND	
7	BE3	Blue even data
8	BE2	Blue even data
9	BE1	Blue even data
10	BE0	Blue even data (LSB)
11	GND	
12	GE7	Green even data (MSB)
13	GE6	Green even data
14	GE5	Green even data
15	GE4	Green even data
16	GND	
17	GE3	Green even data
18	GE2	Green even data
19	GE1	Green even data
20	GE0	Green even data (LSB)
21	GND	
22	RE7	Red even data (MSB)
23	RE6	Red even data
24	RE5	Red even data
25	RE4	Red even data
26	GND	
27	RE3	Red even data
28	RE2	Red even data
29	RE1	Red even data
30	RE0	Red even data (LSB)

4.2.3 CN3, 4

Backlight-side connector: BHR-03VS-1 (JST)
 Inverter-side connector: SM02(8.0)B-BHS-1 (JST)

PIN NO.	SYMBOL	FUNCTION
1	C _{TH}	V _{BLH} (High voltage)
3	C _{TL}	V _{BLL} (Low voltage)

*Note: The metal frame of the TFT-LCD module is connected to ground.

SIZE	MITSUBISHI ELECTRIC SPECIFICATION	REV.		
A	AA150XA01B	A	SHEET	8 OF 22

5. INTERFACE TIMING

5.1. Timing Chart

5.1.1 Pixel Timing Chart

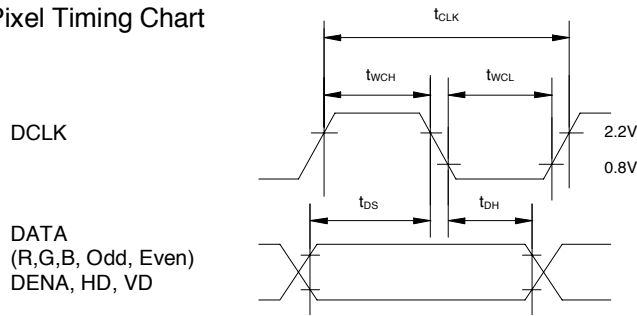

5.1.2 Horizontal Timing Chart

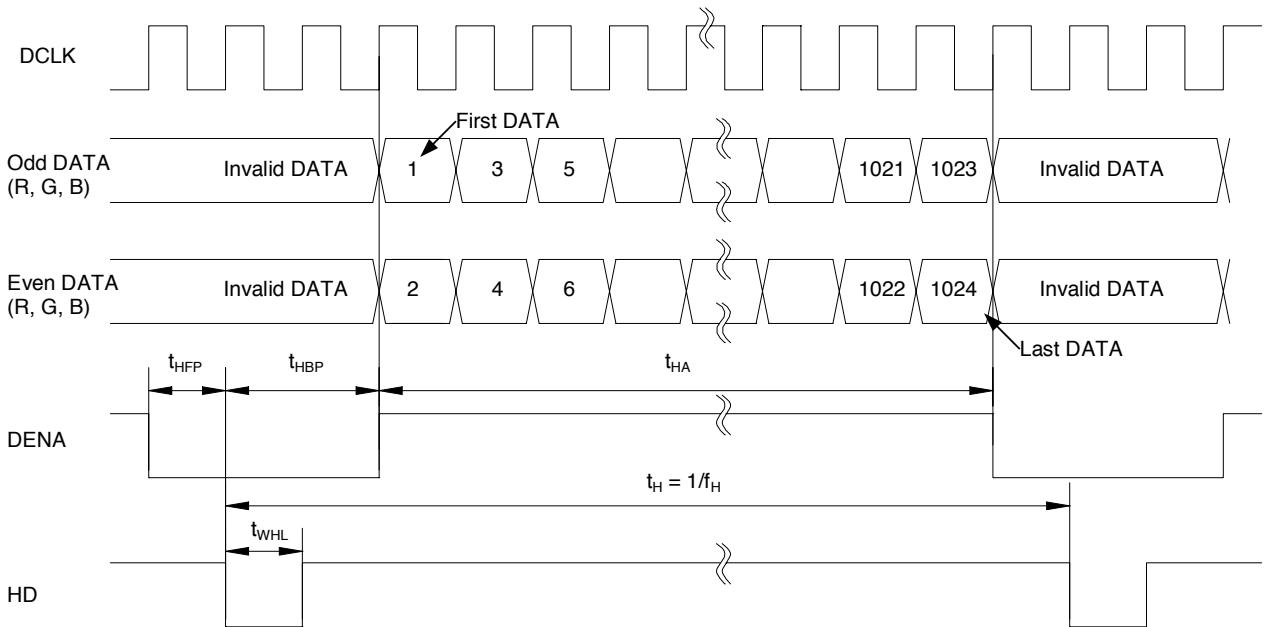

5.1.3 Vertical Timing Chart

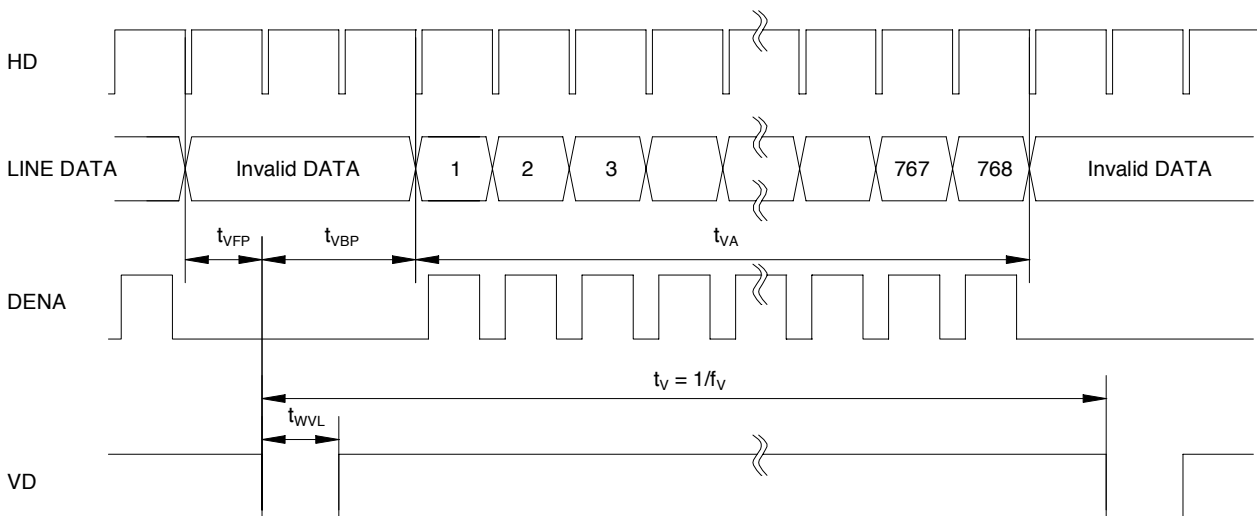

SIZE	MITSUBISHI ELECTRIC SPECIFICATION	REV.		
A	AA150XA01B	A	SHEET	9 OF 22

5.2. Timing Specification

ITEM		SYMBOL	MIN	TYP	MAX	UNIT
DCLK *	Frequency	f_{CLK}	30	32.5	40	MHz
	Period	t_{CLK}	25.0	30.8	33.3	ns
	Low Width	t_{WCL}	8	—	—	ns
	High Width	t_{WCH}	8	—	—	ns
DATA (R, G, B, DENA HD, VD)	Set up Time	t_{DS}	2.3	—	—	ns
	Hold Time	t_{DH}	7.3	—	—	ns
DENA	Horizontal Active Time	t_{HA}	512	512	512	t_{CLK}
	Horizontal Front Porch	t_{HFP}	0	12	—	t_{CLK}
	Horizontal Back Porch	t_{HBP}	6	148	—	t_{CLK}
	Vertical Active Time	t_{VA}	768	768	768	t_H
	Vertical Front Porch	t_{VFP}	0	3	—	t_H
	Vertical Back Porch	t_{VBP}	4	35	—	t_H
HD	Frequency	f_H	—	48.4	62.5	kHz
	Period	t_H	16	20.7	—	μs
	Low Width	t_{WHL}	1	68	—	t_{CLK}
VD	Frequency	f_V	55	60	75	Hz
	Period	t_V	13.3	16.7	18.2	ms
	Low Width	t_{WVL}	1	6	—	t_H

*Note 1: DCLK and HD should be applied continuously at the input connector of the TFT-LCD module during operation, subject to Section 3.4.1.

5.3. Color Data Assignment

COLOR	INPUT DATA	R DATA								G DATA								B DATA							
		R7	R6	R5	R4	R3	R2	R1	R0	G7	G6	G5	G4	G3	G2	G1	G0	B7	B6	B5	B4	B3	B2	B1	B0
		MSB							LSB	MSB							LSB	MSB							LSB
BASIC COLOR	BLACK	0	0	0	0	0	0	0	0	0	0	0	0	0	0	0	0	0	0	0	0	0	0	0	0
	RED(255)	1	1	1	1	1	1	1	1	0	0	0	0	0	0	0	0	0	0	0	0	0	0	0	0
	GREEN(255)	0	0	0	0	0	0	0	0	1	1	1	1	1	1	1	1	0	0	0	0	0	0	0	0
	BLUE(255)	0	0	0	0	0	0	0	0	0	0	0	0	0	0	0	0	1	1	1	1	1	1	1	1
	CYAN	0	0	0	0	0	0	0	0	1	1	1	1	1	1	1	1	1	1	1	1	1	1	1	1
	MAGENTA	1	1	1	1	1	1	1	1	0	0	0	0	0	0	0	0	1	1	1	1	1	1	1	1
	YELLOW	1	1	1	1	1	1	1	1	1	1	1	1	1	1	1	1	0	0	0	0	0	0	0	0
WHITE	1	1	1	1	1	1	1	1	1	1	1	1	1	1	1	1	1	1	1	1	1	1	1	1	
RED	RED(0)	0	0	0	0	0	0	0	0	0	0	0	0	0	0	0	0	0	0	0	0	0	0	0	0
	RED(1)	0	0	0	0	0	0	0	1	0	0	0	0	0	0	0	0	0	0	0	0	0	0	0	0
	RED(2)	0	0	0	0	0	0	1	0	0	0	0	0	0	0	0	0	0	0	0	0	0	0	0	0
	:																								
	:																								
	RED(254)	1	1	1	1	1	1	1	0	0	0	0	0	0	0	0	0	0	0	0	0	0	0	0	0
	RED(255)	1	1	1	1	1	1	1	1	0	0	0	0	0	0	0	0	0	0	0	0	0	0	0	0
GREEN	GREEN(0)	0	0	0	0	0	0	0	0	0	0	0	0	0	0	0	0	0	0	0	0	0	0	0	0
	GREEN(1)	0	0	0	0	0	0	0	0	0	0	0	0	0	0	0	1	0	0	0	0	0	0	0	0
	GREEN(2)	0	0	0	0	0	0	0	0	0	0	0	0	0	0	1	0	0	0	0	0	0	0	0	0
	:																								
	:																								
	GREEN(254)	0	0	0	0	0	0	0	0	1	1	1	1	1	1	1	0	0	0	0	0	0	0	0	0
	GREEN(255)	0	0	0	0	0	0	0	0	1	1	1	1	1	1	1	1	0	0	0	0	0	0	0	0
BLUE	BLUE(0)	0	0	0	0	0	0	0	0	0	0	0	0	0	0	0	0	0	0	0	0	0	0	0	0
	BLUE(1)	0	0	0	0	0	0	0	0	0	0	0	0	0	0	0	0	0	0	0	0	0	0	0	1
	BLUE(2)	0	0	0	0	0	0	0	0	0	0	0	0	0	0	0	0	0	0	0	0	0	0	1	0
	:																								
	:																								
	BLUE(254)	0	0	0	0	0	0	0	0	0	0	0	0	0	0	0	0	1	1	1	1	1	1	1	0
	BLUE(255)	0	0	0	0	0	0	0	0	0	0	0	0	0	0	0	0	1	1	1	1	1	1	1	1

5.3.1. Definitions
 Gray scale: Color (n) → n indicates gray scale level.
 Data: 1=High, 0=Low
 This assignment is applied to both odd and even data.

5.3.2. Data Mapping

D(1,1)	D(2,1)	—	D(X,1)	—	D(1023, 1)	D(1024, 1)
D(1,2)	D(2,2)	—	D(X,2)	—	D(1023, 2)	D(1024, 2)
		+		+		
D(1,Y)	D(2,Y)	—	D(X,Y)	—	D(1023,Y)	D(1024, Y)
		+		+		
D(1,767)	D(2,767)	—	D(X,767)	—	D(1023,767)	D(1024, 767)
D(1,768)	D(2,768)	—	D(X,768)	—	D(1023, 768)	D(1024, 768)

6. BLOCK DIAGRAM

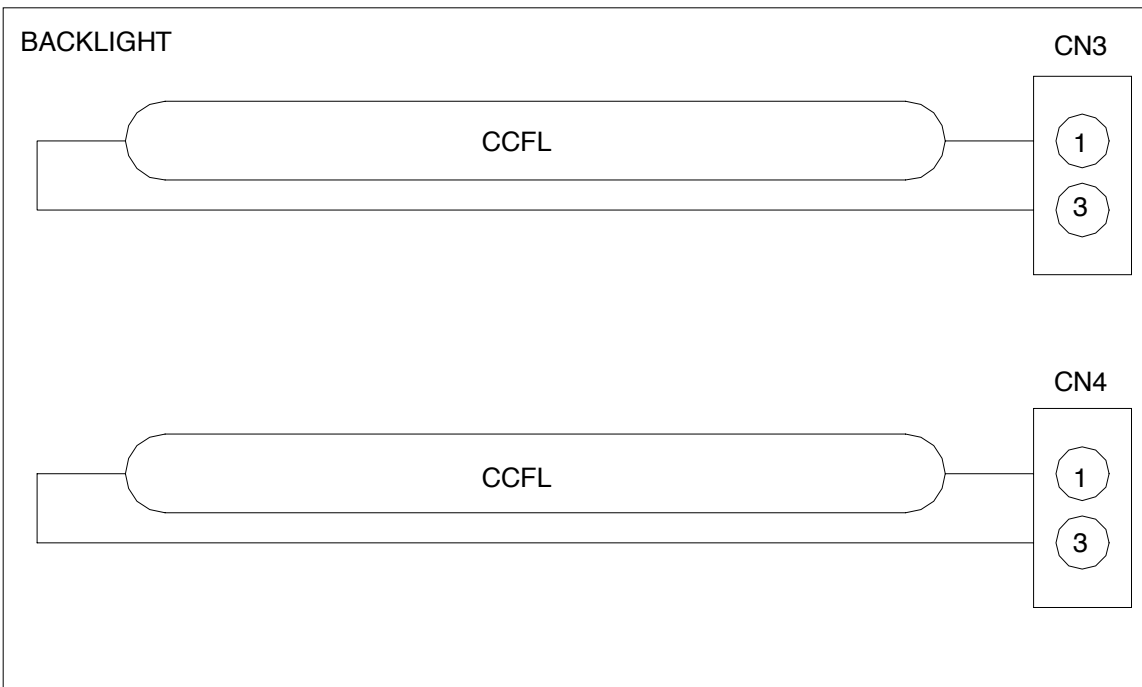
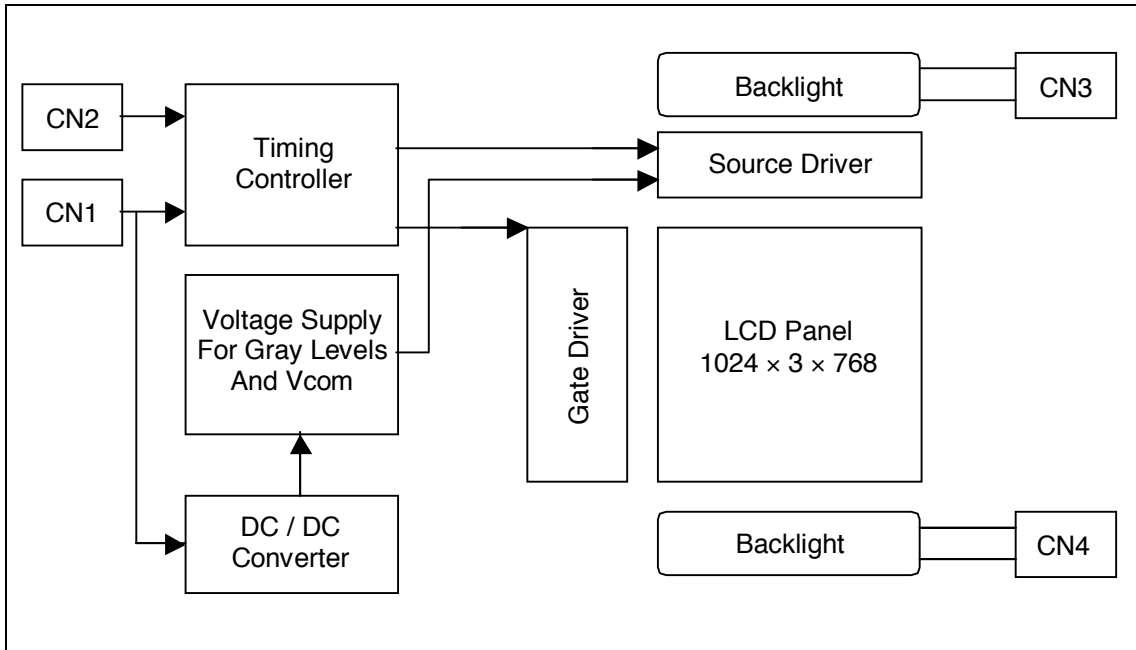

SIZE	MITSUBISHI ELECTRIC SPECIFICATION	REV.			
A	AA150XA01B	A	SHEET	13	OF 22

7. MECHANICAL SPECIFICATION
7.1. Front Side Drawing

AA150XA01B

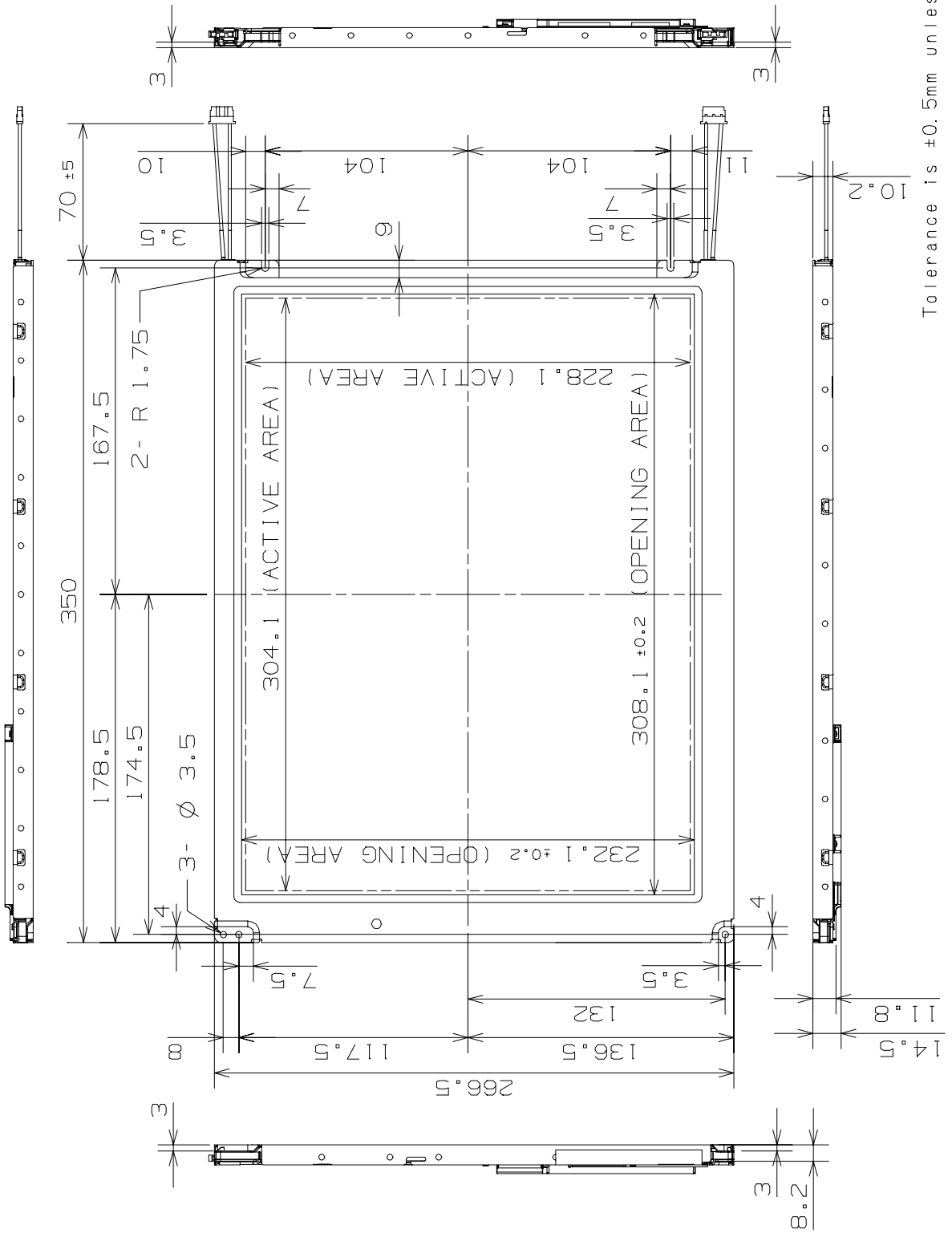

Tolerance is ±0.5mm unless noted.

SIZE	MITSUBISHI ELECTRIC SPECIFICATION	REV.			
A	AA150XA01B	A	SHEET	14	OF 22

7.2. Rear Side Drawing

AA150XA01B

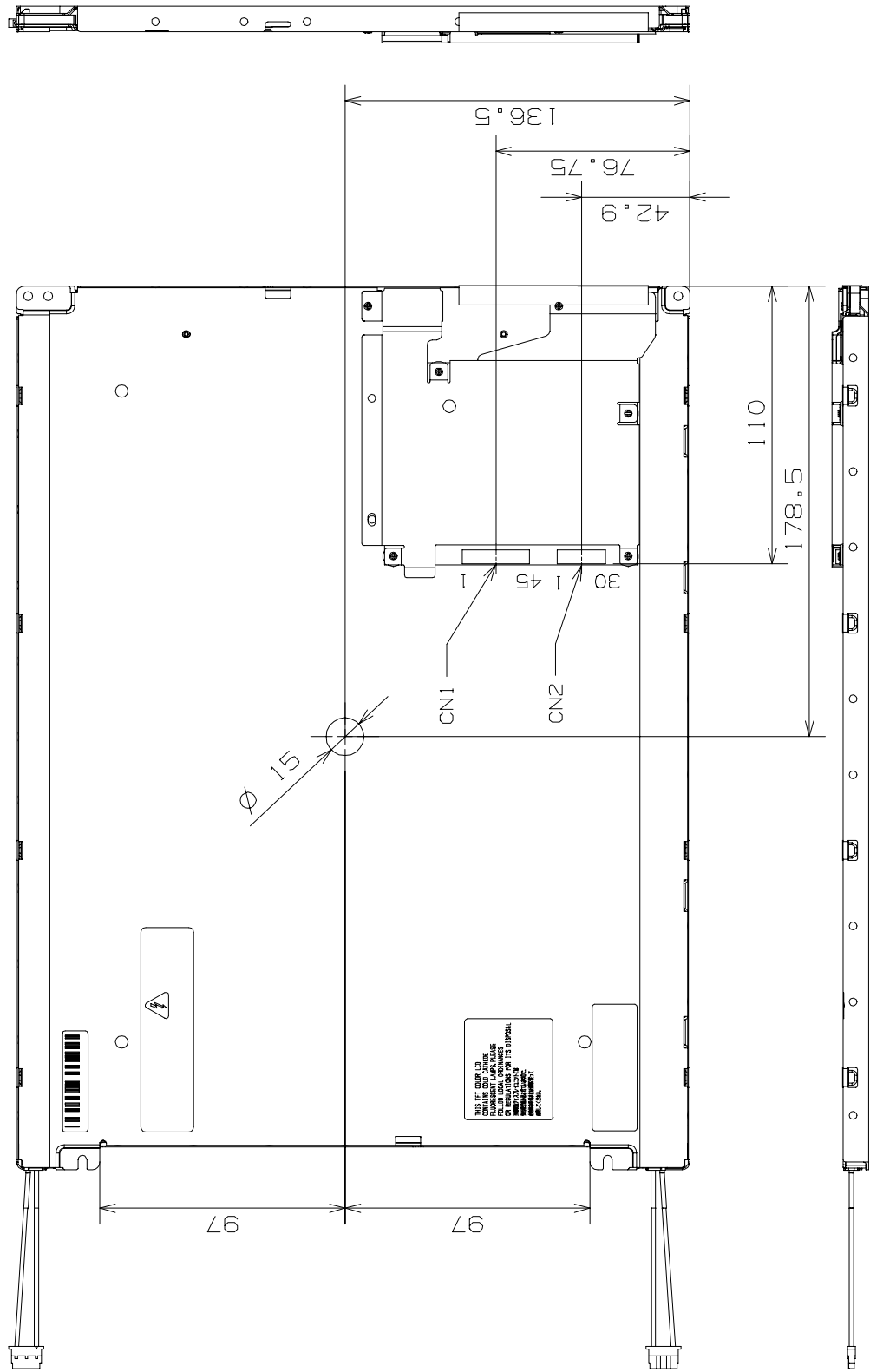

Tolerance is ±0.5mm unless noted.

SIZE	MITSUBISHI ELECTRIC SPECIFICATION	REV.			
A	AA150XA01B	A	SHEET	15	OF 22

8. OPTICAL CHARACTERISTICS

8.1. Summary table:

ITEM		SYMBOL	CONDITION	MIN	TYP	MAX	UNIT
Contrast Ratio		CR	$\theta = \phi = 0^\circ$	(200)	350	—	
Luminance	Normal	L_w	$\theta = \phi = 0^\circ$	200	250	—	cd/m ²
	Uniformity	ΔL_w	$\theta = \phi = 0^\circ$	—	—	30	%
Response Time		t_r	$\theta = \phi = 0^\circ$	—	10	—	ms
		t_f	$\theta = \phi = 0^\circ$	—	25	—	ms
Viewing Angle	Horizontal	ϕ	CR \geq 10	—	-60~60	—	°
	Vertical	θ		—	-55~45	—	°
Image Sticking		t_{is}	2 hours	—	—	2	s
Color Coordinates	Red	R _x R _y	$\theta = \phi = 0^\circ$	0.572 0.317	0.602 0.347	0.632 0.377	—
	Green	G _x G _y		0.293 0.543	0.323 0.573	0.353 0.603	
	Blue	B _x B _y		0.125 0.118	0.155 0.148	0.185 0.178	
	White	B _x B _y		0.294 0.319	0.324 0.349	0.354 0.379	

These items are measured using BM-5A (TOPCON) or LCD-7000 (Otsuka Electronic) under the dark room condition (no ambient light) after more than 30 minutes from turning on the lamp unless noted.

*) Condition: $I_L=7.0mA$, Inverter frequency: 40kHz

Ambient Temperature 25°C, $V_{CC}=5V$, signal timings are typical values in section 5.

Definitions of these measurement items are as follows:

1) Definition of Contrast Ratio

$$CR = \text{ON (White) Luminance} / \text{OFF (Black) Luminance}$$

2) Definition of Luminance and Luminance Uniformity

$$\Delta L_w = [L_w(\text{MAX}) / L_w(\text{MIN}) - 1] \times 100$$

Measure White Luminance on the 5 points below:

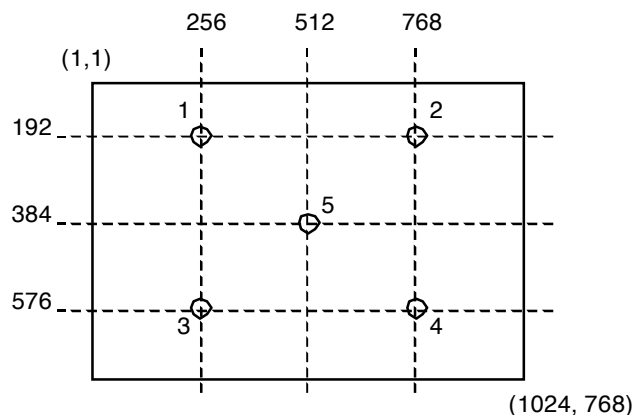

SIZE	MITSUBISHI ELECTRIC SPECIFICATION	REV.			
A	AA150XA01B	A	SHEET	16	OF 22

- 8.2. Definitions
- 8.2.1. Contrast Ratio CR = ON (White) Luminance / OFF (Black) Luminance
- 8.2.2. Viewing Angle (θ , ϕ) - See drawing below :

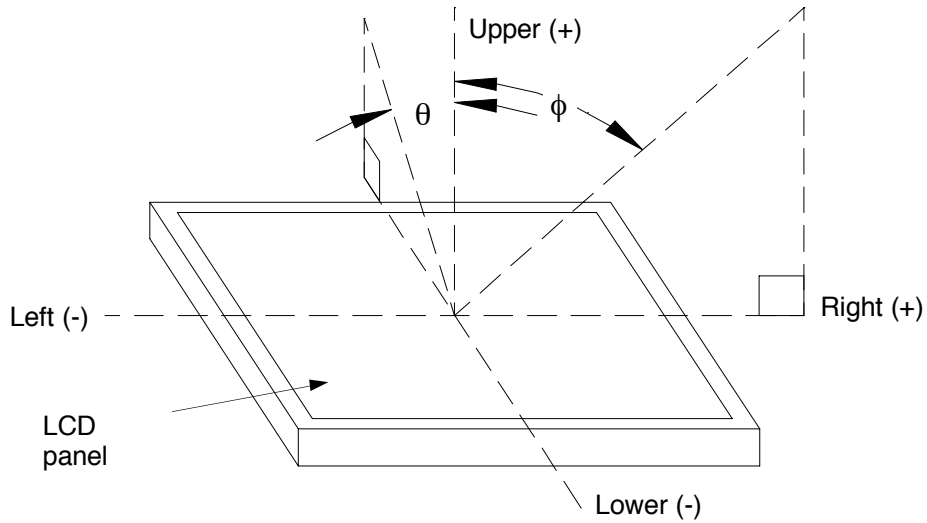

8.2.3. Definition of Response Time t_r and t_f :

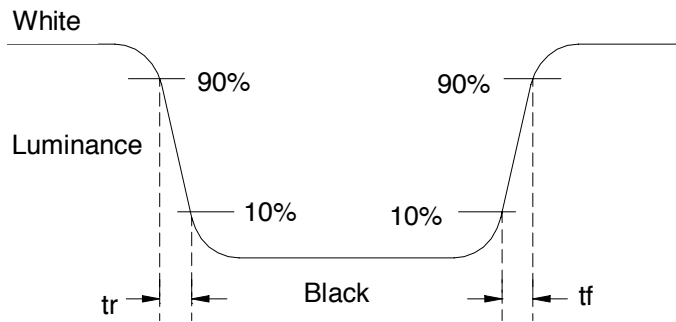

8.2.4. Test Pattern for Image Sticking Test

Continuously display the test pattern shown in the figure below for two-hours. Then display a completely white screen. The previous image shall not persist more than two seconds at 25°C.

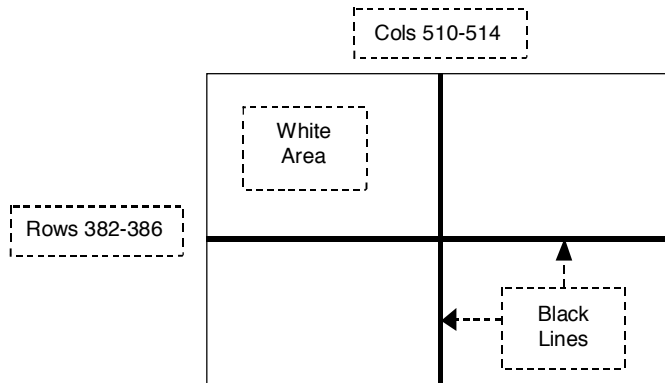

SIZE	MITSUBISHI ELECTRIC SPECIFICATION	REV.			
A	AA150XA01B	A	SHEET	17	OF 22

9. RELIABILITY TEST CONDITIONS

9.1. Temperature and Humidity

TEST ITEM	CONDITIONS
High Temperature and High Humidity Operation	40°C, 90%RH, 240 hours (No condensation)
High Temperature Operation	50°C, 240 hours
Low Temperature Operation	0°C, 240 hours
Thermal Shock	Between -20°C (1 hour) and 60°C (1 hour) 5 cycles
High Temperature Storage	60°C, 240 hours
Low Temperature Storage	-20°C, 240 hours

9.2. Shock and Vibration

TEST ITEM	CONDITIONS
Shock (non-operating)	Shock level: 980 m/s ² (100G) Waveform: half sinusoidal wave, 2 ms Number of shocks: one shock input in each direction of three mutually perpendicular axes for a total of six shock inputs
Vibration (non-operating)	Vibration level: 9.8 m/s ² (1.0G) Waveform: sinusoidal Frequency range: 5 to 500 Hz Frequency sweep rate: 0.5 octave/min Duration: one sweep from 5 to 500 to 5Hz in each of three mutually perpendicular axes (each x,y,z axis: 1 hour, total 3 hours)

- 9.3. Judgment Standard – Pass/Fail criteria for reliability tests is defined as follows:
 Pass: Normal display image with no obvious non-uniformity and no line defect.
 Fail : No display image, obvious non-uniformity, or line defect.

SIZE	MITSUBISHI ELECTRIC SPECIFICATION	REV.		
A	AA150XA01B	A	SHEET	18 OF 22

11. HANDLING PRECAUTIONS FOR TFT-LCD MODULE - Please observe the recommendations included in this paragraph when handling the TFT-LCD modules!

11.1. ASSEMBLY PRECAUTIONS

- 11.1.1. Please use the mounting hole on the module corners for installation and avoid bending or wrenching LCD during assembly process. Do not drop, bend or twist the TFT-LCD module during handling.
- 11.1.2. Guidelines for designing the TFT-LCD module enclosure:
 - 11.1.2.1. Housing case must be designed carefully so as not to put stresses on LCD all sides and not to wrench module. Mechanical stress to the TFT-LCD module may degrade the reliability and overall performances of the display (like luminance uniformity degradation...etc.).
 - 11.1.2.2. Keep sufficient clearance between LCD module back surface and housing when the LCD module is mounted. Approximately 1.0 mm of the clearance in the design is recommended taking into account the tolerance of LCD module thickness and mounting structure height on the housing.
 - 11.1.2.3. When some parts, such as FPC cable and ferrite plate, are installed underneath the LCD module, still sufficient clearance is required, such as 0.5mm. This clearance is to be reconsidered when additional parts are inserted for EMI countermeasures.
 - 11.1.2.4. Choose carefully the inverter location to avoid any stress to the lamp cable. The lamp cable also should not interfere with the module installation into the enclosure.
 - 11.1.2.5. Keep sufficient clearance between LCD module and the others components, such as inverter and speaker so as not to interfere with the LCD module. Approximately 1.0 mm of the clearance in the design is recommended.
 - 11.1.2.6. Please connect the metal frame of the module to GND in order to minimize the effect of external noise and EMI.
- 11.1.3. Do not apply pressure or scratch LCD panel surface with anything hard. Do not soil LCD panel surface by touching with bare hands. (The anti-glare surface treatment is only effective when the module surface of the display is clean and unmarred.)
- 11.1.4. Do not apply pressure on any parts on the rear side such as source TCP, gate TCP, control circuit board and FPCs during handling LCD module.
- 11.1.5. Wipe off LCD panel surface with absorbent cotton or soft cloth to clean the surface.
- 11.1.6. Wipe off immediately any liquids which may have accidentally being sprayed on LCD panel surface. Droplets on the LCD panel surface may alter the quality of the image.
- 11.1.7. Do not disassemble the TFT-LCD module for any reasons. By doing so you void the warranty of the TFT-LCD module and is very likely that the performances will be degraded considerably.
- 11.1.8. Do not touch metal frames with bare hands and soiled gloves. If fingerprints or dirt are not cleaned immediately with solvent it is very likely that permanent marks will be left on the metal surfaces.
- 11.1.9. Disconnect the lamp wires before handling the inverter. Otherwise, it is possible to damage the lamp and or the lamp wires by pulling it together with the inverter.

11.2. OPERATING PRECAUTIONS

- 11.2.1. Turn off the power supply before connecting and disconnecting signal input cable.
- 11.2.2. Do not change the setting of the adjustable resistors on TFT-LCD module subassemblies. The adjustable resistors are properly set at the factory and any deviation from the factory setting will compromise the performances of the TFT-LCD module.
- 11.2.3. When evaluating the optical characteristics of the display please note that will take longer time for the backlight to stabilize if the ambient temperature is at the lower end of the temperature range.
- 11.2.4. Sudden changes of the ambient temperature may cause condensation on various surfaces of the TFT-LCD module and degrade the overall performances until the surfaces become dry again.
- 11.2.5. Follow-up the general safety rules applying to generic electronic products.

SIZE	MITSUBISHI ELECTRIC SPECIFICATION	REV.			
A	AA150XA01B	A	SHEET	21	OF 22

11.3. PRECAUTIONS WITH ELECTRONICS

- 11.3.1. This LCD module uses CMOS integrated circuits and other components subject to be affected by electrostatic discharges. Use ESD protection equipment and follow all ESD safety procedures when handling the TFT-LCD modules.
- 11.3.2. Please remove protection film very slowly from the surface of LCD module to prevent electrostatic discharge. It is recommended to lift the protection film starting from the lower left corner of the module, and pulling diagonally toward the upper right corner.

11.4. STORAGE PRECAUTIONS

- 11.4.1. Do not leave the LCDs in the environment of high humidity and high temperature.
- 11.4.2. Do not expose the TFT-LCD modules to temperatures below -20°C .

11.5. SAFETY PRECAUTIONS

- 11.5.1. When disposing LCDs it is recommended to break them into pieces. The broken pieces should be washed with solvents such as acetone and ethanol. The residual solvent from this process should be burned.
- 11.5.2. If any liquid leaks out of a damaged glass cell and comes in contact with the hands, wash it off thoroughly with soap and water.

11.6. OTHERS

- 11.6.1. Exposing the TFT-LCD module to strong incident light may negatively affect the display characteristics because of polarizer film, color filter, and other materials degradation. Do not expose LCD module to direct sunlight or light with strong ultraviolet content.
- 11.6.2. Avoid any contact of the TFT-LCD module front surface with other objects or materials.

11.7. PACKAGING AND SHIPPING

- 11.7.1. Packaging box and inner case for LCD are designed to protect the LCDs from the damage or scratching during transportation. Do not open the packaging box unnecessarily.
- 11.7.2. Do not stack more than 5 boxes on top of each other because stack of 5 is maximum designed limit. Do not turn over the boxes.
- 11.7.3. Avoid excessive shock; the shipping boxes are not designed to be thrown. Excessive vibrations can also damage the boxes and the TFT-LCD modules inside.
- 11.7.4. Packaging box and the inner structures of it are made of cardboard. Avoid having the boxes in contact with water or in high humidity environment which may cause the carton to become soft, or to break, damaging the TFT-LCD modules inside.

SIZE	MITSUBISHI ELECTRIC SPECIFICATION	REV.				
A	AA150XA01B	A	SHEET	22	OF	22