



# NAN YA PLASTICS CORPORATION

Reference Only

## SPECIFICATION OF LCD MODULE

PRODUCT NO.: LVC95Z780VS\_

SPEC. NO.: RLM780-0-△

CUSTOMER
APPROVED BY
DATE:

LCD DEPARTMENT  
ELECTRONIC MATERIALS DIVISION  
NAN YA PLASTIC CORPORATION  
201, TUNG HWA N. ROAD, TAIPEI  
TEL:886-2-27122211 EXT.5993~5996  
FAX:886-2-27178253  
E-mail:lcdsales@npc.com.tw

EDITED ON : JULY. 18, 2007

Q.C. DEPT.	DESIGN MANAGER	DESIGN CHECK	DESIGNER



## 1. MECHANICAL SPECIFICATIONS

### 1.1 Description

The module is a transmissive type's TFT (Thin Film Transistor) active matrix color liquid crystal display (LCD) comprising an amorphous silicon TFT attached to each signal electrode. This model is consisting of TFT-LCD module with touch panel, a driver circuit and a back-light unit. The resolution of 4.3" contains 480×272 pixels and can display up to 16.7M colors.

### 1.2 Features

- Transmissive type and back-light with seven LEDs (Light Emitting Diodes)
- Support digital serial/parallel RGB interface.
- IC : Source Driver: HX8227-A, Gate Driver: HX8655-A
- Line inversion driving .
- Image Reversion: Up/Down and Left/Right
- LCM technological conditions: ROHS

### 1.3 Mechanical Data

Item	Specification	Unit
Module Size	105.5(H) x 67.2(V) X MAX 4.2(D)	mm
Viewing Area	95.04(H) X 53.856(V)	mm
Number of Pixel	480(H)*RGB X 272(V)	pixel
Pixel Pitch	0.198(H) X 0.198(V)	mm
Display mode	Normally White	-
Viewing direction	6	o'clock
Display mode	Normally White	-
Backlight	LED	-
Touch Panel	Excluded	-
Weight	71.1 (Approx.)	g

**2.ABSOLUTE MAXIMUM RATINGS**

Item	Symbol	Standard Value			Unit
		Min.	Typ.	Max.	
Supply Voltage For Logic	DVDD	-0.3	-	+6.0	V
Supply Voltage For LCD Drive	AVDD	-0.3	-	+6.0	
Input Voltage	V <sub>IN</sub>	-0.3	-	DVDD+0.3	
Operating Temp.	T <sub>OP</sub>	-20	-	+70	°C
Storage Temp.	T <sub>ST</sub>	-30	-	+70	

### 3.ELECTRICAL CHARACTERISTICS

#### 3-1.Electrival Characteristics of LCM

Item		Symbol	Test Condition	Min.	Typ.	Max.	Unit
Logic Supply Voltage		DVDD	Ta=25°C	2.25	2.5	3.6	V
LCD Drive Voltage		AVDD		4.8	5.0	5.2	V
Input Voltage	"H" Level	V <sub>IH</sub>		0.7DVDD	-	DVDD	V
	"L" Level	V <sub>IL</sub>		VSS	-	0.3DVDD	V

#### 3-2. Electrical Characteristics of Backlight

Item	Symbol	Test Condition	Min.	Typ.	Max.	Unit
Current	I <sub>AK</sub>	Ta=25°C	-	-	20	mA
Forward Voltage	V <sub>AK</sub>	I <sub>AK</sub> = 20mA Ta=25°C	-	23.1	-	V
Power Consumption	P	Ta=25°C	-	462	-	mW

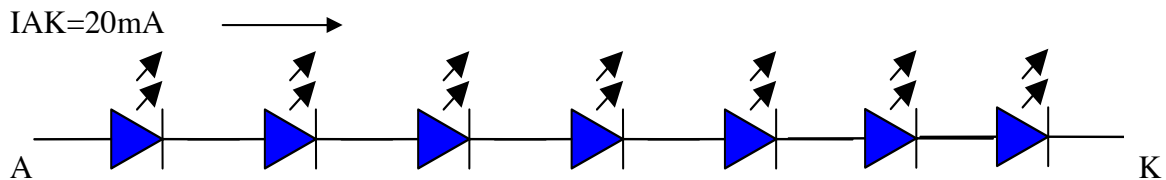

**4. ELECTRO – OPTICAL CHARACTERISTICS**

Item	Symbol	Temp.	Min.	Typ.	Max.	Unit	Conditions	Note
Viewing Angle	$\theta_L$	25°C	-	(70)	-	Deg.	CR ≥ 10 B / L on-	1
	$\theta_R$		-	(70)	-			
	$\phi_H$		-	(35)	-			
	$\phi_L$		-	(65)	-			
Contrast Ratio	Cr		200	300	-	-		3
Response Time	Tr		-	(15)	(20)	ms	$\theta = 0^\circ$ $\phi = 0^\circ$	4
	Tf		-	(35)	(50)			
Luminance	L (white)		340	360		cd / m <sup>2</sup>	B/L turn on I <sub>AK</sub> =20mA	2
Color chromaticity (CIE 1931)	White		0.28/0.30	0.31/0.33	0.34/0.36	X / Y		
	Red		0.58/0.32	0.61/0.35	0.64/0.38			
	Green		0.31/0.57	0.34/0.60	0.37/0.63			
	Blue		0.12/0.06	0.15/0.09	0.18/0.12			

Note1 . Definition of Angle  $\theta$  &  $\phi$

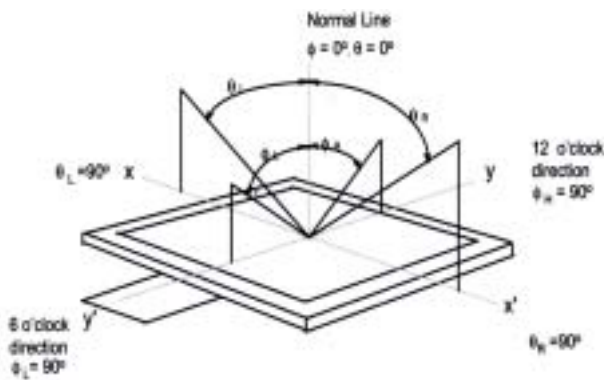

Note2. Photo detector: BM-7

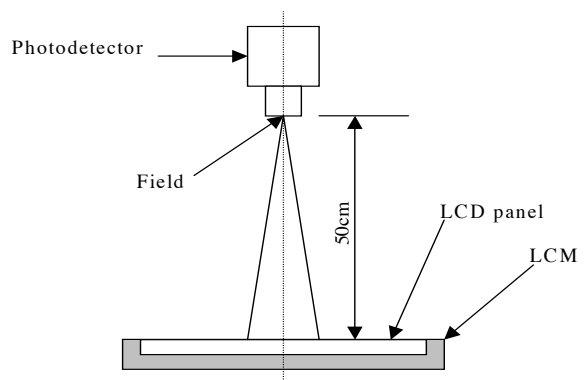

Note3 . Definition of Contrast Cr

$$Cr = \frac{\text{Luminance all pixels "White"}}{\text{Luminance all pixels "Dark"}}$$

Note4. Definition of Optical Response

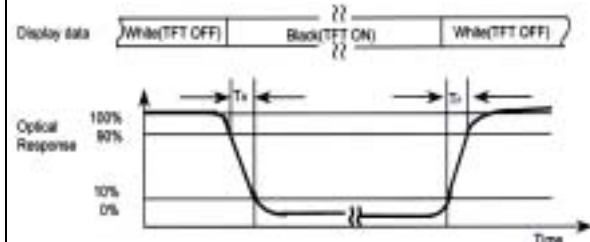

5.BLOCK DIAGRAM

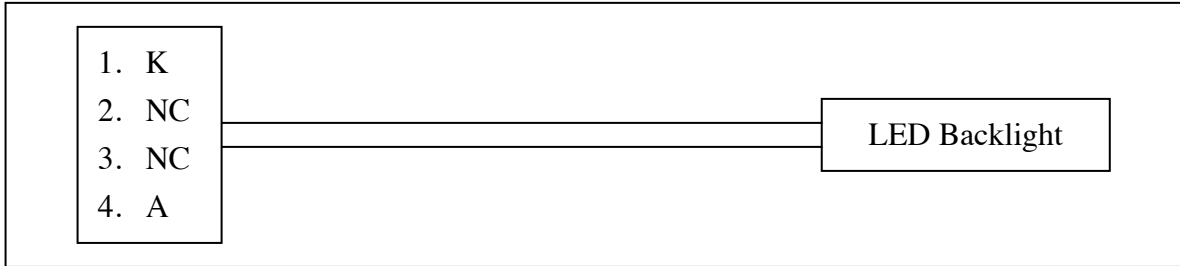
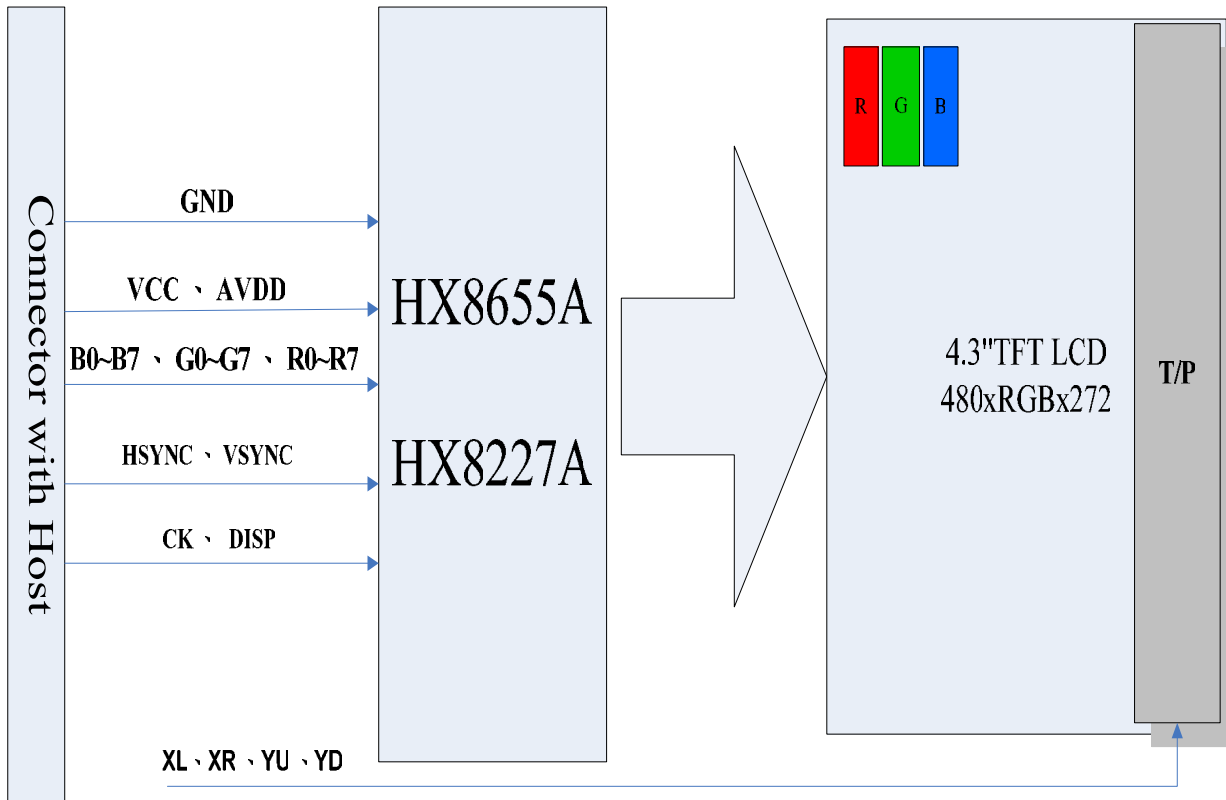

**6. LCM TERMINAL PIN FUNCTION**

Pin NO.	Symbol	I / O	Functions	Pin NO.	Symbol	I / O	Functions
1	GND	G	GND ( 0V )	21	B0	O	Blue data ( LSB )
2	GND	G	GND ( 0V )	22	B1	O	Blue data signal
3	VCC	I	+2.5V power	23	B2	O	Blue data signal
4	VCC	I	+2.5V power	24	B3	O	Blue data signal
5	R0	O	Red data ( LSB )	25	B4	O	Blue data signal
6	R1	O	Red data signal	26	B5	O	Blue data signal
7	R2	O	Red data signal	27	B6	O	Blue data signal
8	R3	O	Red data signal	28	B7	O	Blue data ( MSB )
9	R4	O	Red data signal	29	GND	G	GND ( 0V )
10	R5	O	Red data signal	30	CK	I	Clock signal to sample each date
11	R6	O	Red data signal	31	DISP	I	Display ON/OFF signal
12	R7	O	Red data ( MSB )	32	Hsync	I	Horizontal synchronizing signal
13	G0	O	Green data ( LSB )	33	Vsync	I	Vertical synchronizing signal
14	G1	O	Green data signal	34	NC	-	-
15	G2	O	Green data signal	35	AVDD	I	+5V Analog power
16	G3	O	Green data signal	36	AVDD	I	+5V Analog power
17	G4	O	Green data signal	37	PS	I	Input data format select signal. Internally pulled high. (1) PS=H Parallel RGB (2) PS=L: Serial RGB
18	G5	O	Green data signal	38	DE	I	Input data enable control
19	G6	O	Green data signal	39	GND	G	Ground
20	G7	O	Green data ( MSB )	40	GND	G	Ground

**Backlight Pin Delimiter**

<b>Pin NO</b>	1	2	3	4
<b>Symbol</b>	K	NC	NC	A



## 7.TIMING CHARACTERISTICS

### 7.1. System Interface

Please refer to HX8227-A and HX8655-A Data sheet for more details.

### 7.2 AC Timing Digrams

#### 7.2.1 Timing Requirement 1

(480RGBx272, T<sub>A</sub>=25°C, DVDD=2.25V to 3.6V, DVSS= 0V)

PARAMETER	Symbol	Min.	Typ.	Max.	Unit
Clock cycle	1/t <sub>C</sub> <sup>*1</sup>	-	9	15	MHz
Hsync cycle	1/f <sub>H</sub>	-	17.14	-	KHz
Vsync cycle	1/f <sub>V</sub>	-	59.94	-	Hz
Horizontal Signal					
Horizontal cycle	th <sup>*2</sup>	-	525	-	CLK
Horizontal display period	thd	-	480	-	CLK
Horizontal front porch	thf	2	-	-	CLK
Horizontal pulse width	thp	2	41	-	CLK
Horizontal back porch	thb	2	2	-	CLK
Vertical Signal					
Vertical cycle	tv	-	286	-	H
Vertical display period	tvd	-	272	-	H
Vertical front porch	tvf	1	2	-	H
Vertical pulse width	tvp	1	10	-	H
Vertical back porch	tvb	1	2	-	H

**Note:**

1. Parallel interface. Clock frequency and horizontal signal parameters are tripled in serial interface.  
The Maximum clock frequency of serial interface is 33MHz
2. thd=480CLK, thf=2CLK, thp=41CLK, thb=2CLK, thf + thp + thb > 44

#### 7.2.2 Timing Requirement 2

(T<sub>A</sub>=25°C, DVDD=2.25V to 3.6V, DVSS= 0V, tr=tf=2ns)

PARAMETER	Symbol	Min.	Typ.	Max.	Unit
DISP setup time	t <sub>diss</sub>	10	-	-	ns
DISP hold time	t <sub>dish</sub>	10	-	-	ns
Clock period	PW <sub>CLK</sub> <sup>*1</sup>	66.7	-	-	ns
Clock pulse high period	PWH <sup>*1</sup>	26.7	-	-	ns
Clock pulse low period	PWL <sup>*1</sup>	26.7	-	-	ns
Hsync setup time	t <sub>hs</sub>	10	-	-	ns
Hsync hold time	t <sub>hh</sub>	10	-	-	ns
Data setup time	t <sub>ds</sub>	10	-	-	ns
Data hold time	t <sub>dh</sub>	10	-	-	ns
DE setup time	t <sub>des</sub>	10	-	-	ns
DE hold time	t <sub>deh</sub>	10	-	-	ns
Vsync setup time	t <sub>vhs</sub>	10	-	-	ns
Vsync hold time	t <sub>vhh</sub>	10	-	-	ns

**Note:**

1. For parallel interface, maximum clock frequency is 15MHz.
2. tr, tf is defined 10% to 90% of signal amplitude.

7.2.3 Timing Diagram 1

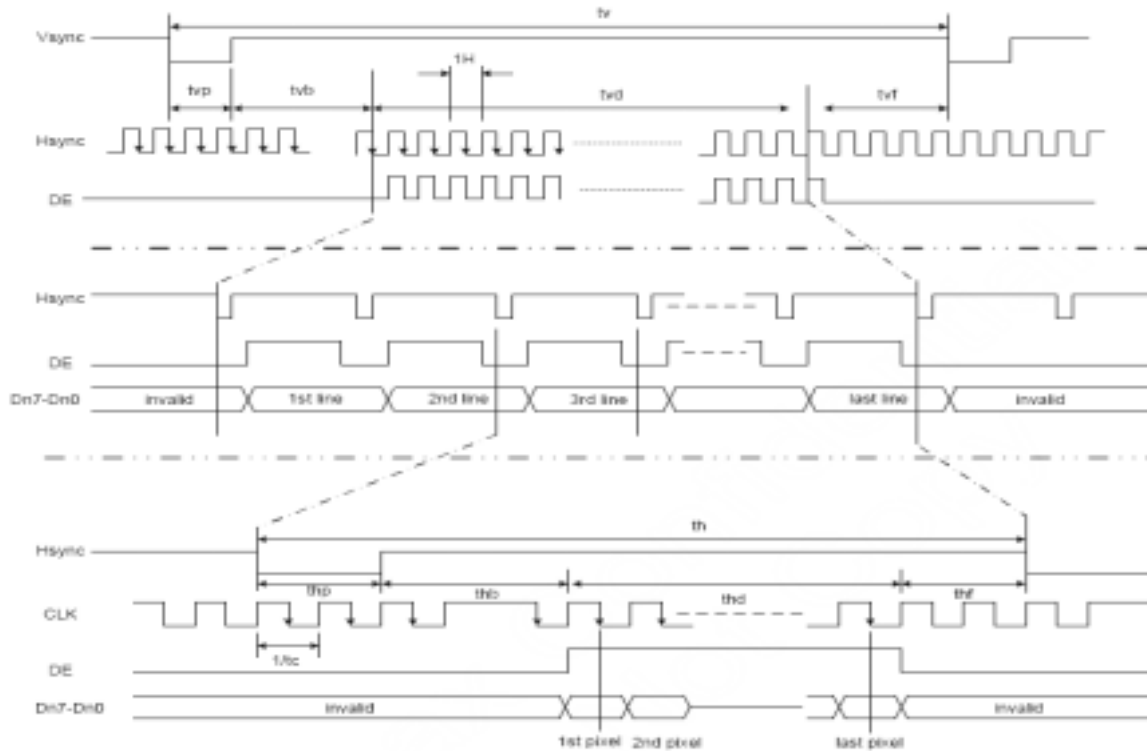

7.2.4 Timing Diagram 2

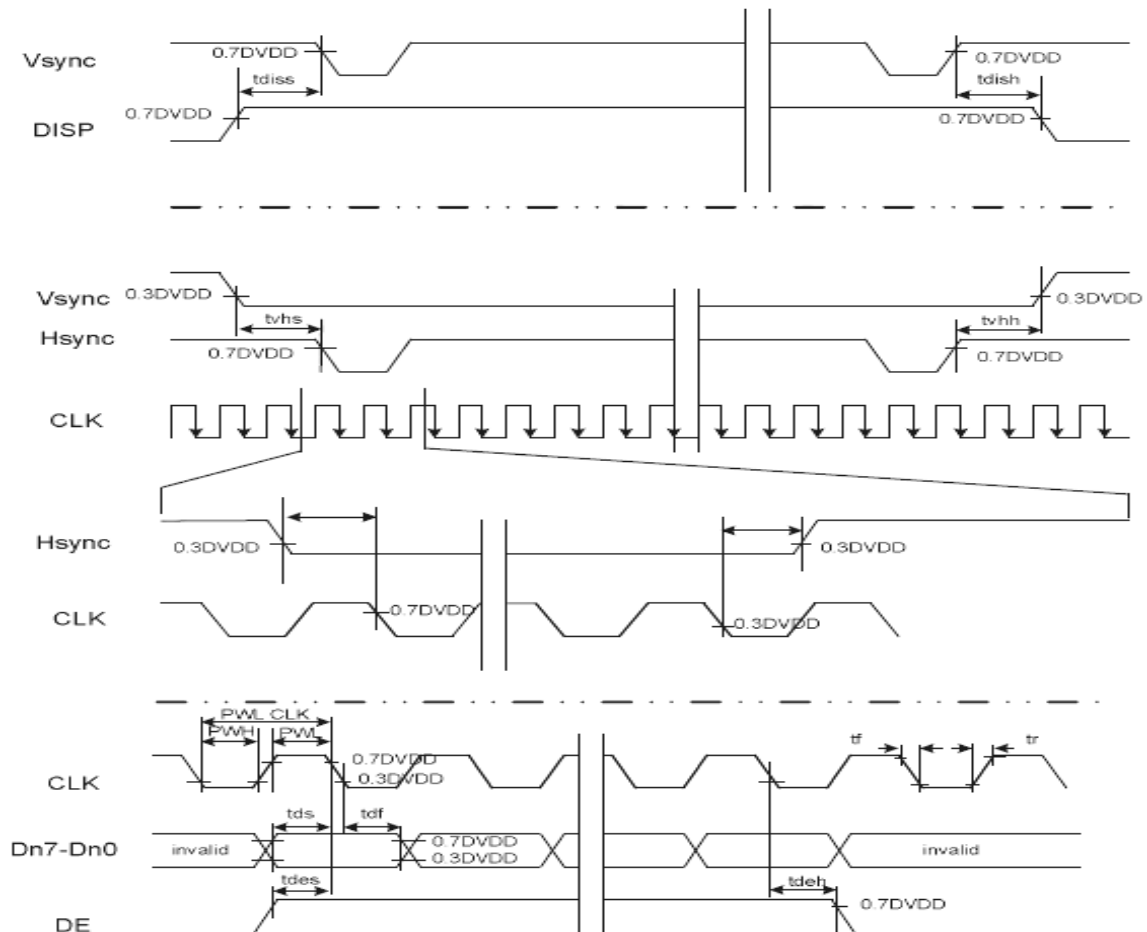

## 8. Reliability

### Contents of Reliability Tests

Item		Purpose	Conditions	Criterion
Environment Stress	High Temperature Storage	To check the product capability after long time high temperature environment stress.	Ta = 80 ± 2°C 240 hours	Brightness should be within 70% of initial value  Operational function is work
	High Temperature / Humidity Storage	To check the product capability after long time high temperature & high humidity environment stress.	Ta = 60 ± 2°C RH = 90 ± 2% 240 hours	
	Thermal Shock	To check the product capability after rapidly stress of different high/low temperature environment change.	-20°C /30 mins ⇔ 25°C /5 mins ⇔ 80°C /30 mins , 10 Cycles	

9. OUTLINE DIMENSION

