



EL320.240.36-HB
High-Bright Small Graphics Display

USER'S MANUAL

www.planar.com

Contents

EL320.240.36-HB Quarter-VGA Display	2
Features and Benefits	2
Installation and Handling.....	3
Mounting EL Displays	3
Cable Length.....	4
Cleaning	4
Avoiding Burn-In	4
Specifications	5
Control Basics	5
Power.....	5
Connector	6
<i>Dimming Connector J2</i>	7
Interface Information.....	7
<i>Video Input Signals</i>	7
Internal Frame Buffer	9
Dimming	9
Self-Test Mode.....	9
Optical.....	10
Environmental.....	10
Reliability.....	11
Safety and EMI Performance	11
Optional Features	11
Mechanical Characteristics	11
Component Envelope	11
Description of Warranty	13
Ordering Information	13
Support and Service.....	14

Figures

Figure 1. Data/Power Connector	6
Figure 2. Video Input Timing Diagram	7
Figure 3. Pixel Location versus Sequence of Data.....	8
Figure 4. Display Dimensions.....	12

Tables

Table 1. DC Input Voltage Requirements.	5
Table 2. Video Input Requirements.	5
Table 3. J1 Connector Pinouts.	6
Table 4. Video Input Descriptions.	8
Table 5. Luminance Control	9
Table 6. Optical Characteristics.	10
Table 7. Environmental Characteristics.....	10
Table 8. Mechanical Characteristics.....	11

EL320.240.36-HB Quarter-VGA Display

The EL320.240.36-HB thin film electroluminescent (EL) display is a high-performance alternative to quarter-VGA LCDs and is the ideal solution in demanding applications where superior visual performance and environmental ruggedness are critical. The EL320.240.36-HB utilizes Planar's proprietary Integral Contrast Enhancement (ICE™) technology to achieve unparalleled image quality without the use of expensive filters. This small graphics display excels in a wide range of ambient lighting environments while effectively eliminating the blooming common to other high-bright displays.

The display consists of an EL glass panel and control electronics assembled into a space-saving, rugged package for easy mounting. The EL320.240.36-HB is easily interfaced using standard 4-bit LCD control signals. Each of the 76,800 pixels is individually addressable to clearly display high information content graphics and text.

Features and Benefits

- Excellent visual performance:
 - High brightness and contrast
 - Wide viewing angle > 160°
- Rapid display response < 1 ms
- Frame Buffer
- Space efficient mechanical package
- Low EMI emissions
- Extremely rugged and durable
- Reliable, long operating life
- 4-bit LCD-type interface

Installation and Handling

Do not drop, bend, or flex the display. Do not allow objects to strike the surface of the display.

CAUTION: The display uses CMOS and power MOS-FET devices. These components are electrostatic sensitive. Unpack, assemble, and examine this assembly in a static-controlled area only. When shipping, use packing materials designed for protection of electrostatic-sensitive components.

Mounting EL Displays

Properly mounted, EL displays can withstand high shock loads as well as severe vibration found in demanding applications. However the glass panel used in an EL display will break if subjected to bending stresses, high impact, or excessive loads.

Avoid bending the display. Stresses are often introduced when a display is mounted into a product. Ideally, the mounting tabs of the display should be the only point of contact with the system. Use a spacer or boss for support; failure to do so will bend the display and cause the glass to break. The instrument enclosure or frame should not flex or distort in such a way that during use the bending loads might be transferred to the display. The EL320.240.36-HB mounting tabs were designed for a 3 mm screw. Mounting surfaces should be flat to within ± 0.6 mm (± 0.025 "). Use all the mounting holes provided. Failure to do so will impair the shock and vibration resistance of the final installation.

CAUTION: To prevent injury in the event of glass breakage, a protective overlay should be used on the viewer side of the display.

WARNING: These products generate voltages capable of causing personal injury (high voltage up to 235 V_{ac}). Do not touch the display electronics during operation.

Cable Length

A maximum cable length of 0.6 m (24 in.) is recommended. Longer cables may cause data transfer problems between the data transmitted and the display input connector. Excessive cable lengths can pick up unwanted EMI. There are third party products which allow this maximum cable length to be exceeded. Contact Planar Application Engineering for more information.

Cleaning

As with any glass or coated surface, care should be taken to minimize scratching. Clean the display glass with mild, water-based detergents only. Apply the cleaner sparingly to a soft cloth, then wipe the display. Disposable cleaning cloths are recommended to minimize the risk of inadvertently scratching the display with particles embedded in a re-used cloth. Particular care should be taken when cleaning displays with anti-glare and anti-reflective films.

Avoiding Burn-In

As with other light emitting displays, use a screen saver or image inversion to avoid causing burn-in on the display. Displaying fixed patterns on the screen can cause burn-in, where luminance variations can be noticed.

Specifications

Performance characteristics are guaranteed when measured at 25°C with rated input voltage unless otherwise specified.

Control Basics

The EL panel is a matrix structure with column and row electrodes arranged in an X-Y formation. Light is emitted when an AC voltage of sufficient amplitude is applied at a row-column intersection. The display operation is based on the symmetric, line-at-a-time data addressing scheme.

Power

The supply voltages are shown in Table 1. All internal high voltages are generated from the display supply voltage (V_H). The logic supply voltage (V_L) should be present whenever video input signals or V_H is applied. The minimum and maximum specifications in this manual should be met, without exception, to ensure the long-term reliability of the display. Planar does not recommend operation of the display outside these specifications.

Table 1. DC Input Voltage Requirements.

Parameter	Symbol	Min	Typ	Max	Absolute Max
Logic supply voltage	V_L	4.75 V	5 V	5.25 V	6 V
Logic supply current at +5 V	I_L			0.10 A	
Display supply voltage	V_H	8 V	12 V	18 V	19V
Supply current at +12 V	I_H		0.4A	0.9 A	
Power consumption @ maximum frame rate			5.5 W	11 W	
Power consumption @ 120 Hz			3.5 W		

CAUTION: Absolute maximum ratings are those values beyond which damage to the device may occur.

Table 2. Video Input Requirements.

Description	Min	Max	Units	Notes
Absolute Input Voltage Range	-0.3	5.5	V	$V_L = 5.0$ V
Video logic high voltage	2.2	5.0	V	All input thresholds are TTL
Video logic low voltage	0	0.8	V	
Video logic input current	–	±0.25	mA	±0.75 mA max Selftest
Input capacitance	–	15	pF	

There is no overcurrent protection on either the V_H or V_L inputs to protect against catastrophic faults. Planar recommends the use of a series fuse on the 12 volt supply (V_H). A general guideline is to rate the fuse at 1.8 to 2 times the display maximum current rating.

Connector

The display uses the Samtec EHT-110-01-S-D or equivalent locking connector. The mating connector is in the Samtec TCSD family of cable strips. The proper connector, user-specified cable length and connector configuration is supplied as a single unit. Consult your Samtec representative (1-800-SAMTEC9) for the cable/connector options. Compatibility with non-Samtec equivalents should be verified before use.

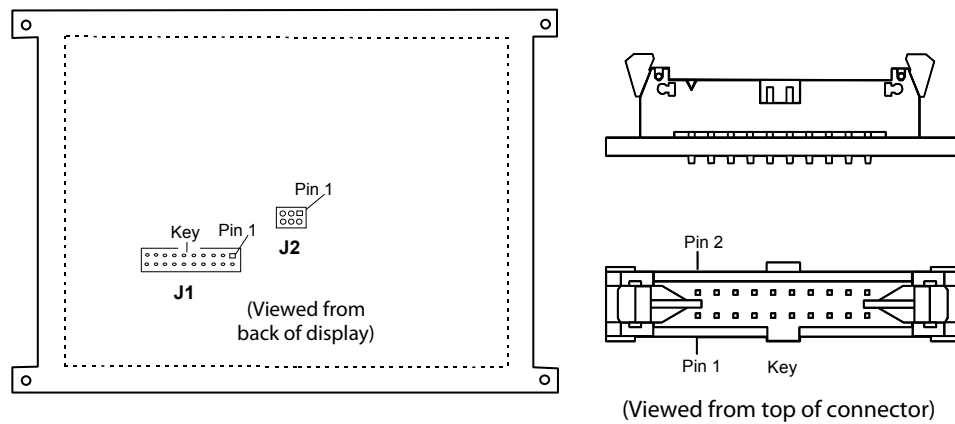

Figure 1. Data/Power Connector

Table 3. J1 Connector Pinouts.

Pin	Signal	Description	Pin	Signal	Description
1	V _H	+12 V Power	2	V _H	+12 V Power
3	Selftest	Selftest Input ¹	4	SCAN	Scan rate control
5	V _L	+5 V Power	6	GND	Ground
7	VS	Vertical Sync	8	GND	Ground
9	HS	Horizontal Sync	10	GND	Ground
11	VCLK	Video Clock	12	GND	Ground
13	VID ₀	Video Data	14	GND	Ground
15	VID ₁	Video Data	16	GND	Ground
17	VID ₂	Video Data	18	GND	Ground
19	VID ₃	Video Data	20	GND	Ground

¹ Connect pin 3 to ground for normal display operation.

Dimming Connector J2

The J2 analog dimming connector is a Berg six-pin, dual in-line header, part number 98424-G52-06LF. The mating connector is the Berg 89947-106LF (IDC) or a combination of the Berg 77138-101LF (discrete crimp-to-wire) and the Berg 903111-006LF (housing). Refer to “Dimming” on page 9 for more information.

The pin assignments are:

Pin	Symbol	Description
1	LUMA	Luminance A
2	GND	Ground
3	RESERVED	Reserved
4	LUMC	Luminance C
5	GND	Ground
6	LUMD	Luminance D

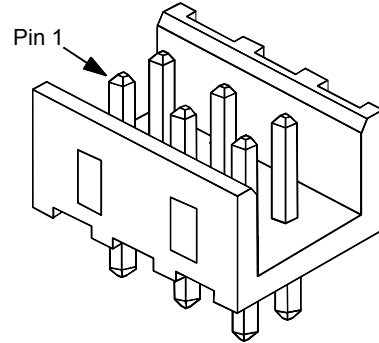

Interface Information

Planar EL Small Graphics Displays (SGD) incorporate an interface that is similar to many LCD interfaces. This interface is supported by a variety of off-the-shelf chip sets which take care of all display control functionality, freeing the system processor for other tasks. Designers should select the chip set that best suits their particular architecture and price point.

Video Input Signals

The end of the top line of a frame is marked by **VS**, vertical sync signal as shown in Figure 2. The end of each row of data is marked by **HS**. Depending on the input frame rate, a continuous low state of the **VS** input signal will shut the display scan after one frame period.

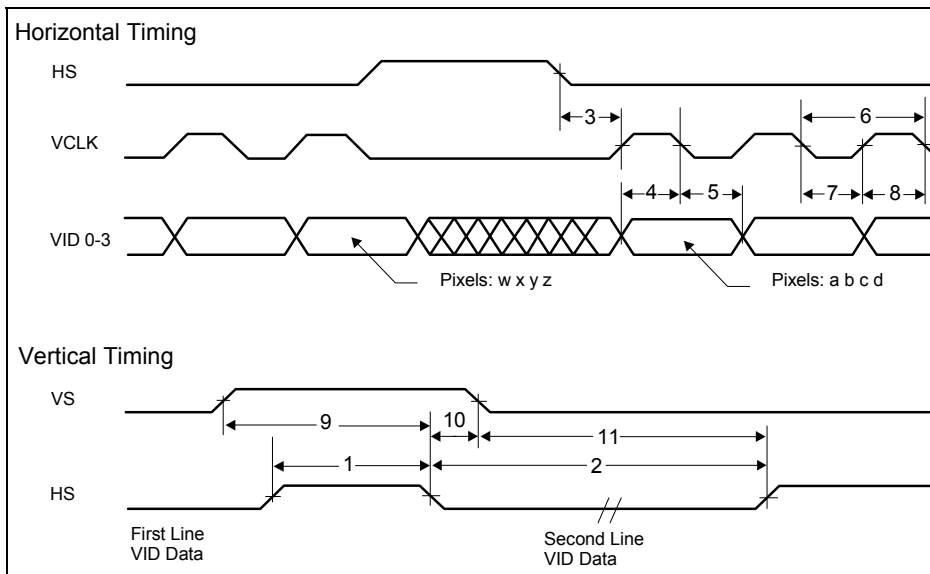

Figure 2. Video Input Timing Diagram.

Timing is compatible with LCD graphics controllers.

Table 4. Video Input Descriptions.

Num	Description	Symbol	Min.	Typ.	Max.	Units
1	HS high time	tHSh	100			nsec
2	HS low time	tHSI	80			tVCLK
3	HS to VCLK rising edge	tHSsu	95			nsec
4	VID setup to VCLK	tVIDsu	50			nsec
5	VID hold from VCLK	tVIDhd	50			nsec
6	Video clock period	tVCLK	140			nsec
	VCLK rise, fall time	tVCLKrf		10	15	nsec
7	VCLK low width	tVCLKl	30			nsec
8	VCLK high width	tVCLKh	30			nsec
9	VS high setup to HS low	tVShsu	140			nsec
10	VS hold after HS	tVShd	140			nsec
11	VS low setup to HS high	tVSlu	140			nsec
12	HS period	tHS	34			μsec
	VS period	tVS	240			tHS
	Frame Rate	fVS	1		120	Hz

Input signals **VID₀** through **VID₃** contain the video data for the screen. Pixel information is supplied from left to right and from top to bottom four pixels at a time. Video data for one row is latched on the fall of **HS**.

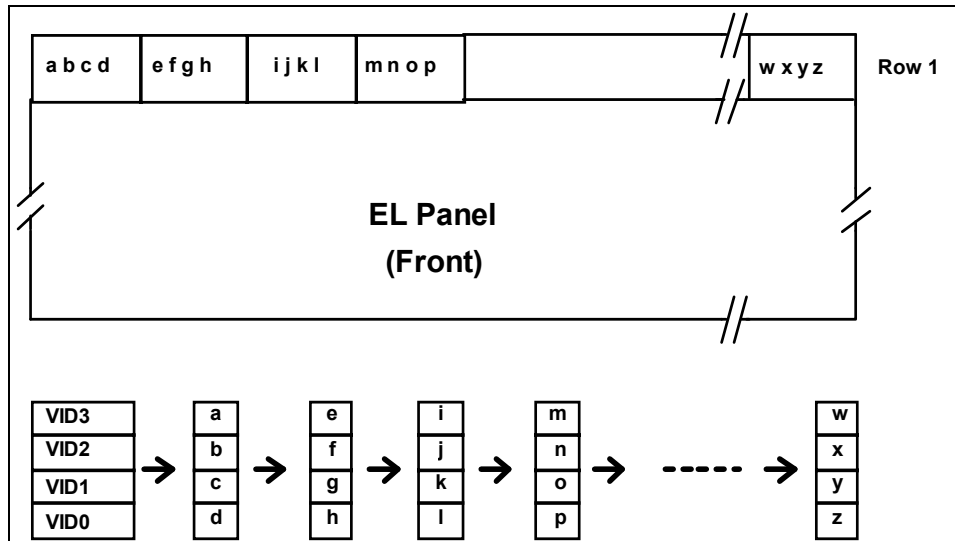

Figure 3. Pixel Location versus Sequence of Data.

Internal Frame Buffer

This display includes an internal frame buffer. The display frame rate and the display brightness are independent of user-supplied input data timing. The display frame rate can be controlled through the digital dimming feature as described below.

CAUTION: The display includes an internal frame buffer. In order to blank the display image in the event of system malfunction, pull down the VS signal.

Dimming

There are two standard methods for dimming the EL320.240.36-HB display. Analog dimming using the J2 dimming connector described on page 7 of this manual allows for manual dimming from 100% to approximately 5% of the full brightness. To perform analog dimming, connect a 50 k ohm variable resistor between LUMA and GND. Alternatively, an external voltage or current mode D/A converter may be used to facilitate dimming by sinking a maximum of 250 μ A (for maximum dimming) from LUMA to GND on the input connector. Open circuit voltage is 4 V nominal.

The internal scan frequency can be controlled via the LUMC and LUMD inputs. When LUMC and LUMD are left open, the scan rate is determined by the SCAN signal (pin 4) on the data input connector. With the combination of LUMC and LUMD, the following and luminance levels are obtained:

Table 5. Luminance Control

Approx. Relative luminance	100%	75%	50%	30%	100%	50%
LUMD (internal pull up)	High	High	Low	Low	Open	Open
LUMC (internal pull up)	High	Low	High	Low	Open	Open
SCAN (J1 pin 4)	Open	Open	Open	Open	High	Low

Self-Test Mode

The display incorporates a self-test mode composed of two patterns displayed at maximum frame rate for approximately 30 seconds each, and then repeated. The patterns are as follows: *50/50 Checkerboard* and *Full On*. The self-test mode is entered by leaving pin 3 on J1 unconnected or pulled high. This pin has an internal pull-up. Connect pin 3 on J1 to Ground for normal display operation.

Optical

Table 6. Optical Characteristics.

Luminance		
Lon (areal), min	120 cd/m ²	screen center, maximum frame rate
Lon (areal), typ	150 cd/m ²	screen center, maximum frame rate
Loff (areal), max	0.3 cd/m ²	5 points: center plus four corners measured 1.0 ±0.25" from adjacent bezel edges, @ 120 Hz
Non-uniformity		
All pixels fully lit	35%	Maximum difference two of five points, using the formula: BNU%=[1- (min_lum/max_lum)] x 100%
Luminance Variation (Temperature)		
Maximum	±25%	Across operating temperature range
Luminance Variation (Time)		
Maximum	<20%	10,000 hours at 25°C ambient
Viewing Angle		
Minimum	>160° in all directions; no contrast or luminance change	
Contrast Ratio (typical)		
	90:1	@ 500 lux ambient, maximum frame rate
	8:1	@ 10,000 lux ambient, maximum frame rate

Environmental

Table 7. Environmental Characteristics.

Temperature*	
Operating	-40°C to +85°C
Operating Survival	-40°C to +95°C
Storage	-40°C to +105°C
Humidity	
Non-condensing, operating	93% RH max at +40°C, per IEC 68-2-3
Condensing, non-operating	95% RH max at +55°C, per IEC 68-2-30
Altitude	
Operating/non-operating	0 to 18 km (58k ft) per IEC 68-2-13
Vibration	
Random	0.02 g ² /Hz, ASD level, 5-500 Hz
Operating/non-operating	per IEC 68-2-36, test Fdb.
Shock	
Operating/non-operating	100 g, 6 ms, half sine wave per IEC 68-2-27, test Ea.
* Temperature sensor is built in to provide power cut-off in case of over heating. Note: Power cut-off is not operative in Selftest.	

Reliability

The display MTBF is to be greater than 50,000 hours at 120 Hz with a 90% confidence level at 25°C.

Safety and EMI Performance

The display will not inhibit the end product from obtaining these certifications: IEC 950, IEC 601-1-1, UL2601, CSA 22.2 #601-M89, FCC Docket, Part 15, Subpart J, Class B; CISPR22, Class B; and VDE 871/VFG243 Class B.

Optional Features

Conformal coating and anti-glare filters are available as an option.

Mechanical Characteristics

Table 8. Mechanical Characteristics.

Display External Dimensions		
millimeters (inches)	width	148.1 (5.83)
	height	104.7 (4.12)
without locking connector	depth	20 (0.8)
with locking connector		
Weight (typical)		
		183 g (6.3 oz)
Fill Factor		
		74%
Display Active Area		
millimeters (inches)	width	115.1 (4.5)
	height	86.3 (3.40)
Pixel Size		
millimeters (inches)	width	0.31 (0.012)
	height	0.31 (0.012)
Pixel Pitch		
millimeters (inches)	width	0.36 (0.014)
	height	0.36 (0.014)

Component Envelope

The component envelope shown in Figure 4 illustrates the distance components extend behind the display. Tall components do not necessarily fill this area. Planar reserves the right to relocate components *within* the constraints of the component envelope without prior customer notification. For this reason, Planar advises users to design enclosure components to be outside the component envelope.

Device designers will need to consider their specific system requirements to determine the spacing necessary to maintain the specified ambient temperature.

Air flow and surrounding component materials will affect the depth of the air gap.

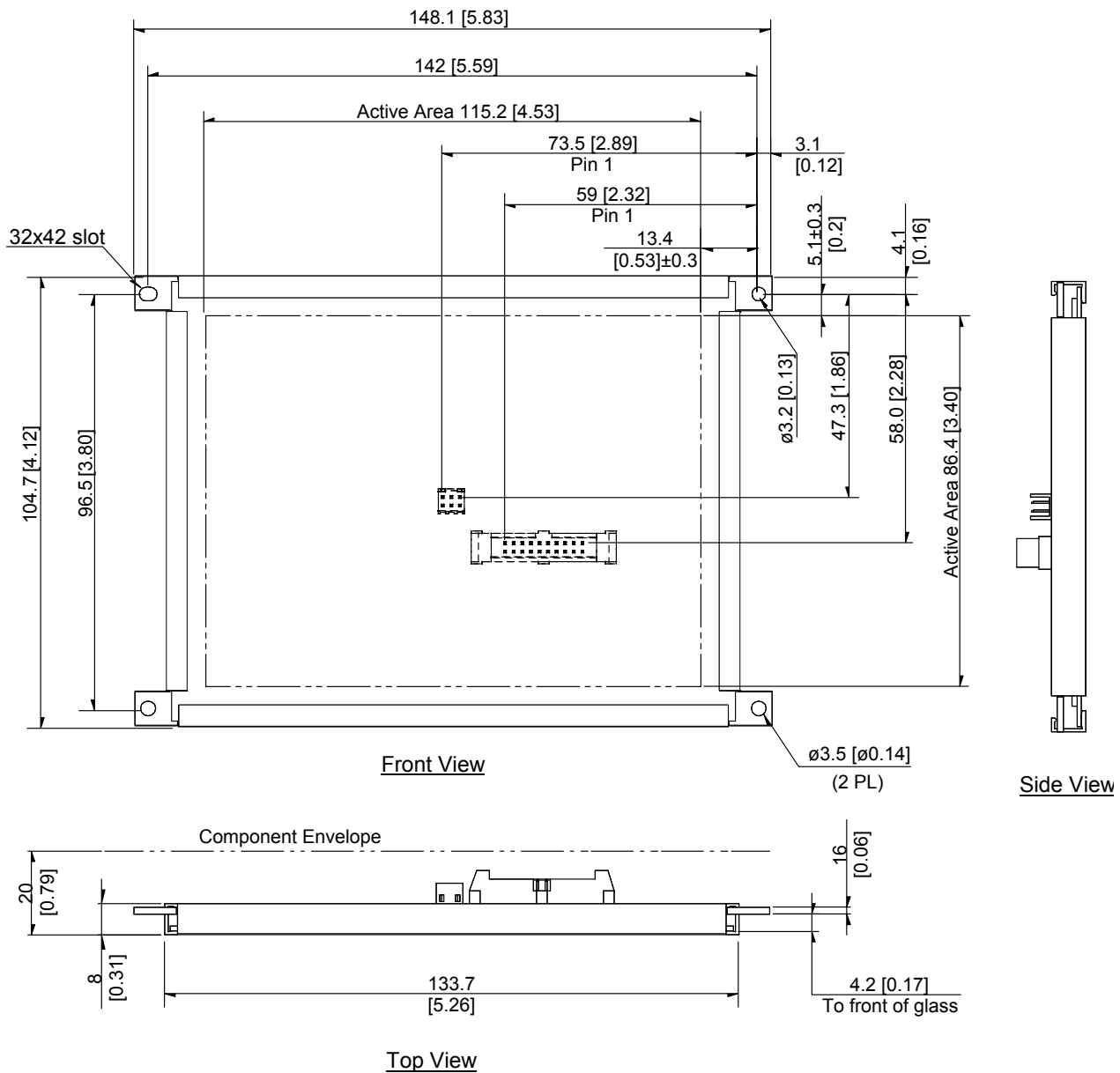

Dimensions in are millimeters; inches in brackets.

Tolerances unless specified

.x ±0.50 [0.02]

.xx ±0.25 [0.01]

Figure 4. Display Dimensions.

Note: Please refer to www.planar.com/support to view the mechanical outline drawing.

Description of Warranty

Seller warrants that the Goods will conform to published specifications and be free from defects in material for 12 months from delivery. To the extent that Goods incorporate third-party-owned software, Seller shall pass on Seller's licensor's warranty to Buyer subject to the terms and conditions of Seller's license.

Warranty repairs shall be warranted for the remainder of the original warranty period. Buyer shall report defect claims in writing to Seller immediately upon discovery, and in any event, within the warranty period. Buyer must return Goods to Seller within 30 days of Seller's receipt of a warranty claim notice and only after receiving Seller's Return Goods Authorization. Seller shall, at its sole option, repair or replace the Goods.

If Goods were repaired, altered or modified by persons other than Seller, this warranty is void. Conditions resulting from normal wear and tear and Buyer's failure to properly store, install, operate, handle or maintain the Goods are not within this warranty. Repair or replacement of Goods is Seller's sole obligation and Buyer's exclusive remedy for all claims of defects. If that remedy is adjudicated insufficient, Seller shall refund Buyer's paid price for the Goods and have no other liability to Buyer.

All warranty repairs must be performed at Seller's authorized service center using parts approved by Seller. Buyer shall pay costs of sending Goods to Seller on a warranty claim and Seller shall pay costs of returning Goods to Buyer. The turnaround time on repairs will usually be 30 working days or less. Seller accepts no added liability for additional days for repair or replacement.

If Seller offers technical support relating to the Goods, such support shall neither modify the warranty nor create an obligation of Seller. Buyer is not relying on Seller's skill or judgment to select Goods for Buyer's purposes. Seller's software, if included with Goods, is sold as is, and this warranty is inapplicable to such software.

SELLER DISCLAIMS ALL OTHER WARRANTIES, EXPRESS OR IMPLIED, INCLUDING BUT NOT LIMITED TO, IMPLIED WARRANTIES OF MERCHANTABILITY AND FITNESS FOR A PARTICULAR PURPOSE.

Ordering Information

Product	Part Number	Description
EL320.240.36 HB	996-0292-00LF	5.6" (142 mm) diagonal, quarter VGA (QVGA) high-bright display, -40 to +85°C operating temperature
EL320.240.36 HB NE	996-0292-03LF	Same as EL320.240.36 HB but with no mounting ears on the circuit board
EL320.240.36-HB NE CC	996-0292-02LF	Same as EL320.240.36 HB NE but with conformal coating added to the circuit board
EL320.240.36 HB CCB	996-0292-06LF	Same as EL320.240.36 HB but with conformal coating added to the circuit board
EL320.240.36 HB SE	996-0292-07LF	Same as EL320.240.36 HB but with two mounting ears on the circuit board instead of four

Design and specifications are subject to change without notice.

Planar Systems continues to provide optional, and in many cases custom, features to address the specific customer requirements. Consult Planar Sales for pricing, lead time and minimum quantity requirements.

Support and Service

Planar is a U.S. company based in Beaverton, Oregon and Espoo, Finland, with a world-wide sales distribution network. Full application engineering support and service are available to make the integration of Planar displays as simple and quick as possible for our customers.

RMA Procedure: For a *Returned Material Authorization* number, please contact Planar Systems, Inc. with the model number(s) and serial number(s). When returning goods for repair, please include a brief description of the problem, and mark the outside of the shipping container with the RMA number.

European Union 2002/95/EC Directive on the Restriction of Hazardous Substances (RoHS)

In February 2003, the European Union issued Directive 2002/95/EC on the Restriction of Hazardous Substances, commonly known as RoHS, in certain electrical and electronic equipment. It restricts the use of six hazardous substances, including lead (Pb).

The Directive states that all new products within its scope, placed on the European market after July 1, 2006 must be compliant with its requirements.

Planar Systems Inc. is fully in support of and compliant with EU Directive 2002/95/EC for applicable products within its scope.

Planar part number will be modified with an "LF" suffix designation to indicate RoHS compliance, as shown on the part number label affixed to the display and on the box containing the display.

Planar Systems, Inc.

Customer Service

24x7 Online Technical Support: <http://www.planar.com/support>

Americas Support

1195 NW Compton Drive

Beaverton, OR 97006-1992

Tel: 1-866-PLANAR1 (866) 752-6271

Hours: M-F, 5am - 5pm Pacific Time

Europe and Asia-Pacific Support

Olarinluoma 9 P.O. Box 46

FIN-02201 Espoo, Finland

Tel: +358-9-420-01

Hours: M-F, 7:00am - 4pm CET

© 2009 **Planar Systems, Inc. 06/09** Planar is a registered trademark of Planar Systems, Inc.

ICE, ICEBrite, and ICEPlus are trademarks of Planar Systems, Inc.

Other brands and names are the property of their respective owners.

Technical information in this document is subject to change without notice.

020-0346-00C