



These specification sheets are the proprietary product of Quanta Display Inc. ("QDI") and include materials protected under copyright of QDI. Do not reproduce or cause any third party to reproduce them in any form or by any means, electronic or mechanical, for any purpose, in whole or in part, without the express written permission of QDI.

The device listed in these technical literature sheets was designed and manufactured for use in OA equipment.

In case of using the device for applications such as control and safety equipment for transportation (aircraft, trains, automobiles, etc.), rescue and security equipment and various safety related equipment which require higher reliability and safety, take into consideration that appropriate measures such as fail-safe functions and redundant system design should be taken.

Do not use the device for equipment that requires an extreme level of reliability, such as aerospace applications, telecommunication equipment (trunk lines), nuclear power control equipment and medical or other equipment for life support.

QDI assumes no responsibility for any damage resulting from the use of the device which does not comply with the instructions and the precautions specified in these technical literature sheets.

Contact and consult with a QDI sales representative for any questions about this device.



1. Application

This specification applies to a color TFT-LCD module, QD141X1LH12.

2. Overview

This module is a color active matrix LCD module incorporating amorphous silicon TFT (Thin Film Transistor). It is composed of a color TFT-LCD panel, driver ICs, control circuit and power supply circuit and a backlight unit. Graphics and texts can be displayed on a 1024×3×768 dots panel with 262,144 colors by using LVDS (Low Voltage Differential Signaling) to interface and supplying +3.3V DC supply voltage for TFT-LCD panel driving and supply voltage for backlight.

The TFT-LCD panel used for this module has very high aperture ratio. A low-reflection and higher-color-saturation type color filter is also used for this panel. Therefore, high-brightness and high-contrast image, which is suitable for the multimedia use, can be obtained by using this module.

Optimum viewing direction is 6 o'clock.

[Features]

- 1) High aperture panel; high-brightness or low power consumption.
- 2) Brilliant and high contrast image.
- 3) Small footprint and thin shape.
- 4) Light weight.
- 5) 100% SPWG, style B

3. Mechanical Specifications

| Parameter | Specifications | Unit |
|----------------------------------|--|-------|
| Display size | 36 (14.1") Diagonal | cm |
| Active area | 285.7 (H)×214.3 (V) | mm |
| Pixel format | 1024 (H)×768 (V) | Pixel |
| | (1 pixel = R+G+B dots) | |
| Pixel pitch | 0.279 (H) × 0.279 (V) | mm |
| Pixel configuration | R,G,B vertical stripe | |
| Display mode | Normally white | |
| Unit outline dimensions (typ.)*1 | 299(W)×228 (H)×5.2(D) 5.5 Max | mm |
| Mass | Max.: 460 | g |
| Surface treatment | Anti-glare and hard-coating 3H Low reflection (~5%) | |

*1.Note : excluding backlight cables. Outline dimensions is shown in this specification



4. Input Terminals

4-1. TFT-LCD panel driving

CN1 (1 channel, LVDS signals – NSC/Ti standard and +3.3V DC power supply)

Using connector: FI-XB30Sx-HFxx/FI-X30Sx-HFxx/equivalent (JAE)

Corresponding connector: tbd

Interface Cable Pin Assignments

| PIN NO | . SYMBOL | FUNCTION |
|--------|------------|---|
| 1 | VSS | Ground |
| 2 | VDD | Power Supply, 3.3 V (typical) |
| 3 | VDD | Power Supply, 3.3 V (typical) |
| 4 | V EEDID | DDC 3.3V power |
| 5 | NC | Reserved for supplier test point |
| 6 | Clk EEDID | DDC Clock |
| 7 | DATA EEDID | DDC Data |
| 8 | Rin0- | - LVDS differential data input (R0-R5, G0) (odd pixels) |
| 9 | Rin0+ | + LVDS differential data input (R0-R5, G0) (odd pixels) |
| 10 | VSS | Ground |
| 11 | Odd Rin1- | - LVDS differential data input (G1-G5, B0-B1) (odd pixels) |
| 12 | Rin1+ | + LVDS differential data input (G1-G5, B0-B1) (odd pixels) |
| 13 | VSS | Ground |
| 14 | Rin2- | - LVDS differential data input (B2-B5, HS, VS, DE) (odd pixels) |
| 15 | Rin2+ | + LVDS differential data input (B2-B5, HS, VS, DE) (odd pixels) |
| 16 | VSS | Ground |
| 17 | ClkIN- | - LVDS differential clock input (odd pixels) |
| 18 | ClkIN+ | + LVDS differential clock input (odd pixels) |
| 19 | VSS | Ground |
| 20 | NC | No connect |
| 21 | NC | No connect |
| 22 | NC | No connect |
| 23 | NC | No connect |
| 24 | NC | No connect |
| 25 | NC | No connect |
| 26 | NC | No connect |
| 27 | NC | No connect |
| 28 | NC | No connect |
| 29 | NC | No connect |
| 30 | NC | No connect |

[Note 1] Relation between LVDS signals and actual data shows below section (4-2).

[Note 2] The shielding case is connected with signal GND.



4-2 Interface block diagram

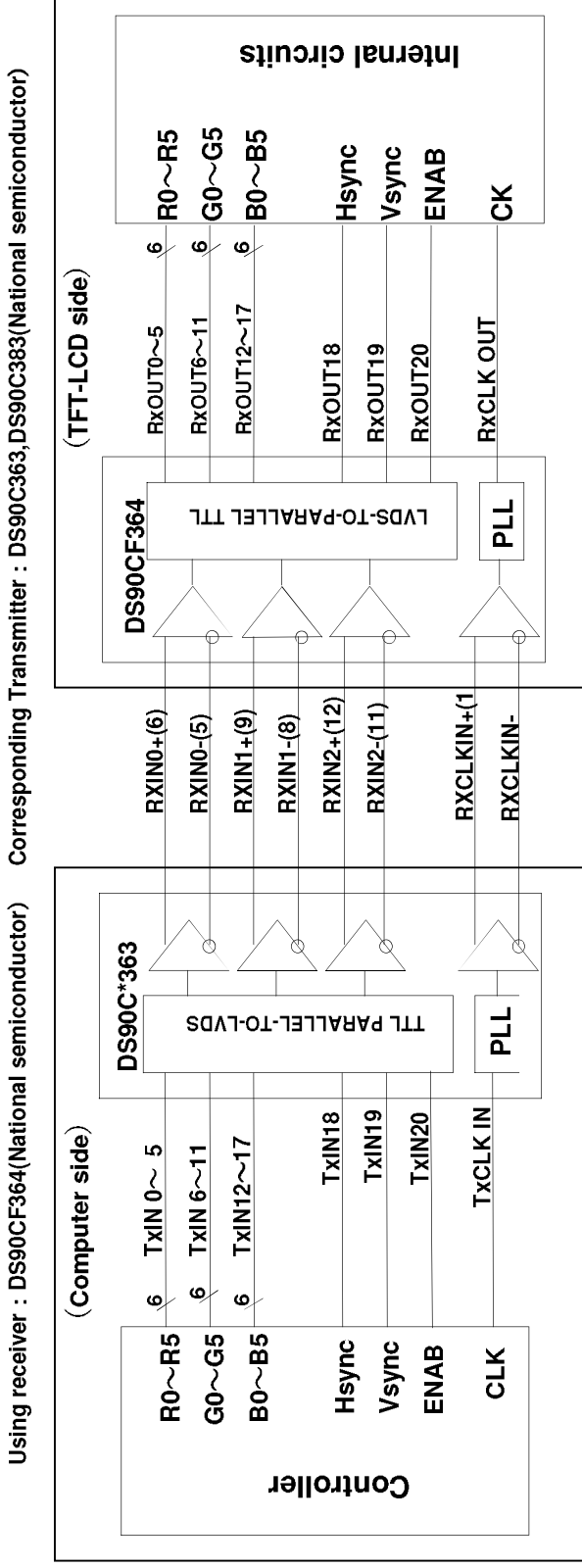



4-3. Backlight driving

CN2: BHSR-02VS-1(JST)

Mating connector: SM02B-BHSS-1-TB (JST) or 87210-0200

| Pin No. | Symbol | Function |
|---------|-------------------|--|
| 1 | V _{HIGH} | Power supply for lamp (High voltage side) |
| 2 | V _{LOW} | Power supply for lamp (Low voltage side) |

5. Absolute Maximum Ratings

5-1 LCD module

| Parameter | Symbol | Condition | Ratings | Unit | Remark |
|---------------------------------|------------------|-----------|-----------------------------|------|---------|
| Input voltage | V _I | Ta=25°C | -0.3 ~ V _{CC} +0.3 | V | 【Note1】 |
| +3.3V supply voltage | V _{CC} | Ta=25°C | 0 ~ + 4 | V | |
| Storage temperature | T _{stg} | — | -25 ~ +60 | °C | 【Note2】 |
| Operating temperature (Ambient) | T _{opa} | — | 0 ~ +50 | °C | |

【Note1】 LVDS signals

【Note2】 Humidity : 95%RH Max. at Ta≤40°C.

Maximum wet-bulb temperature at 39°C or less at Ta>40°C.

No condensation.



6. Electrical Characteristics

6-1. TFT-LCD panel driving

Ta=25°C

| Parameter | | Symbol | Min. | Typ. | Max. | Unit | Remark |
|--------------------------------------|---------------------|-------------------|------|------|------|--------|---|
| Vcc | Supply voltage | Vcc | +3.0 | +3.3 | +3.6 | V | 【Note2】 |
| | Current dissipation | Icc | — | 420 | TBD | mA | 【Note3】 |
| Permissible input ripple voltage | | V _{RP} | — | — | 100 | mV p-p | V _{CC} =+3.3V |
| Differential input Threshold voltage | High | V _{TH} | — | — | +100 | mV | V _{CM} =+1.2V 【Note1】 |
| | Low | V _{TL} | -100 | — | — | mV | |
| Input current (High) | | I _{OH} | — | — | ±10 | μA | V _I =2.4V V _{CC} =3.6V |
| Input current (Low) | | I _{OL} | — | — | ±10 | μA | V _I =0V V _{CC} =3.6V |
| Terminal resistor | | R _T | — | 100 | — | Ω | Differential input |
| Rush current | | I _{RUSH} | | | 1.5 | A | Rise time 470uS |

【Note1】 V_{CM} : Common mode voltage of LVDS driver.

【Note2】

On-off conditions for supply voltage

$0 < t1 \leq 10 \text{ ms}$

$0 < t2 \leq 50 \text{ ms}$

$0 < t3 \leq 50 \text{ ms}$

$400 \text{ms} \leq t4$

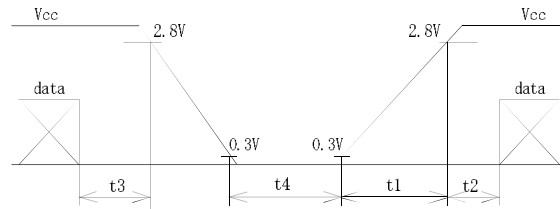

Vcc-dip conditions

1) $2.5 \text{ V} \leq V_{CC} < 3.0 \text{ V}$

$t_d \leq 10 \text{ ms}$

2) $V_{CC} < 2.5 \text{ V}$

Vcc-dip conditions should also follow the On-off conditions for supply voltage

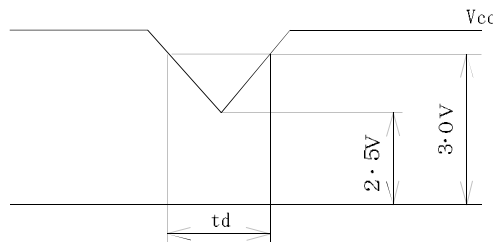

【Note3】 Typical current situation : 16-gray-bar pattern.

V_{CC}=+3.3V

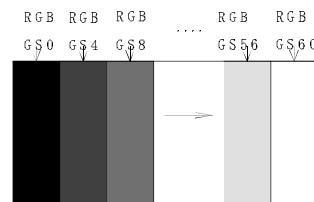



6-2. Backlight driving

The backlight system is an edge-lighting type with single CCFT (Cold Cathode Fluorescent Tube).

The characteristics of the lamp are shown in the following table.

| Parameter | Symbol | Min. | Typ. | Max. | Unit | Remark |
|------------------------|--------|-------|------|------|-------|--------------------------------------|
| Lamp current range | I_L | 2.0 | 4.0 | 6.0 | mArms | [Note1] |
| Lamp voltage | V_L | | 660 | | Vrms | |
| Lamp power consumption | P_L | — | 2.7 | — | W | [Note2] |
| Lamp frequency | F_L | 30 | 60 | 70 | kHz | [Note3] |
| Kick-off voltage | V_s | — | — | 1500 | Vrms | $T_a=25^\circ\text{C}$ |
| | | — | — | 1500 | Vrms | $T_a=0^\circ\text{C}$ [Note4] |
| Lamp life time | L_L | 10000 | — | — | hour | [Note5] |

[Note1] Lamp current is measured with current meter for high frequency as shown

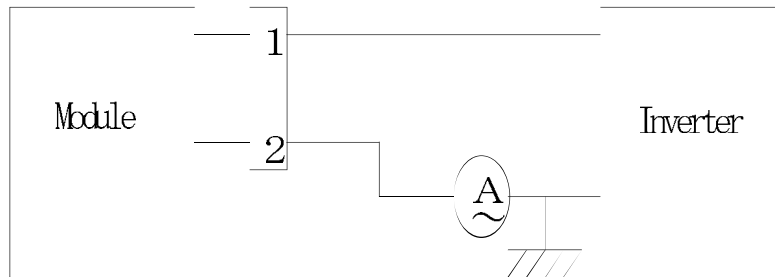

* 2pin is V_{LOW}

below.

[Note2] Calculated Value for reference ($I_L \times V_L$)

[Note3] Lamp frequency may produce interference with horizontal synchronous frequency, and this may cause beat on the display. Therefore lamp frequency shall be detached as much as possible from the horizontal synchronous frequency and from the harmonics of horizontal synchronous to avoid interference.

[Note4] It is defined at 22pF for the ballast capacitor of a DC/AC inverter.

The voltage above this value should be applied to the lamp for more than 1 second to start-up. Otherwise the lamp may not be turned on.

[Note5] Lamp life time is defined as the time when either ① or ② occurs in the continuous operation under the condition of $T_a = 25^\circ\text{C}$ and $I_L = 6.0 \text{ mArms}$.

- ① Brightness becomes 50 % of the original value under standard condition.
- ② Kick-off voltage at $T_a = 0^\circ\text{C}$ exceeds maximum value, 1500V rms.

Note) The performance of the backlight, for example life time or brightness, is much influenced by the characteristics of the DC-AC inverter for the lamp. When you design or order the inverter, please make sure that a poor lighting caused by the mismatch of the



backlight and the inverter (miss-lighting, flicker, etc.) never occur. When you confirm it, the module should be operated in the same condition as it is installed in your instrument.

7. Timing characteristics of LCD module input signals

7-1. Timing characteristics

(This is specified at digital outputs of LVDS driver.)

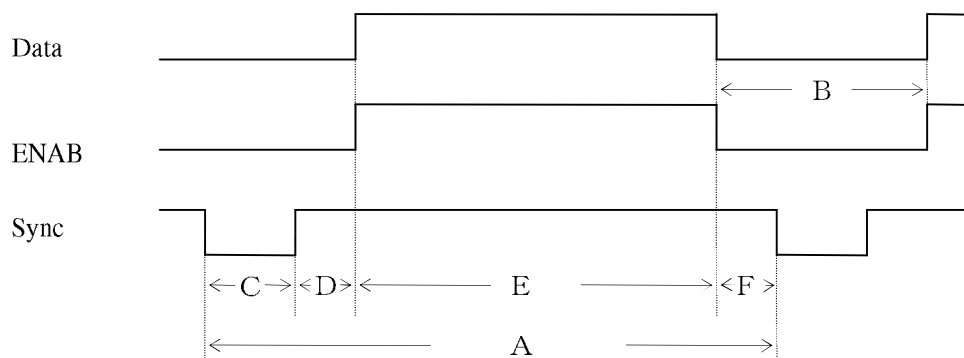

(Vertical)

| Item (symbol) | Min. | Typ. | Max. | Unit | Remark |
|---|------|--------|------|------|----------|
| Vsync cycle (T_{VA}) | — | 16.667 | — | ms | Negative |
| | 803 | 806 | | line | |
| Blanking period (T_{VB}) | 35 | 38 | — | line | |
| Sync pulse width (T_{VC}) | 4 | 6 | — | line | |
| Back porch (T_{VD}) | 0 | 29 | | line | |
| Sync pulse width + Back porch ($T_{VC}+T_{VD}$) | 35 | 35 | 35 | line | |
| Active display area (T_{VE}) | 768 | 768 | 768 | line | |
| Front porch (T_{VF}) | 0 | 3 | — | line | |

(Horizontal)

| Item (symbol) | Min. | Typ. | Max. | Unit | Remark |
|---|-----------------|--------|-----------------|---------|----------|
| Hsync cycle (T_{HA}) | 19.2 | 20.677 | — | μ S | Negative |
| | 1260 | 1344 | 1408 | clock | |
| Blanking period (T_{HB}) | 236 | 320 | — | clock | |
| Sync pulse width (T_{HC}) | 8 | 136 | — | clock | |
| Back porch (T_{HD}) | 0 | 160 | 312 | clock | |
| Sync pulse width + Back porch ($T_{HC} + T_{HD}$) | $1500 - T_{HA}$ | 296 | $T_{HA} - 1024$ | clock | |
| Active display area (T_{HE}) | 1024 | 1024 | 1024 | clock | |
| Front porch (T_{HF}) | 8 | 24 | — | clock | |

(Clock)

| Item | Min. | Typ. | Max. | Unit | Remark |
|-----------|------|------|------|------|---------|
| Frequency | — | 65.0 | 65.0 | MHz | 【Note1】 |

Note) In case of lower frequency, the deterioration of display quality, flicker etc., may be occurred.



(Hsync-Vsync Phase difference)

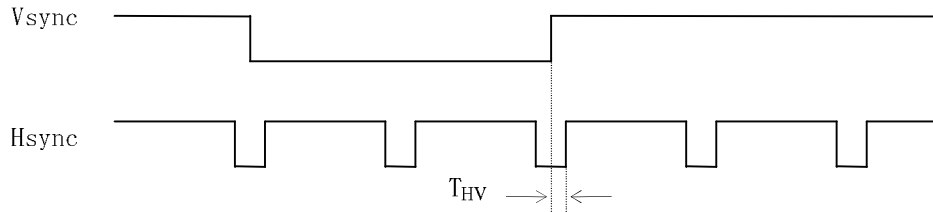

| Item(symbol) | Min. | Typ. | Max. | Unit | Remark |
|--|------|------|-----------------|-------|--------|
| Hsync-Vsync Phase difference (T_{HV}) | 1 | — | $T_{HA}-T_{HC}$ | clock | |

(Hsync-ENAB Phase difference)

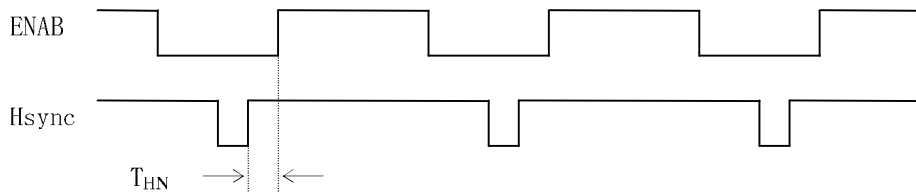

| Item | Min. | Typ. | Max. | Unit | Remark |
|--------------|------|------|------|-------|--------|
| (T_{HN}) | 0 | — | 312 | clock | |

7-2 Display position

| Item | Standards | Beginning | Ending | Unit | Remark |
|------------|----------------------|-----------|--------|-------|----------------|
| Horizontal | rising edge of ENAB | 0 | 1024 | clock | |
| | rising edge of Hsync | 296 | 1320 | clock | 【Note1】 |
| Vertical | rising edge of Vsync | 35 | 803 | clock | |

【Note1】 ENAB signal must be fixed to low.

[Note]

(Horizontal display direction)

When ENAB is fixed low, 296 clock are counted from Hsync negative edge and data from after are available . If you need other timing, please use ENAB signal.

(Vertical display direction)

35 lines are counted from Vsync negative edge and data from next line are available.

(Note of ENAB signal)

ENAB could not be used for the purpose of the vertical display start timing.

Caution

Image will not be displayed on the right position otherwise.



7-3. Input Data Signals and Display Position on the screen

Display position of input data
(H, V)



| | | | | |
|----------|--------|--------|-------|-----------------|
| D1,DH1 | D2,DH1 | D3,DH1 | | D1024,DH1 |
| D1,DH2 | D2,DH2 | | | |
| D1,DH3 | | | | |
| | | | R G B | |
| | | | | |
| D1,DH768 | | | | D1024, DH768 |



8. Input Signals, Basic Display Colors and Gray Scale of Each Color

| | Colors & | Data signal | | | | | | | | | | | | | | | | | | |
|---------------------|------------|-------------|----|----|----|----|----|----|----|----|----|----|----|----|----|----|----|----|----|----|
| | Gray scale | Gray Scale | R0 | R1 | R2 | R3 | R4 | R5 | G0 | G1 | G2 | G3 | G4 | G5 | B0 | B1 | B2 | B3 | B4 | B5 |
| Basic Color | Black | — | 0 | 0 | 0 | 0 | 0 | 0 | 0 | 0 | 0 | 0 | 0 | 0 | 0 | 0 | 0 | 0 | 0 | 0 |
| | Blue | — | 0 | 0 | 0 | 0 | 0 | 0 | 0 | 0 | 0 | 0 | 0 | 0 | 1 | 1 | 1 | 1 | 1 | 1 |
| | Green | — | 0 | 0 | 0 | 0 | 0 | 0 | 1 | 1 | 1 | 1 | 1 | 1 | 0 | 0 | 0 | 0 | 0 | 0 |
| | Cyan | — | 0 | 0 | 0 | 0 | 0 | 0 | 1 | 1 | 1 | 1 | 1 | 1 | 1 | 1 | 1 | 1 | 1 | 1 |
| | Red | — | 1 | 1 | 1 | 1 | 1 | 1 | 0 | 0 | 0 | 0 | 0 | 0 | 0 | 0 | 0 | 0 | 0 | 0 |
| | Magenta | — | 1 | 1 | 1 | 1 | 1 | 1 | 0 | 0 | 0 | 0 | 0 | 0 | 1 | 1 | 1 | 1 | 1 | 1 |
| | Yellow | — | 1 | 1 | 1 | 1 | 1 | 1 | 1 | 1 | 1 | 1 | 1 | 1 | 0 | 0 | 0 | 0 | 0 | 0 |
| | White | — | 1 | 1 | 1 | 1 | 1 | 1 | 1 | 1 | 1 | 1 | 1 | 1 | 1 | 1 | 1 | 1 | 1 | 1 |
| Gray Scale of Red | Black | GS0 | 0 | 0 | 0 | 0 | 0 | 0 | 0 | 0 | 0 | 0 | 0 | 0 | 0 | 0 | 0 | 0 | 0 | 0 |
| | ↑ | GS1 | 1 | 0 | 0 | 0 | 0 | 0 | 0 | 0 | 0 | 0 | 0 | 0 | 0 | 0 | 0 | 0 | 0 | 0 |
| | Darker | GS2 | 0 | 1 | 0 | 0 | 0 | 0 | 0 | 0 | 0 | 0 | 0 | 0 | 0 | 0 | 0 | 0 | 0 | 0 |
| | ↑ | ↓ | | | | ↓ | | | | ↓ | | | | ↓ | | | | | | |
| | ↓ | ↓ | | | | ↓ | | | | ↓ | | | | ↓ | | | | | | |
| | Brighter | GS61 | 1 | 0 | 1 | 1 | 1 | 1 | 0 | 0 | 0 | 0 | 0 | 0 | 0 | 0 | 0 | 0 | 0 | 0 |
| | ↓ | GS62 | 0 | 1 | 1 | 1 | 1 | 1 | 0 | 0 | 0 | 0 | 0 | 0 | 0 | 0 | 0 | 0 | 0 | 0 |
| | Red | GS63 | 1 | 1 | 1 | 1 | 1 | 1 | 0 | 0 | 0 | 0 | 0 | 0 | 0 | 0 | 0 | 0 | 0 | 0 |
| Gray Scale of Green | Black | GS0 | 0 | 0 | 0 | 0 | 0 | 0 | 0 | 0 | 0 | 0 | 0 | 0 | 0 | 0 | 0 | 0 | 0 | 0 |
| | ↑ | GS1 | 0 | 0 | 0 | 0 | 0 | 0 | 1 | 0 | 0 | 0 | 0 | 0 | 0 | 0 | 0 | 0 | 0 | 0 |
| | Darker | GS2 | 0 | 0 | 0 | 0 | 0 | 0 | 0 | 1 | 0 | 0 | 0 | 0 | 0 | 0 | 0 | 0 | 0 | 0 |
| | ↑ | ↓ | | | | ↓ | | | | ↓ | | | | ↓ | | | | | | |
| | ↓ | ↓ | | | | ↓ | | | | ↓ | | | | ↓ | | | | | | |
| | Brighter | GS61 | 0 | 0 | 0 | 0 | 0 | 0 | 1 | 0 | 1 | 1 | 1 | 1 | 0 | 0 | 0 | 0 | 0 | 0 |
| | ↓ | GS62 | 0 | 0 | 0 | 0 | 0 | 0 | 0 | 1 | 1 | 1 | 1 | 1 | 0 | 0 | 0 | 0 | 0 | 0 |
| | Green | GS63 | 0 | 0 | 0 | 0 | 0 | 0 | 1 | 1 | 1 | 1 | 1 | 1 | 0 | 0 | 0 | 0 | 0 | 0 |
| Gray Scale of Blue | Black | GS0 | 0 | 0 | 0 | 0 | 0 | 0 | 0 | 0 | 0 | 0 | 0 | 0 | 0 | 0 | 0 | 0 | 0 | 0 |
| | ↑ | GS1 | 0 | 0 | 0 | 0 | 0 | 0 | 0 | 0 | 0 | 0 | 0 | 0 | 1 | 0 | 0 | 0 | 0 | 0 |
| | Darker | GS2 | 0 | 0 | 0 | 0 | 0 | 0 | 0 | 0 | 0 | 0 | 0 | 0 | 0 | 1 | 0 | 0 | 0 | 0 |
| | ↑ | ↓ | | | | ↓ | | | | ↓ | | | | ↓ | | | | | | |
| | ↓ | ↓ | | | | ↓ | | | | ↓ | | | | ↓ | | | | | | |
| | Brighter | GS61 | 0 | 0 | 0 | 0 | 0 | 0 | 0 | 0 | 0 | 0 | 0 | 0 | 1 | 0 | 1 | 1 | 1 | 1 |
| | ↓ | GS62 | 0 | 0 | 0 | 0 | 0 | 0 | 0 | 0 | 0 | 0 | 0 | 0 | 0 | 1 | 1 | 1 | 1 | 1 |
| | Blue | GS63 | 0 | 0 | 0 | 0 | 0 | 0 | 0 | 0 | 0 | 0 | 0 | 0 | 1 | 1 | 1 | 1 | 1 | 1 |

0 : Low level voltage, 1 : High level voltage

Each basic color can be displayed in 64 gray scales from 6 bit data signals. According to the



combination of total 18 bit data signals, the 262,144-color display can be achieved on the screen.

9. Optical Characteristics

Ta=25°C, Vcc=+3.3V

| Parameter | | Symbol | Condition | Min. | Typ. | Max. | Unit | Remark |
|-------------------------------|------------|------------------------|-----------------------|-------|-------|-------|-------------------|---|
| Viewing Angle Range | Horizontal | $\theta 21, \theta 22$ | CR>10 | 40 | — | — | Deg. | 【Note1,4】 |
| | Vertical | $\theta 11$ | | 10 | — | — | Deg. | |
| | | $\theta 12$ | | 30 | — | — | Deg. | |
| Contrast ratio | | CRn | $\theta = 0^\circ$ | 300 | — | — | | 【Note2,4】 |
| | | CRo | Optimum viewing angle | 300 | — | — | | |
| Response Time | Rise | τr | $\theta = 0^\circ$ | — | 12.5 | — | ms | 【Note3,4】 |
| | Decay | τd | | — | 22.5 | — | ms | |
| Chromaticity of White | | x | | 0.285 | 0.315 | 0.345 | | 【Note4】 |
| | | y | | 0.300 | 0.330 | 0.360 | | |
| Luminance of white 【Note4】 | | Y_{L1} | Center | | 120 | — | Cd/m ² | $I_L = 4.0\text{mArms}$ $F_L = 60\text{kHz}$ |
| | | Y_{L2} | | 120 | 160 | — | Cd/m ² | $I_L = 6.0\text{mArms}$ $F_L = 60\text{kHz}$ |
| White Uniformity | | δ_w | 13 Points | — | — | 1.53 | | 【Note5】 |
| White Uniformity | | δ_w | 5 Points | — | — | 1.25 | | 【Note5】 |

※ The measurement shall be executed 30 minutes after lighting at rating.
(typical condition : $I_L = 4.0 \text{ mArms}$)

The optical characteristics shall be measured in a dark room or equivalent state with the method shown in Fig.3.

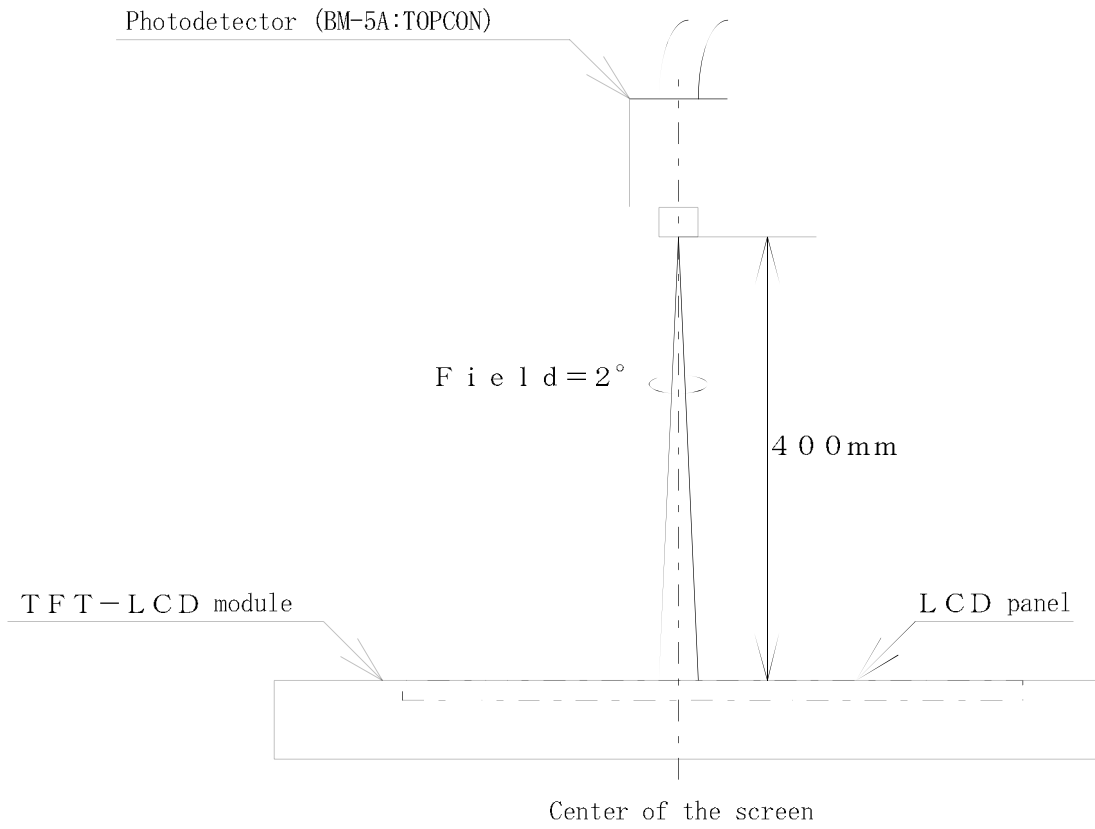
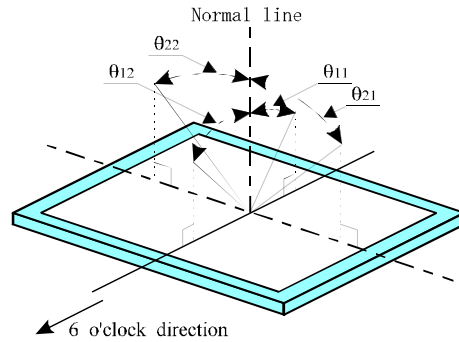

Fig.3 Optical characteristics measurement method



[Note1] Definitions of viewing angle range:



[Note2] Definition of contrast ratio:

The contrast ratio is defined as the following.

$$\text{Contrast Ratio (CR)} = \frac{\text{Luminance (brightness) with all pixels white}}{\text{Luminance (brightness) with all pixels black}}$$

[Note3] Definition of response time:

The response time is defined as the following figure and shall be measured by switching the input signal for "black" and "white" .

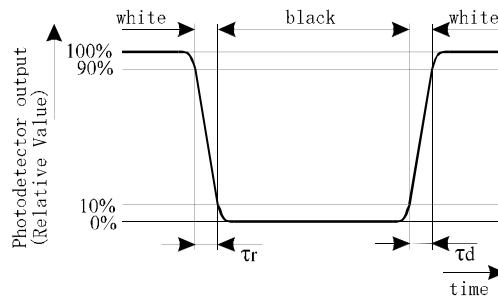

[Note4] This shall be measured at center of the screen.

[Note5] Definition of white uniformity:

Maximum Luminance of 5/13 points

$$\delta w = \frac{\text{Maximum Luminance of 5/13 points}}{\text{Minimum Luminance of 5/13 points}}$$

(5 Points A,B,C,D,E

13 Points A,B,C,D,E,F,G,H,I,J,K,L,M)

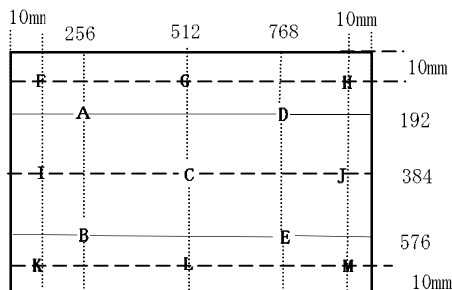

**10. Display Quality**

The display quality of the color TFT-LCD module shall be in compliance with the Incoming Inspection Standard.

11. Handling Precautions

- a) Be sure to turn off the power supply when inserting or disconnecting the cable.
- b) Be sure to design the cabinet so that the module can be installed without any extra stress such as warp or twist.
- c) Since the front polarizer is easily damaged, pay attention not to scratch it.
- d) Wipe off water drop immediately. Long contact with water may cause discoloration or spots.
- e) When the panel surface is soiled, wipe it with absorbent cotton or other soft cloth.
- f) Since the panel is made of glass, it may break or crack if dropped or bumped on hard surface. Handle with care.
- g) Since CMOS LSI is used in this module, take care of static electricity and injure the human earth when handling.
- h) Observe all other precautionary requirements in handling components.
- i) This module has its circuitry PCBs on the rear side and should be handled carefully in order not to be stressed.
- j) Laminated film is attached to the module surface to prevent it from being scratched . Peel the film off slowly just before the use with strict attention to electrostatic charges. Ionized air shall be blown over during the action. Blow off the 'dust' on the polarizer by using an ionized nitrogen gun, etc..
- K) Black PET sheet covers some electric components and handle with special care to avoid mechanical stress and shock on this PET surface.
- L) Mounting screw hole can stand torque 1.3~1.5 Kgf-cm.



12. Reliability test items

| No. | Test item | Conditions |
|-----|---|---|
| 1 | High temperature storage test | Ta = 60°C 240h |
| 2 | Low temperature storage test | Ta = -25°C 240h |
| 3 | High temperature & high humidity operation test | Ta = 40°C ; 95 %RH 240h (No condensation) |
| 4 | High temperature operation test | Ta = 50°C 240h (The panel temp. must be less than 60°C) |
| 5 | Low temperature operation test | Ta = 0°C 240h |
| 6 | Vibration test (non- operating) | Frequency: 10 ~ 57Hz/Vibration width (one side):0.075mm : 58~500Hz/Gravity:9.8m/s ² Sweep time : 11 minutes Test period : 3 hours (1 hour for each direction of X,Y,Z) |
| 7 | Shock test (non- operating) | Max. gravity : 490 m/s ² Pulse width : 11 ms, sine wave Direction : ±X,±Y,±Z once for each direction. |

13. Others

1) Lot No. Label:

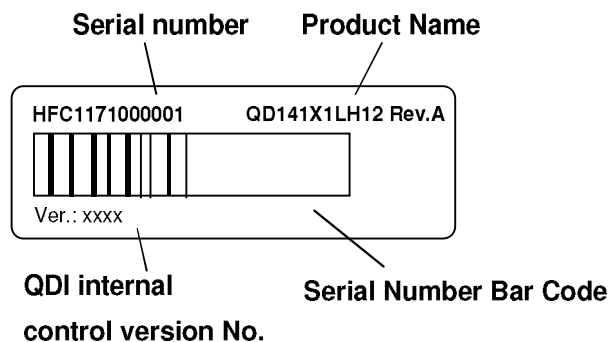

- 2) Adjusting volume has been set optimally before shipment, so do not change any adjusted value. If adjusted value is changed, the specification may not be satisfied.
- 3) Disassembling the module can cause permanent damage and should be strictly avoided.
- 4) Please be careful since image retention may occur when a fixed pattern is displayed for a long time.
- 5) If any problem occurs in relation to the description of this specification, it shall be resolved through discussion with spirit of cooperation.