

Prepared by: Date
12/12/2003

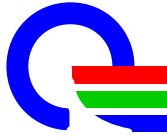

Doc. No. QD17TT02

Doc. Rev. :03

Issue Date :03/31//2004

Page: 25 pages
(Include cover page)

P r e l i m i n a r y

**Quanta Display Inc.
SPECIFICATION**

Specification for
TFT LCD Module
Model No.
QD17TT02 Rev:01

Customer's Approval

Date _____

by _____

Approved

By _____



These specification sheets are the proprietary product of Quanta Display Inc. ("QDI") and include materials protected under copyright of QDI. Do not reproduce or cause any third party to reproduce them in any form or by any means, electronic or mechanical, for any purpose, in whole or in part, without the express written permission of QDI.

The device listed in these technical literature sheets was designed and manufactured for use in OA equipment.

In case of using the device for applications such as control and safety equipment for transportation (aircraft, trains, automobiles, etc.), rescue and security equipment and various safety related equipment which require higher reliability and safety, take into consideration that appropriate measures such as fail-safe functions and redundant system design should be taken.

Do not use the device for equipment that requires an extreme level of reliability, such as aerospace applications, telecommunication equipment (trunk lines), nuclear power control equipment and medical or other equipment for life support.

QDI assumes no responsibility for any damage resulting from the use of the device, which does not comply with the instructions, and the precautions specified in these technical literature sheets.

Contact and consult with a QDI sales representative for any questions about this device.



Content List

	Page
1. Application	4
2. Overview	4
3. General Specifications	4
4. Input Terminals	5
5. Absolute Maximum Ratings	7
6. Electrical Characteristics	8
7. Timing Characteristics	10
8. Input Signals, Basic Display Colors and Gray Scale of Each Color	12
9. Optical Characteristics	13
10. Display Quality	16
11. Handling Precautions	16
12. Reliability Test Items	17
13. Others	17
14. Attachment	18



1. Application

This specification applies to a color TFT-LCD module, QD17TT01.

2. Overview

This module is a color active matrix LCD module incorporating amorphous silicon TFT (Thin Film Transistor). It is composed of a color TFT-LCD panel; driver ICs, control circuit and power supply circuit and a backlight unit. Graphics and texts can be displayed on a $1440 \times 3 \times 900$ dots panel with 262,144 colors by using TMDS (Transition Minimized Differential Signaling) to interface and supplying +3.3V DC supply voltage for TFT-LCD panel driving.

The TFT-LCD panel used for this module has very high aperture ratio. A low-reflection and higher-color-saturation type color filter is also used for this panel. Therefore, high-brightness and high-contrast image, which is suitable for the multimedia use, can be obtained by using this module.

Optimum viewing direction is 6 o'clock.

[Features]

- 1) High aperture panel; high-brightness or low power consumption.
- 2) Brilliant and high contrast image.
- 3) Small footprint and thin shape.
- 4) WXGA resolution.
- 5) TMDS interface.
- 6) Low power consumption.
- 7) Wide viewing angle.
- 8) 6 bits

3. General Specifications

Parameter	Specifications	Unit
Display size	17.1" Diagonal	inch
Active area	367.2 (H) × 229.5 (V)	mm
Pixel format	1440 (H) × 900 (V)	Pixel
	(1 pixel = R+G+B dots)	
Pixel pitch	0.255 (H) × 0.255 (V)	mm
Pixel configuration	R,G,B vertical stripe	
Display mode	Normally White	
Unit outline dimensions (typ.)*1	395.0 × 256.4 × 10.5	mm
Weight	1200 Max.	g
Surface treatment	Anti-glare and hard-coating 3H Low reflection (~5%)	
Lamp Quantity	2	pcs

*1.Note : excluding backlight cables.

Outline dimensions is shown in Fig.1



4. Input Terminals

4-1. TFT-LCD panel driving

CN1 (TMDS signals and +3.3V DC power supply)

Using connector: FI-XB30SL-HF10 (JAE)

Pin No.	Symbol	Function	Remark
1	GND	Ground	
2	GND	Ground	
3	RX2+	TMDS Low Voltage Differential Signal Input Data 2(+)	TMDS
4	RX2-	TMDS Low Voltage Differential Signal Input Data 2(-)	TMDS
5	GND	Ground	
6	RX1+	TMDS Low Voltage Differential Signal Input Data 1(+)	TMDS
7	RX1-	TMDS Low Voltage Differential Signal Input Data 1(-)	TMDS
8	GND	Ground	
9	RX0+	TMDS Low Voltage Differential Signal Input Data 0(+)	TMDS
10	RX0-	TMDS Low Voltage Differential Signal Input Data 0(-)	TMDS
11	GND	Ground	
12	RXC+	TMDS Low Voltage Differential Signal Input Data C(+)	TMDS
13	RXC-	TMDS Low Voltage Differential Signal Input Data C(-)	TMDS
14	GND	Ground	
15	VEDID	DDC Power Supply 3.3V	
16	NC	NC	
17	CLK-EDID	DDC Clock	
18	DATA-EDID	DDC Data	
19	GND	Ground	
20	GND	Ground	
21	GND	Ground	
22	VCC	Power Supply 3.3V	
23	VCC	Power Supply 3.3V	
24	VCC	Power Supply 3.3V	
25	NC	NC	
26	NC	NC	
27	NC	NC	
28	GND	Ground	
29	NC	NC	
30	NC	NC	

[Note 1] All GND(ground) pins should be connected together and to Vss which should also be connected to the LCDs metal frame.

[Note 2] Relation between TMDS signals and actual data shows below section (4-2).

[Note 3] All Vcc(power supply) pins should be connected together.



4-2 Interface block diagram

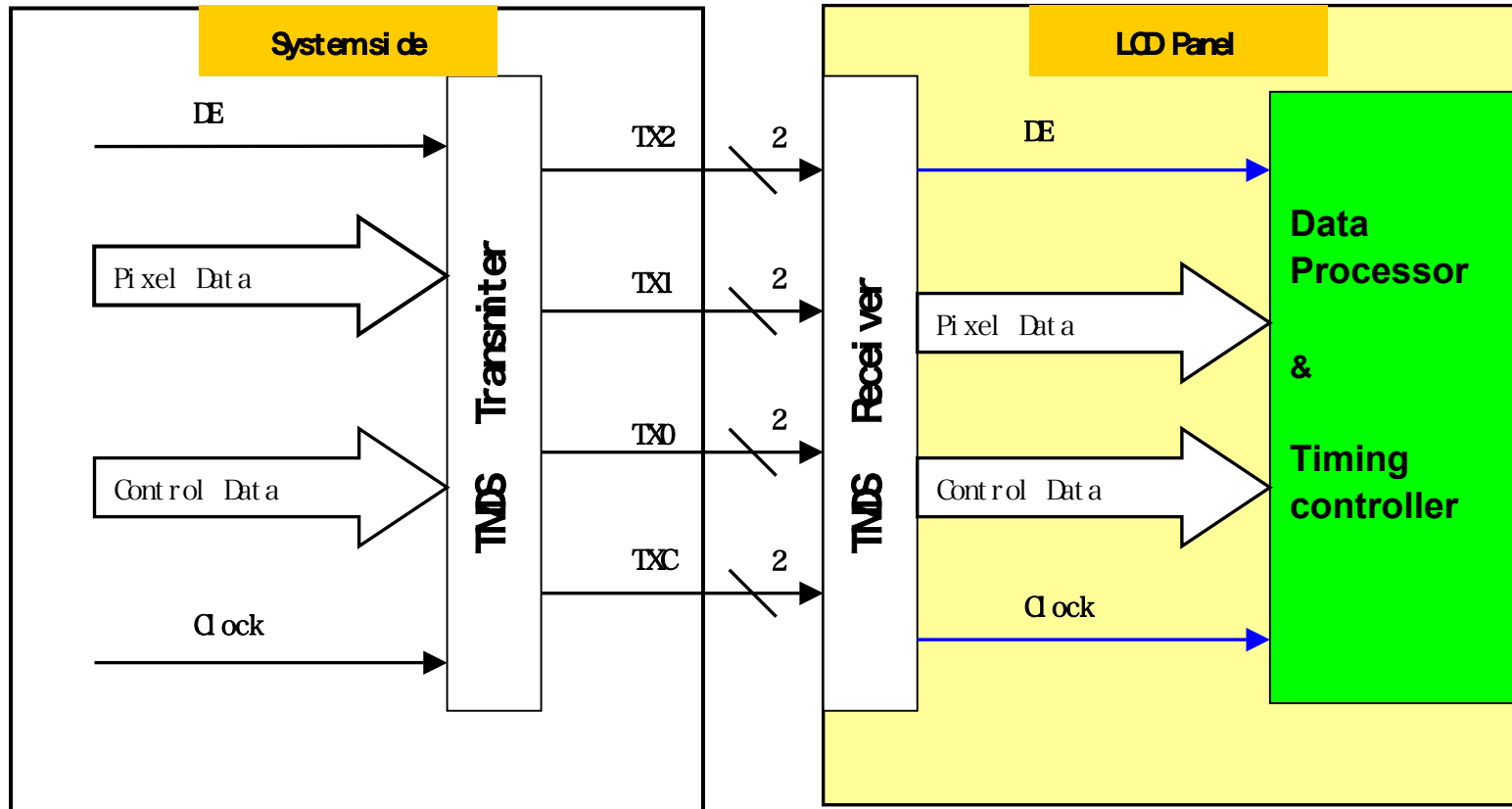



4-3. Backlight driving

CN 2, 3: BHSR-02VS-1 (JST)

Mating connector: SM02B-BHSS-1 (JST)

Pin No.	Symbol	Function
1	V _{High}	High voltage side
2	V _{GND}	Ground

5. Absolute Maximum Ratings

LCD module

Parameter	Symbol	Condition	Ratings	Unit	Remark
+3.3V Input Voltage	V _{CC}	T _a =25°C	- 0.3 ~ +3.6	V _{DC}	
Storage temperature	T _{stg}	—	-20 ~ +60	°C	【Note1】
Operating temperature (Ambient)	T _{opa}	—	0 ~ +50	°C	

【Note1】 Humidity : 90%RH Max. at T_a ≤ 40°C.

Maximum wet-bulb temperature at 39°C or less at T_a > 40°C.

No condensation.



6. Electrical Characteristics

6-1. TFT-LCD panel driving

Ta=25°C

Parameter		Symbol	Min.	Typ.	Max.	Unit	Remark
V _{CC}	Supply voltage	V _{CC}	+3.0	+3.3	+3.6	V	【Note1】
	Current dissipation	I _{DD}	—	988	1100	m A	【Note2】
Permissible input ripple voltage		V _{RP}	—	—	100	mV p-p	V _{CC} =+3.45V
Inrush current		I _{RUSH}			1.2	A	

【Note1】

On-off conditions for supply voltage

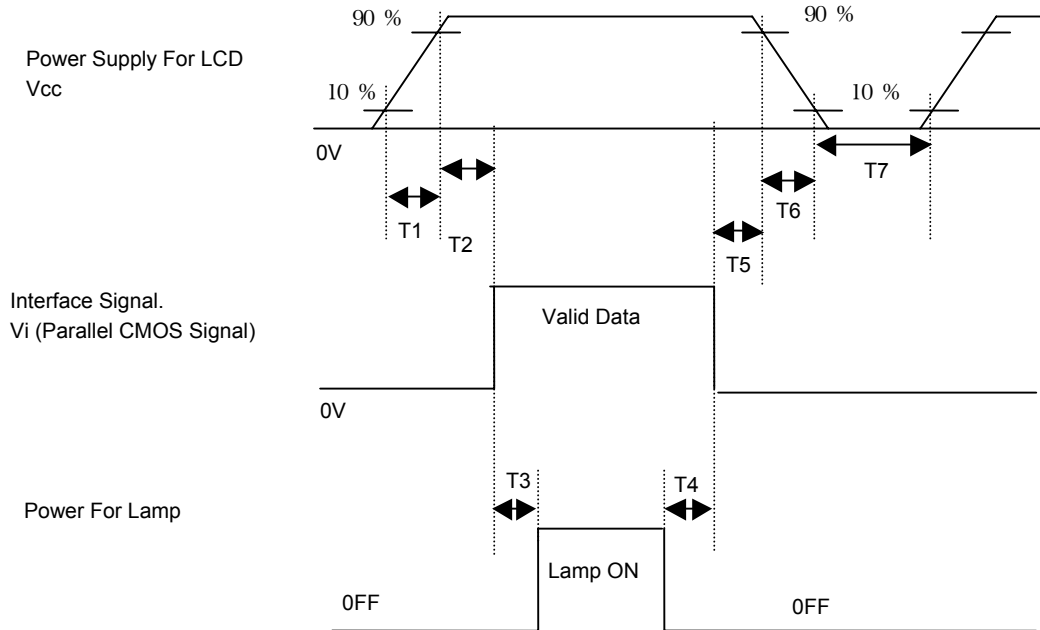

$0 < t_1 \leq 10 \text{ ms}$; $0.5 < t_2 \leq 50 \text{ ms}$; $200 \text{ ms} \leq t_3$; $200 \text{ ms} \leq t_4$; $0.5 < t_5 \leq 50 \text{ ms}$; $0 < t_6 \leq 10 \text{ ms}$; $400 \text{ ms} < t_7$

【Note2】 Typical current situation : Black pattern. V_{CC}=+3.3V



6-2. Backlight driving

The backlight system is an edge-lighting type with 2 CCFT (Cold Cathode Fluorescent Tube).

The characteristics of the lamp are shown in the following table.

Parameter	Symbol	Min.	Typ.	Max.	Unit	Remark
Lamp current range	I_L	2.5	8.0	9.0	mArms	【Note1】
Lamp voltage	V_L	639	710	781	Vrms	
Lamp power consumption	P_L		5.68		W	【Note2】 $I_L=8.0\text{mA}$
Lamp frequency	F_L	50		60	kHz	【Note3】
Established starting voltage	V_s			1440	Vrms	$T_a=25^\circ\text{C}$
		—	—	1670	Vrms	$T_a=0^\circ\text{C}$ 【Note4】
Lamp life time	L_L	40000	—	—	hour	【Note5】

【Note1】 Lamp current is measured with current meter for high frequency as shown below.

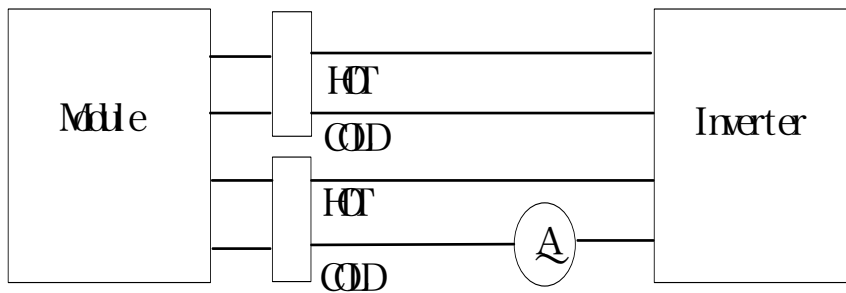

【Note2】 Calculated Value for reference ($I_L \times V_L$)

【Note3】 Lamp frequency may produce interference with horizontal synchronous frequency, and this may cause beat on the display. Therefore lamp frequency shall be detached as much as possible from the horizontal synchronous frequency and from the harmonics of horizontal synchronous to avoid interference.

【Note4】 The voltage should be applied to the both ends of the lamp for more than 1 second to start-up. Otherwise the lamp may not be turned on.

【Note5】 Lamp life time is defined as the time when either ① or ② occurs in the continuous operation under the condition of $T_a = 25^\circ\text{C}$ and $I_L = 8.0 \text{ mArms}$.

- ① Brightness becomes 50 % of the original value under standard condition.
- ② Established starting voltage at $T_a = 0^\circ\text{C}$ exceeds maximum value.

Note) The performance of the backlight, for example life time or brightness, is much influenced by the characteristics of the DC-AC inverter for the lamp. When you design or order the inverter, please make sure that a poor lighting caused by the mismatch of the backlight and the inverter (miss-lighting, flicker, etc.) never occur. When you confirm it, the module should be operated in the same condition as it is installed in your instrument.

7. Timing characteristics of LCD module input signals



7-1. Timing characteristics

ITIME	Symbol		Min	Typ	Max	Unit	Notes
DCLK	Frequency	f_{CLK}	96.21	96.21	96.21	MHz	
	Period	t_{CLK}	10.39	10.39	10.39	ns	
Hsync	Period	t_{HP}	1760	1760	1760	t_{CLK}	1
	Width-Active	t_{WH}	32	32	32		2
Vsync	Frequency	t_{VSY}	59.939	59.939	59.939	Hz	3
	Period	t_{VP}	912	912	912	t_{HP}	
	Width-Active	t_{WV}	3	3	3		4
Data Enable	Horizontal back porch	t_{HBP}	224	224	224	t_{CLK}	
	Horizontal front porch	t_{HFP}	64	64	64	t_{CLK}	
	Horizontal active Data	t_{HA}	1440	1440	1440	t_{CLK}	
	Vertical back porch	t_{VBP}	6	6	6	t_{HP}	
	Vertical front porch	t_{VFP}	3	3	3	t_{HP}	
	Vertical active data	t_{VA}	900	900	900	t_{HP}	

Notes: 1.Hsync period shall be a double number of 8

2. Horizontal sync shall be active high

3. Vertical frequency is only 60Hz

4. Vertical sync shall be active high

7-2 Signal Timing Waveforms



DCLK, Data Enable, Hsync, Vsync, data

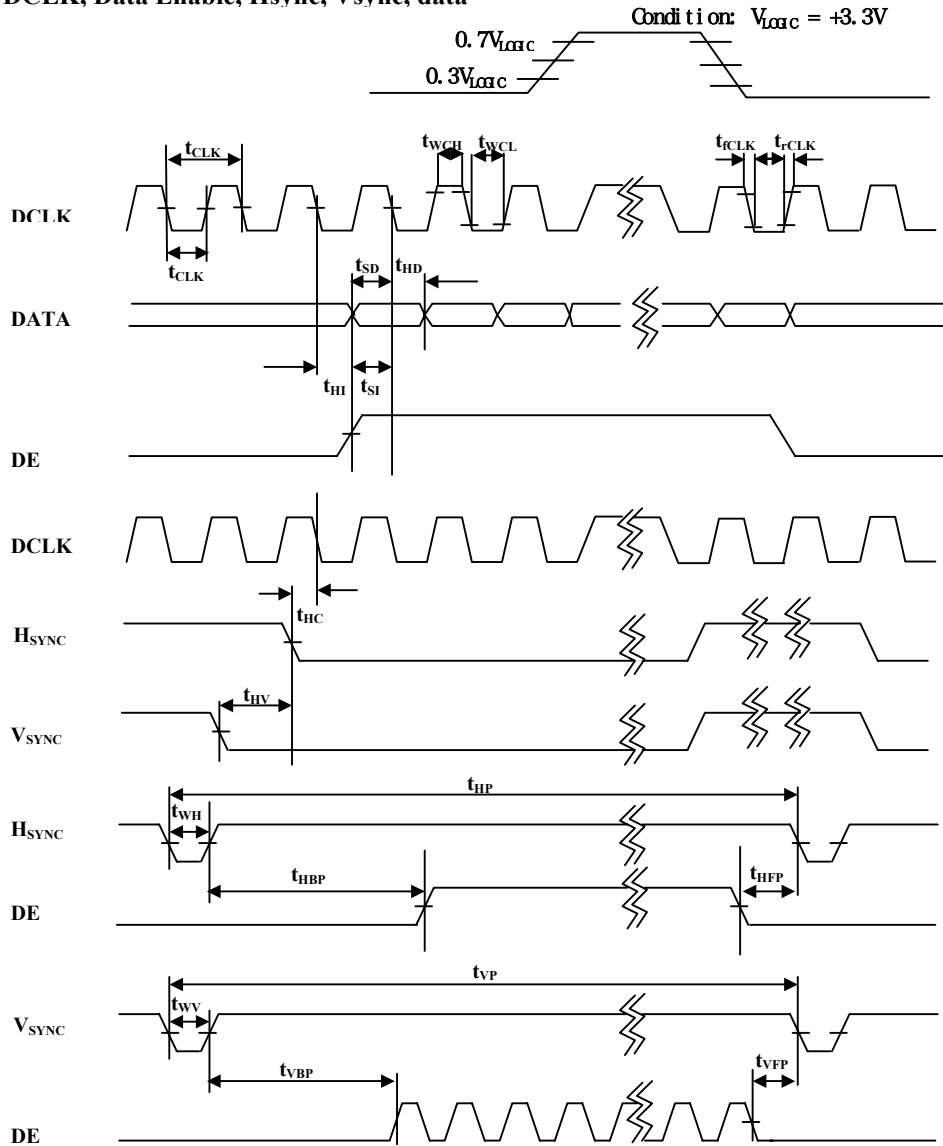

7-3. Input Data Signals and Display Position on the screen

Display position of input data
(H , V)

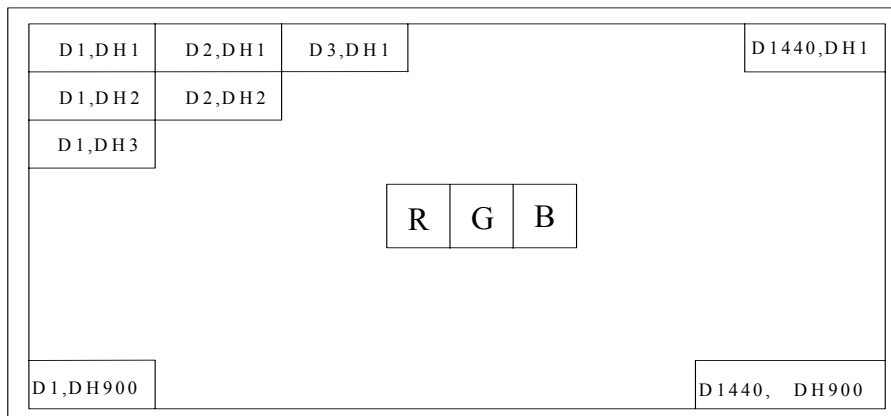



8. Input Signals, Basic Display Colors and Gray Scale of Each Color

	Colors & Gray scale	Data Signal																		
		Gray Scale	R0	R1	R2	R3	R4	R5	G0	G1	G2	G3	G4	G5	B0	B1	B2	B3	B4	B5
Basic Color	Black	--	0	0	0	0	0	0	0	0	0	0	0	0	0	0	0	0	0	0
	Blue	--	0	0	0	0	0	0	0	0	0	0	0	0	1	1	1	1	1	1
	Green	--	0	0	0	0	0	0	1	1	1	1	1	1	0	0	0	0	0	0
	Cyan	--	0	0	0	0	0	0	1	1	1	1	1	1	1	1	1	1	1	1
	Red	--	1	1	1	1	1	1	0	0	0	0	0	0	0	0	0	0	0	0
	Magenta	--	1	1	1	1	1	1	0	0	0	0	0	0	1	1	1	1	1	1
	Yellow	--	1	1	1	1	1	1	1	1	1	1	1	1	0	0	0	0	0	0
	White	--	1	1	1	1	1	1	1	1	1	1	1	1	1	1	1	1	1	1
Gray Scale of Red	Black	GS0	0	0	0	0	0	0	0	0	0	0	0	0	0	0	0	0	0	0
	↑	GS1	1	0	0	0	0	0	0	0	0	0	0	0	0	0	0	0	0	0
	Darker	GS2	0	1	0	0	0	0	0	0	0	0	0	0	0	0	0	0	0	0
	↑	↓				↓					↓					↓				
	↓	↓				↓					↓					↓				
	Brighter	GS61	1	0	1	1	1	1	0	0	0	0	0	0	0	0	0	0	0	0
	↓	GS62	0	1	1	1	1	1	0	0	0	0	0	0	0	0	0	0	0	0
	Red	GS63	1	1	1	1	1	1	0	0	0	0	0	0	0	0	0	0	0	0
Gray Scale of Green	Black	GS0	0	0	0	0	0	0	0	0	0	0	0	0	0	0	0	0	0	0
	↑	GS1	0	0	0	0	0	0	1	0	0	0	0	0	0	0	0	0	0	0
	Darker	GS2	0	0	0	0	0	0	0	1	0	0	0	0	0	0	0	0	0	0
	↑	↓				↓					↓					↓				
	↓	↓				↓					↓					↓				
	Brighter	GS61	0	0	0	0	0	0	1	0	1	1	1	1	0	0	0	0	0	0
	↓	GS62	0	0	0	0	0	0	0	1	1	1	1	1	0	0	0	0	0	0
	Green	GS63	0	0	0	0	0	0	1	1	1	1	1	1	0	0	0	0	0	0
Gray Scale of Blue	Black	GS0	0	0	0	0	0	0	0	0	0	0	0	0	0	0	0	0	0	0
	↑	GS1	0	0	0	0	0	0	0	0	0	0	0	0	1	0	0	0	0	0
	Darker	GS2	0	0	0	0	0	0	0	0	0	0	0	0	0	1	0	0	0	0
	↑	↓				↓					↓					↓				
	↓	↓				↓	↓				↓	↓				↓				
	Brighter	GS61	0	0	0	0	0	0	0	0	0	0	0	0	1	0	1	1	1	1
	↓	GS62	0	0	0	0	0	0	0	0	0	0	0	0	0	1	1	1	1	1
	Blue	GS63	0	0	0	0	0	0	0	0	0	0	0	0	1	1	1	1	1	1

0 : Low level voltage, 1 : High level voltage

Each basic color can be displayed in 64 gray scales from 6 bit data signals. According to the combination of total 18 bit data signals, the 262,144 color display can be achieved on the screen.



9. Optical Characteristics

Ta=25°C, V_{CC}=+3.3V

Parameter		Symbol	Condition	Min.	Typ.	Max.	Unit	Remark
Viewing angle range	Horizontal	$\theta 21, \theta 22$	CR>10	60	70		Deg.	【Note1,4】
	Vertical	$\theta 11$		55	65		Deg.	
		$\theta 12$		50	60		Deg.	
Contrast ratio		C R n	$\theta =0^\circ$	300	450	—		【Note2,4】
Response time		τ	$\theta =0^\circ$	—	25		ms	【Note3,4】
Rise time		τr			5	10	ms	
Fall time		τd			20	25	ms	
Chromaticity of White (CIE 1931)	W _x			0.283	0.313	0.343		【Note4】
	W _y			0.299	0.329	0.359		
Chromaticity of Red (CIE 1931)	R _x			0.592	0.622	0.652		
	R _y			0.307	0.337	0.367		
Chromaticity of Green (CIE 1931)	G _x			0.274	0.304	0.334		
	G _y			0.548	0.578	0.608		
Chromaticity of Blue (CIE 1931)	B _x			0.116	0.146	0.176		
	B _y			0.070	0.100	0.130		
Luminance of white 【Note4】		Y _L		180	250		Cd/m ²	I _L = 8.0mArms
White Uniformity		δw		—	—	1.25		【Note5】

※ The measurement shall be executed 30 minutes after lighting at rating. (typical condition :
I_L = 8.0 mArms)

The optical characteristics shall be measured in a dark room or equivalent state with the method

shown in Fig.3 below.

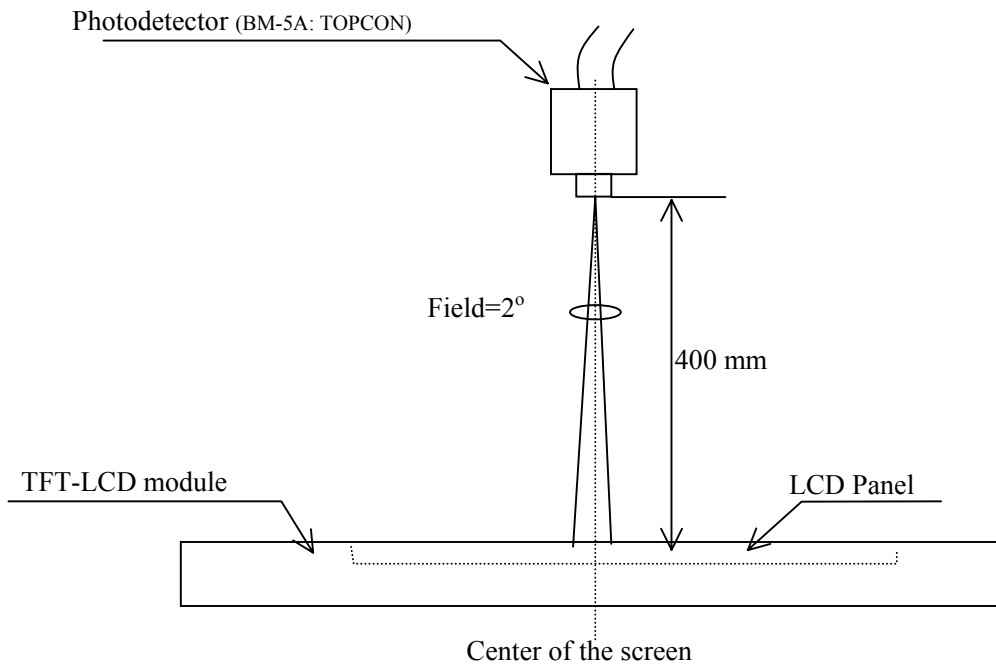
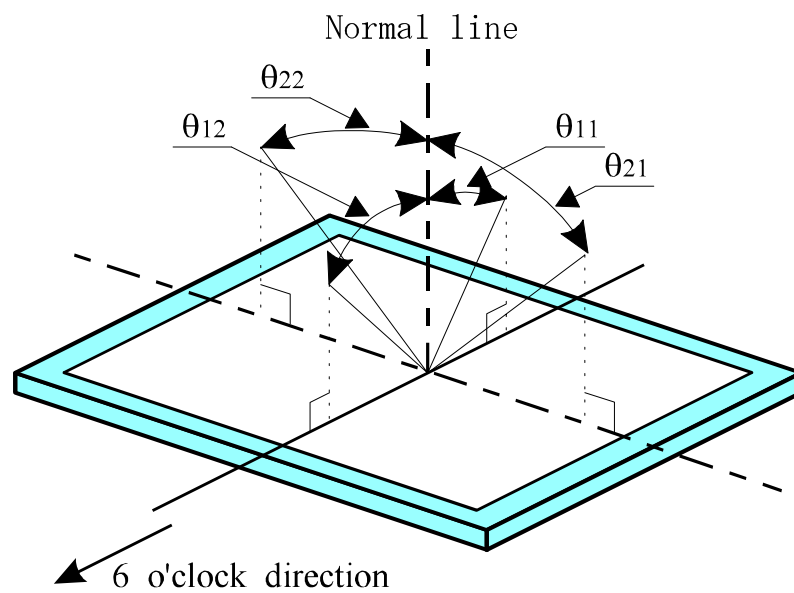

Fig 3. Optical characteristics measurement method

【Note1】 Definitions of viewing angle range:



【Note2】 Definition of contrast ratio:

The contrast ratio is defined as the following.

$$\text{Contrast Ratio (CR)} = \frac{\text{Luminance (brightness) with all pixels white}}{\text{Luminance (brightness) with all pixels black}}$$

【Note3】 Definition of response time:



The response time is defined as the following figure and shall be measured by switching the input signal for "black" and "white" .

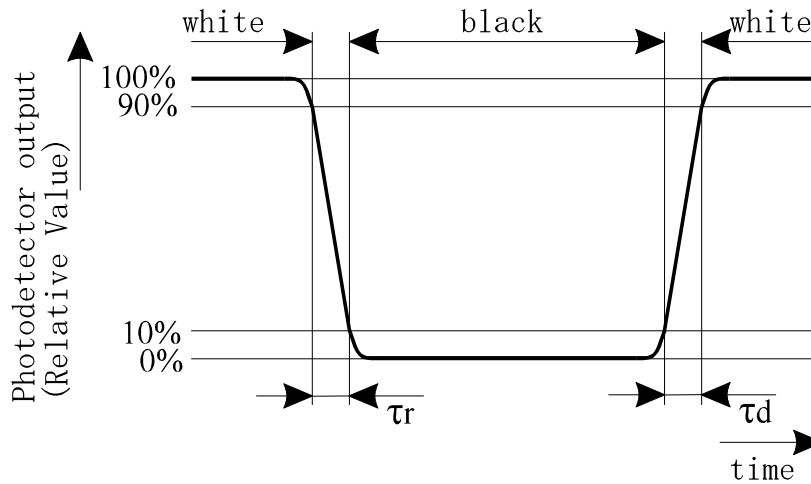

[Note4] This shall be measured at center of the screen.

[Note5] Definition of white uniformity:

White uniformity is defined as the following with 5 measurements (A~E).

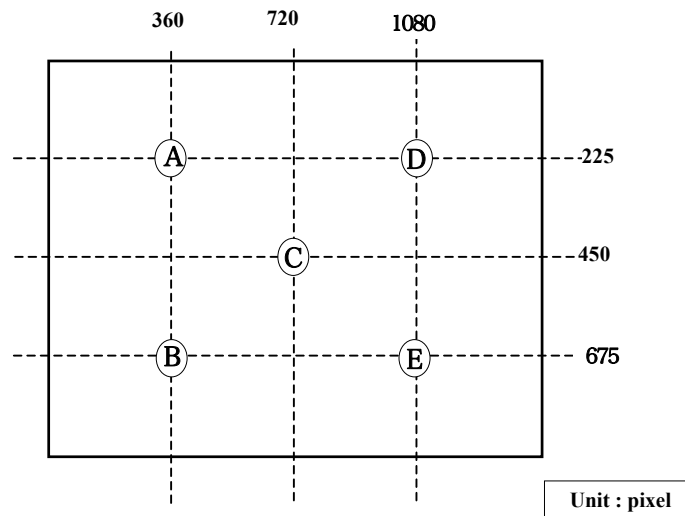

$$\delta_w = \frac{\text{Maximum Luminance} - \text{Minimum Luminance (of 5 points measurement)}}{\text{Average Luminance of 5 points}}$$



10. Display Quality

The display quality of the color TFT-LCD module shall be in compliance with the Incoming Inspection Standard.

11. Handling Precautions

- a) Be sure to turn off the power supply when inserting or disconnecting the cable.**
- b) Be sure to design the cabinet so that the module can be installed without any extra stress such as warp or twist.**
- c) Since the front polarizer is easily damaged, pay attention not to scratch it.**
- d) Wipe off water drop immediately. Long contact with water may cause discoloration or spots.**
- e) When the panel surface is soiled, wipe it with absorbent cotton or other soft cloth.**
- f) Since the panel is made of glass, it may break or crack if dropped or bumped on hard surface. Handle with care.**
- g) Since CMOS LSI is used in this module, take care of static electricity and injure the human earth when handling.**
- h) Observe all other precautionary requirements in handling components.**
- i) This module has its circuitry PCBs on the rear side and should be handled carefully in order not to be stressed.**
- j) Laminated film is attached to the module surface to prevent it from being scratched . Peel the film off slowly just before the use with strict attention to electrostatic charges. Ionized air shall be blown over during the action. Blow off the 'dust' on the polarizer by using an ionized nitrogen gun, etc..**



12. Reliability test items

No.	Test item	Conditions
1	High temperature storage test	Ta = 60°C 240h
2	Low temperature storage test	Ta = -20°C 240h
3	High temperature & high humidity operation test	Ta = 40°C ; 95 %RH 240h (No condensation)
4	High temperature operation test	Ta = 50°C 240h (The panel temp. must be less than 60°C)
5	Low temperature operation test	Ta = 0°C 240h
6	Vibration test (non- operating)	Frequency:10~500Hz/1G Test period: 3 hours (1 hour for each direction of X,Y,Z)
7	Shock test (non- operating)	Max. gravity: 490 m/s ² Pulse width: 11 ms, sine wave Direction : ±X,±Y,±Z Once for each direction.

13. Others

1) Lot No. Label:

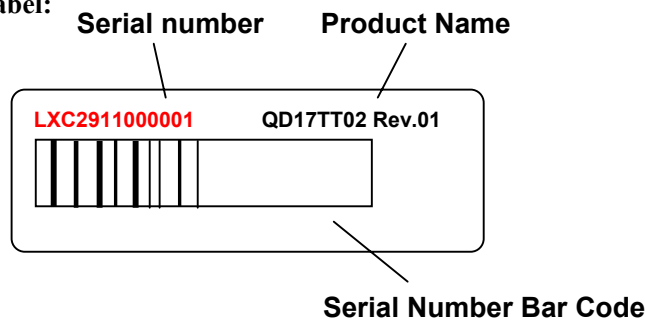

LXC225100001 Digital code 4, 5 is Date code.

Digital 4 (Year) 1: 2001, 2: 2002, 3:2003,....

Digital 5 (Month) 1: Jan, 2: Feb,... , A:Oct, B:Nov., C: Dec.

- 2) Adjusting volume has been set optimally before shipment, so do not change any adjusted value. If adjusted value is changed, the specification may not be satisfied.
- 3) Disassembling the module can cause permanent damage and should be strictly avoided.
- 4) Please be careful since image retention may occur when a fixed pattern is displayed for a long time.
- 5) If any problem occurs in relation to the description of this specification, it shall be resolved through discussion with spirit of cooperation.



14. Attachment

Incoming Inspection Standards for TFT-LCD Modules

1) Scope

These incoming inspection standards shall apply to TFT-LCD modules (hereinafter called "Module") supplied by QDI Corporation (hereinafter called "Seller") to Quanta (hereinafter called the "Buyer").

2) Incoming inspection

The Buyer shall have the right to conduct at its own cost and expense, an incoming inspection of the Module's at the destination specified in the relevant bills of landing in accordance with the Module's specifications separately agreed upon and the inspection standard set forth in this Article. The Buyer shall notify the Seller writing of a result of such inspection judgment (acceptance or rejection) in accordance with the said inspection standard within 40 days after the date of the bills of landing. Should the Buyer fail to so notify the seller within the said 40 days period, the Buyer's right to reject the Module's shall then lapse, and the said Module's shall be deemed to have been accepted by the Buyer.

3) Method of incoming inspection

Unless otherwise agreed in writing, the method of incoming inspection shall be in accordance with a sampling inspection based on MIL-STD-105E.

4) Classification of defects

Defects are classified as major defect and a minor defect according to the degree of defect defined herein.

a) Major defect

A major defect is a defect that is likely to result in failure, or to reduce materially the usability of the product for its intended purpose.

b) Minor defect

A minor defect either is a defect that is not likely to reduce materially the usability of the product for its intended purpose, or is a departure from an established having little bearing on the effective use or operation of the product.

Specific criteria of judgment on major and/or minor defects or otherwise shall be in accordance with the attached "Classification of Defect."

5) Acceptable quality level ("AQL")

The AQL for major and minor defects shall be respectively set forth below.

- a) Major defects: AQL : 0.4%



b) **Minor defects: AQL: 1% Based on overall evaluation**

6) Method of sampling inspection

- a) **Lot size : Quantity per shipment lot per mode**
- b) **Sampling type : Normal inspection, Single sampling**
- c) **Inspection level : II**
- d) **Sampling table : Table in MIL-STD-105E**
- e) **Inspection conditions : The inspection conditions shall be as in the LCD specifications. The environmental conditions and the visual inspection shall be as follows:**
 - (i) **The environmental conditions**
Room temperature: 20-25°C
Humidity: 65±20%RH
 - (ii) **The external visual inspection: The inspection shall be conducted by using a single 20W fluorescent lamp for illumination and the distance between the MODULE and the eyes of the inspection shall be 35CM±5CM.**

7) Determination of acceptability and subsequent disposal

If the number of defects found in the sample Module's from the lot is equal to or less than the applicable acceptance level, the lot shall be accepted.

If the number of defects is greater than the applicable acceptance level, the lot shall be rejected. The Buyer shall inform the Seller of detailed result of such inspection within the time period stipulated in Article 2.

The disposal is as follows:

a) Accepted lot

An acceptance under the above incoming inspection shall constitute an acceptance by the Buyer of such lot of the Module's in terms of the landed quality thereof.

b) Rejected lot

If a lot of PRODUCTS is rejected under the above incoming inspection due to any defects for which the Seller is responsible and such a fact is clearly confirmed by the Sellers, the Seller shall exercise one of the following three options. This must be determined with mutual consent and shall be confirmed by the Seller. The best choice of the options shall be left to the Seller's discretion and the Seller shall advise the Buyer of its choice not later than two weeks of receipt of the Buyer's advance:

- (1) **The Buyer shall return the defective lot to the place to be designated by the Seller and Seller shall screen all of the PRODUCTS in the lot and repair defective PRODUCTS.**



- (2) The Seller shall screen all of the PRODUCTS in the lot and repair defective products within a reasonable time period at the Buyer's facility.
- (3) The Buyer shall screen the entire lot for the good modules at the expense of the Seller to be separately agreed upon. The rejected PRODUCTS shall be returned to the place to be designated by the Seller.

8) External inspection

Inspection item	Criteria	Reject count(N)
Black spot ,White spot, Foreign circular Material Dent &bubble	$D > 0.5\text{mm}$	$N \geq 1$
	$D \geq 0.15\text{mm}$	$N \geq 4$
	$D < 0.15\text{mm}$	Don't care
	Minimum distance between defects :10mm	
Scratches ,lint L:length; W:width(mm)	$L > 3.0\text{mm} ; W > 0.1\text{mm}$	$N \geq 1$

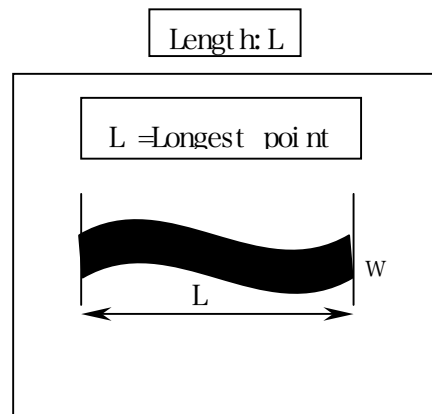
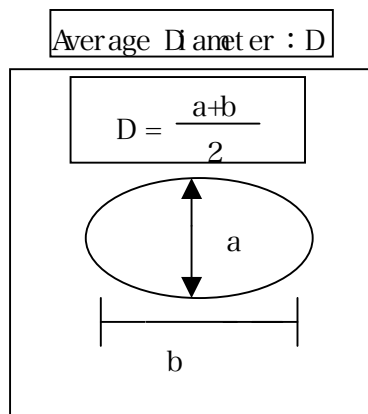

*1 The external visual inspection: The inspection shall be conducted by using a single 20W fluorescent lamp for illumination and the distance between the MODULE and the eyes of the inspector shall be 35 cm or more.

* The area for external inspection is active area plus 1.0mm width. (Upper, Lower, Left and Right)



9) Dot defect

(1) Inspection Conditions [Visual inspection]

- Viewing distance : 35 cm
- Ambient illumination : 300 to 700Lux (Standard 500Lux)
- Ambient temperature : 20-25°C
- Light source condition : Based on the specification

Note: Viewing angle : The surface of the MODULE and the eyes of the inspector shall be 90 degrees.

(2) Definition

a) Bright dot

The sub-pixel can be seen when using the 5% ND-Filter

b) Scratches on the color filter (Bright dot count)

- Count: defect area > 1/4 dot
- No count: defect area < 1/4 dot

(3) Bright dots (Acceptable)

Green/Red/Blue dots : When the MODULE lights, dots appear bright in display at black picture position.(V0)

Check pattern	Total Quantity
Black picture Position	≤ 3

- 2 adjacent 1 pair MAX
- Green Bright dots 2 adjacent Nothing
- Defect distance more than 15mm

(4) Black dots (Acceptable)

Black dots : When the MODULE lights, dots appear black in display at Green+Blue+Red picture position.

Check pattern	Total
Green+Blue+Red Picture position	Three picture position total 6 MAX

- Two adjacent dots 2 pair MAX
- Defect distance more than 5mm
- Three joined bright dots must be nil

**(5) Total dot defect (Black & Bright)**

Check pattern	Total Quantity
N/A	6 MAX

10) Display non-uniformity/ Mura

There should be no distinct non-uniformity/ Mura visible through 5% transparency of filter.

Viewing distance : 35cm

Ambient illumination : 300 to 700 Lux(standard 500Lux)

Ambient temperature : 20-25°C

Light source condition : Based on the specification.

Note : Viewing angle : The surface of the Module and the eyes of the inspector shall be 90 degrees.

11) Others

If some problems arise about mentioned items in this document and other items, the user of the TFT-LCD module and QDI will cooperate and make efforts to solve the problems with mutual respect and good will.

D17W Outline

Front view

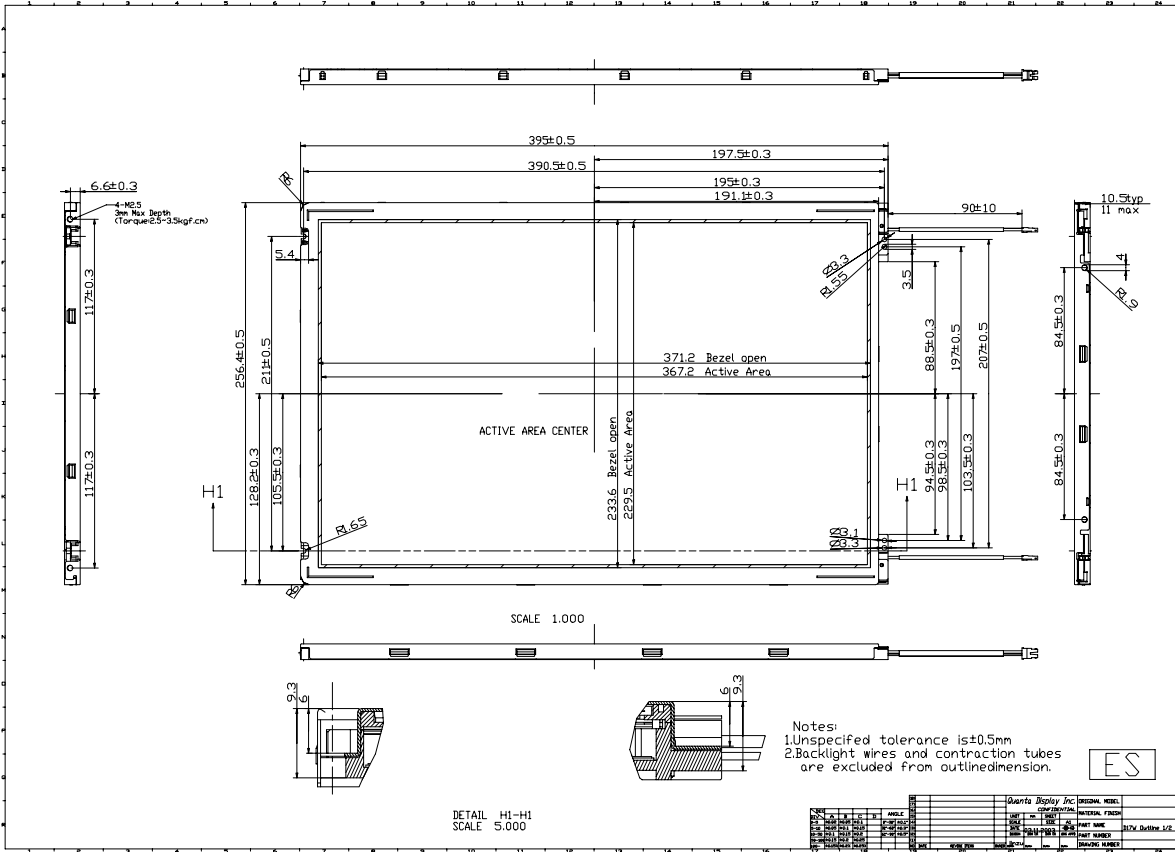

Rear view

