

LQ201U1LW01

TFT-LCD Module

(Model Number: LQ201U1LW01)

Specifications

Spec No.: LD-14115

Dated: May 29, 2002

PREPARED BY : DATE	<h1>SHARP</h1> <p>TFT LCD DEVELOPMENT GROUP SHARP CORPORATION</p> <h2>SPECIFICATION</h2>	SPEC No. LD-14115
APPROVED BY : DATE		FILE No.
		ISSUE : Feb.25.2002
		PAGE : 24 pages
		APPLICABLE GROUP TFT Liquid Crystal Display Group

DEVICE SPECIFICATION
TFT-LCD Module
 MODEL No.
LQ201U1LW01

CUSTOMER'S APPROVAL

DATE _____

BY _____

PRESENTED

BY _____

M. TAKEDA
 Department General Manager
 Development Engineering Department 2
 AVC Liquid Crystal Display Division
 AVC Liquid Crystal Display Group
 SHARP Corporation

1. Application

This specification applies to the color 20.1 UXGA TFT-LCD module LQ201U1LW01.

- ◎These specification sheets are the proprietary product of SHARP CORPORATION("SHARP) and include materials protected under copyright of SHARP. Do not reproduce or cause any third party to reproduce them in any form or by any means, electronic or mechanical, for any purpose, in whole or in part, without the express written permission of SHARP.
- ◎The device listed in these specification sheets was designed and manufactured for use in OA equipment.
- ◎In case of using the device for applications such as control and safety equipment for transportation(aircraft, trains, automobiles, etc.), rescue and security equipment and various safety related equipment which require higher reliability and safety, take into consideration that appropriate measures such as fail-safe functions and redundant system design should be taken.
- ◎In case of using the device for equipment that requires an extreme level of reliability, such as aerospace applications, telecommunication equipment(trunk lines), nuclear power control equipment and medical or other equipment for life support, contact and consult with a SHARP sales representative.
- ◎SHARP assumes no responsibility for any damage resulting from the use of the device which does not comply with the instructions and the precautions specified in these specification sheets.
- ◎Contact and consult with a SHARP sales representative for any questions about this device.

2. Overview

This module is a color active matrix LCD module incorporating amorphous silicon TFT (Thin Film Transistor). It is composed of a color TFT-LCD panel, driver ICs, control circuit, power supply circuit and a back light unit. Graphics and texts can be displayed on a 1600×3×1200 dots panel with about 16 million colors by supplying 48 bit data signals(8bit×2pixel×RGB) , two display enable signals, two dot clock signals, +12V DC supply voltages for TFT-LCD panel driving and supply voltage for back light.

It is a wide viewing-angle-module (Vertical viewing angle:170° Horizontal viewing angle:170° ,CR≥10).

3. Mechanical Specifications

Parameter	Specifications	Unit
Display size	51 (Diagonal)	cm
	20.1 (Diagonal)	Inch
Active area	408.0 (H) × 306.0 (V)	mm
Pixel format	1600 (H) × 1200 (V)	Pixel
	(1 pixel = R + G + B dots)	
Pixel pitch	0.255(H) × 0.255 (V)	mm
Pixel configuration	R,G,B vertical stripe	
Display mode	Normally black	
Unit outline dimensions *1	436(W) × 335 (H) × 27.5 (D)	mm
Mass	3.8 (MAX)	kg
Surface treatment	Anti-glare And hard-coating 2H	

*1.Note: excluding back light cables.

The thickness of module (D) doesn't contain the projection.

Outline dimensions are shown in Fig.1.

4. Input Terminals

4-1. TFT-LCD panel driving

CN7A,CN7B (Interface signals and +12VDC power supply)

Using connectors : DF19G-20P-1H (Hirose Electric Co., Ltd.)

Corresponding connectors : DF19G-20S-1C (Hirose Electric Co., Ltd.)

DF19G-20S-1F (Hirose Electric Co., Ltd.)

Using LVDS receiver : Contained in a control IC

Corresponding LVDS transmitter : THC63LVDM83R(Thine) or compatible

CN 7 A

Pin No.	Symbol	Function	Remark
1	Vcc	+12V power supply	
2	Vcc	+12V power supply	
3	Vss	Gnd	
4	Vss	Gnd	
5	RAIN0-	Negative (-) LVDS differential data input (A port)	LVDS
6	RAIN0+	Positive (+) LVDS differential data input (A port)	LVDS
7	Vss	Gnd	
8	RAIN1-	Negative (-) LVDS differential data input (A port)	LVDS
9	RAIN1+	Positive (+) LVDS differential data input (A port)	LVDS
10	Vss	Gnd	
11	RAIN2-	Negative (-) LVDS differential data input (A port)	LVDS
12	RAIN2+	Positive (+) LVDS differential data input (A port)	LVDS
13	Vss	Gnd	
14	CKAIN-	Negative (-) LVDS differential clock input (A port)	LVDS
15	CKAIN+	Positive (+) LVDS differential clock input (A port)	LVDS
16	Vss	Gnd	
17	RAIN3-	Negative (-) LVDS differential data input (A port)	LVDS
18	RAIN3+	Positive (+) LVDS differential data input (A port)	LVDS
19	Vss	Gnd	
20	BLON	Back light ON signal (output) 【Note1】	Pull Up

【Note1】 BLON:It change from L to H at 7 frames after Vcc ON.

CN 7 B

Pin No.	Symbol	Function	Remark
1	Vcc	+12V power supply	
2	Vcc	+12V power supply	
3	Vss	Gnd	
4	Vss	Gnd	
5	RBIN0-	Negative (-) LVDS differential data input (B port)	LVDS
6	RBIN0+	Positive (+) LVDS differential data input (B port)	LVDS
7	Vss	Gnd	
8	RBIN1-	Negative (-) LVDS differential data input (B port)	LVDS
9	RBIN1+	Positive (+) LVDS differential data input (B port)	LVDS
10	Vss	Gnd	
11	RBIN2-	Negative (-) LVDS differential data input (B port)	LVDS
12	RBIN2+	Positive (+) LVDS differential data input (B port)	LVDS
13	Vss	Gnd	
14	CKBIN-	Negative (-) LVDS differential clock input (B port)	LVDS
15	CKBIN+	Positive (+) LVDS differential clock input (B port)	LVDS
16	Vss	Gnd	
17	RBIN3-	Negative (-) LVDS differential data input (B port)	LVDS
18	RBIN3+	Positive (+) LVDS differential data input (B port)	LVDS
19	Vss	Gnd	
20	SELLVDS	Select LVDS data order 【Note2】	Pull Up

【Note2】 This module has dual pixel port to receive dual pixel data at the same time . A port receives first pixel data and B port receives second pixel data in dual pixel data.

【Note2】 SELLVDS(Thine:THC63LVDM83R)

Transmitter		SELLVDS	
Pin No	Data	=L	=H
51	TA0	R0(LSB)	R2
52	TA1	R1	R3
54	TA2	R2	R4
55	TA3	R3	R5
56	TA4	R4	R6
3	TA5	R5	R7(MSB)
4	TA6	G0(LSB)	G2
6	TB0	G1	G3
7	TB1	G2	G4
11	TB2	G3	G5
12	TB3	G4	G6
14	TB4	G5	G7(MSB)
15	TB5	B0(LSB)	B2
19	TB6	B1	B3
20	TC0	B2	B4
22	TC1	B3	B5
23	TC2	B4	B6
24	TC3	B5	B7(MSB)
27	TC4	(NA)	(NA)
28	TC5	(RSV1)	(RSV1)
30	TC6	DE	DE
50	TD0	R6	R0(LSB)
2	TD1	R7(MSB)	R1
8	TD2	G6	G0(LSB)
10	TD3	G7(MSB)	G1
16	TD4	B6	B0(LSB)
18	TD5	B7(MSB)	B1
25	TD6	(NA)	(NA)

4-2 Interface block diagram

Using receiver : Contained in a control IC.

Corresponding Transmitter : THC63LVDM83R(Thine electronics),DS90C383,DS90C383A(National semiconductor)

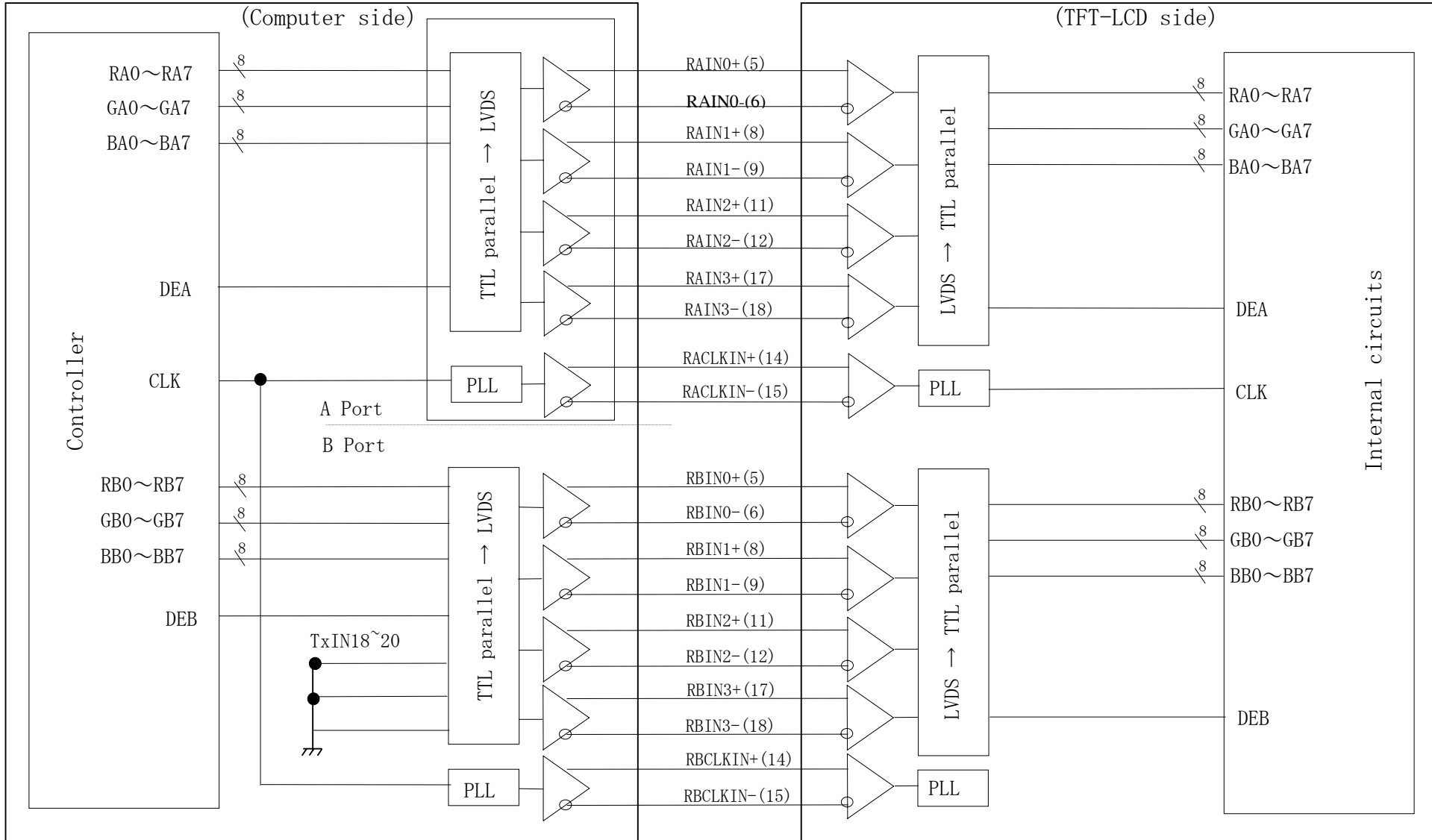

< SELLVDS= Low >

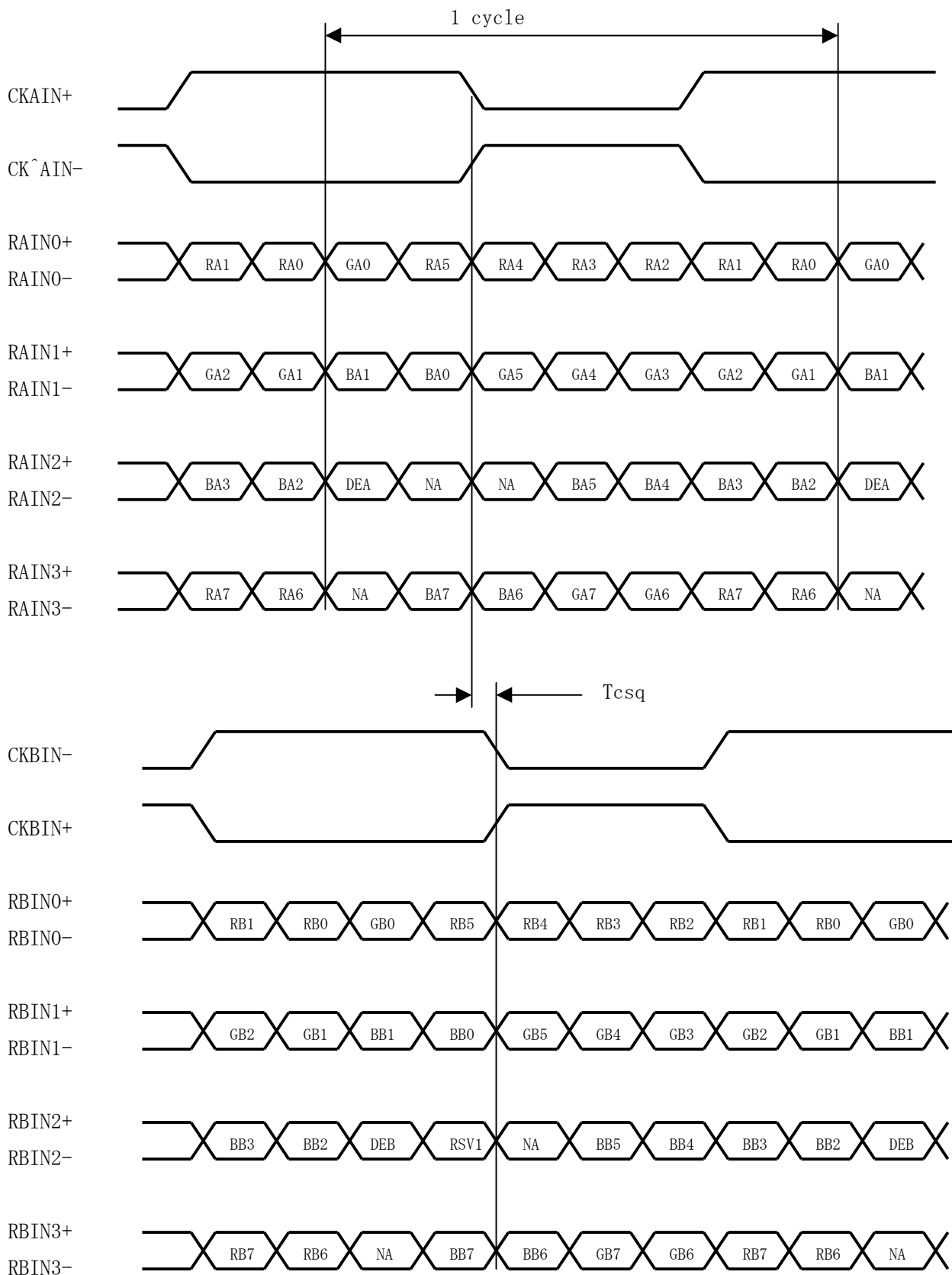

DE: Display Enable

RSV1: Reserve (Fixed GND)

NA: Not Available

< SELLVDS= High >

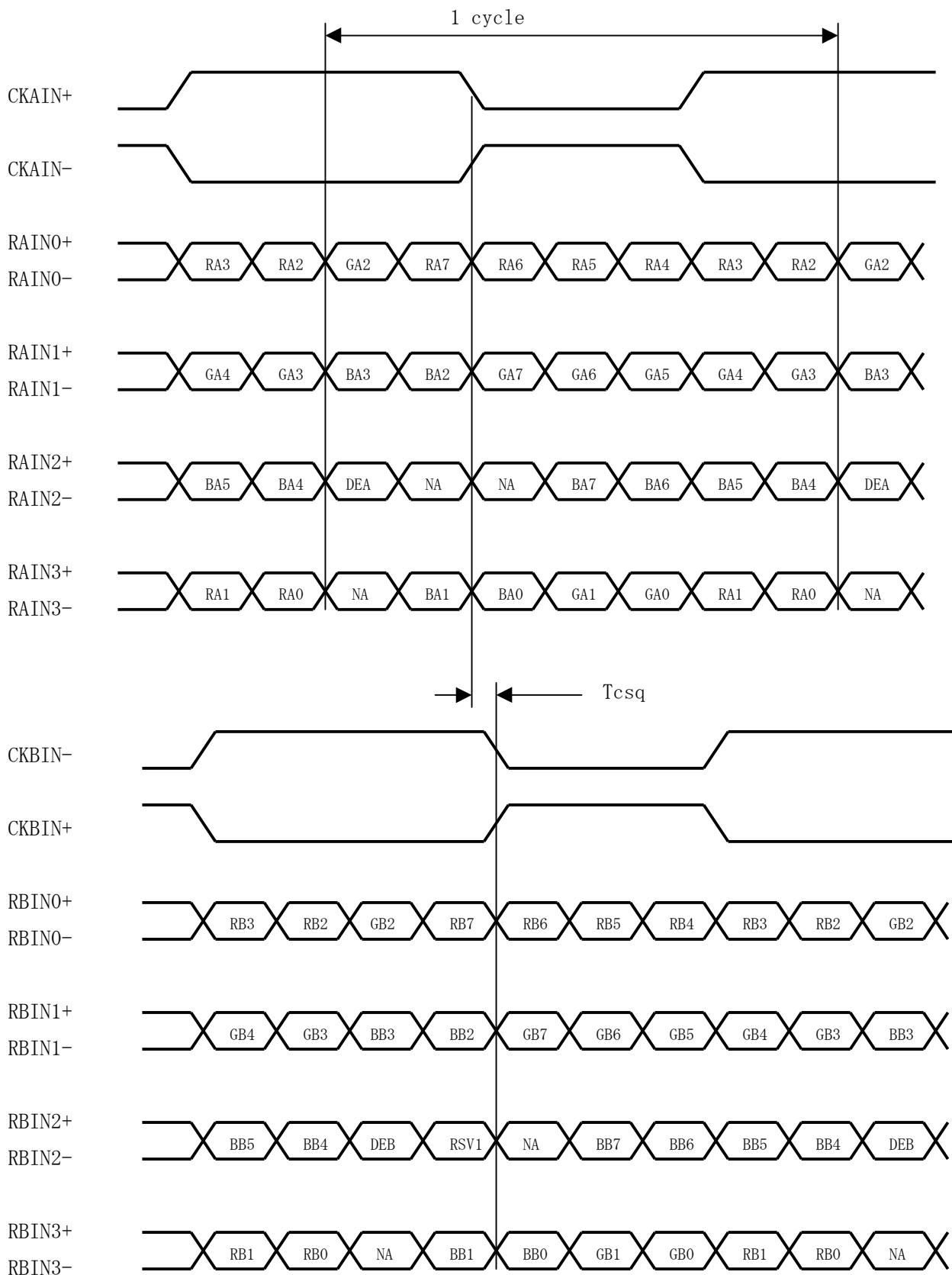

DE: Display Enable

RSV1: Reserve (Fixed GND)

NA: Not Available

4-2. Back light driving

CN 1, 2, 3 (Upside)

CN 4, 5, 6 (Downside)

The module-side connector : BHSR-02VS-01 (JST)

The user-side connector : SM02B-BHSS-1-TB (JST)

Pin no.	symbol	I/O	Function
1	V_{high}	I	Power supply (High voltage side)
2	V_{low}	I	Power supply (Low voltage side)

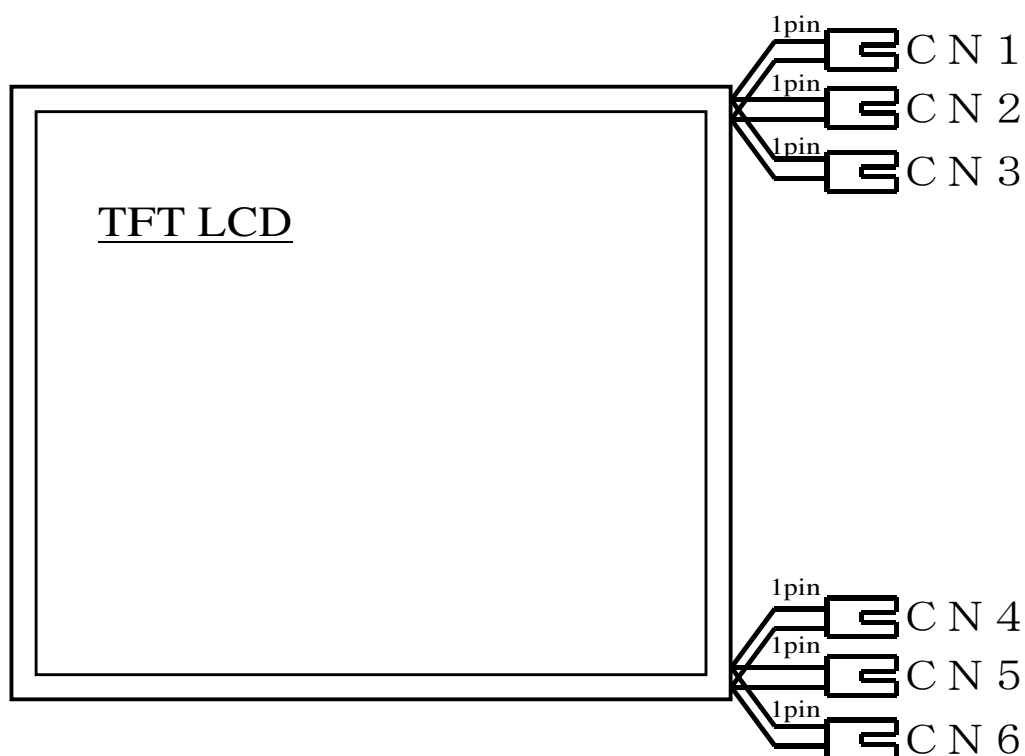

5. Absolute Maximum Ratings

Parameter	Symbol	Condition	Ratings	Unit	Remark
Input voltage	V_I	$T_a=25^{\circ}\text{C}$	$-0.3 \sim +3.6$	V	SELLVDS
+12.0V supply voltage	V_{cc}	$T_a=25^{\circ}\text{C}$	$0 \sim +14.0$	V	
Storage temperature	T_{stg}	—	$-25 \sim +60$	$^{\circ}\text{C}$	【Note1】
Operating temperature (Ambient)	T_{opa}	—	$0 \sim +50$	$^{\circ}\text{C}$	

【Note1】 Humidity : 95%RH Max. ($T_a \leq 40^{\circ}\text{C}$)

Maximum wet-bulb temperature at 39°C or less. ($T_a > 40^{\circ}\text{C}$)

No condensation.

6. Electrical Characteristics

6-1. TFT-LCD panel driving

Ta=25°C

Parameter		Symbol	Min.	Typ.	Max.	Unit	Remark
Vcc	Supply voltage	Vcc	+11.4	+12.0	+12.6	V	【Note1】
	Current dissipation	Icc	—	390	600	mA	【Note2】
Permissive input ripple voltage		V _{RF}	—	—	100	mVp-p	
Input voltage (Low)		V _{IL}	0	—	+0.6	V	SELLVDS
Input voltage (High)		V _{IH}	+2.7	—	+3.3	V	SELLVDS
Input current (Low)		I _{IL}	—	—	500	μA	SELLVDS V _I =GND
Input current (High)		I _{IH}	—	—	100	μA	SELLVDS V _I =Vcc
Output voltage (Low)		V _{OL}	—	—	0.4	V	BLON:I _{OL} =-1mA
Output voltage (High)		V _{OH}	2.4	—	—	V	BLON:I _{OH} =1mA

【Note1】

1) On-off sequences of Vcc and data

- 0 < t1 ≤ 60ms
- 0 < t2 ≤ 10ms
- 0 ≤ t3 ≤ 1s
- t4 ≥ 100ms

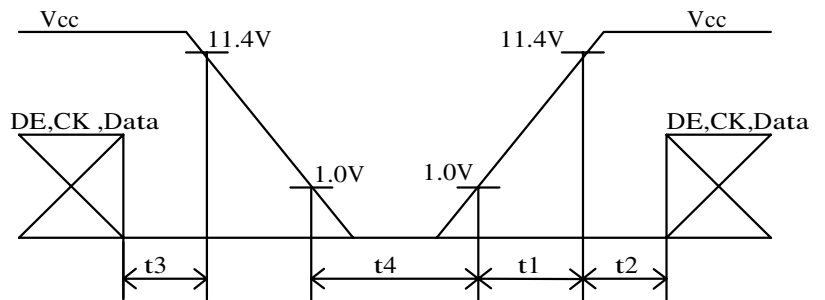

2) Dip conditions for supply voltage

V_{min}, V_{th} = 11.4V, 9.6V

- 1) V_{th} ≤ Vcc < V_{min}
t_d ≤ 20ms
- 2) Vcc < V_{th}

The LCD module shuts down.

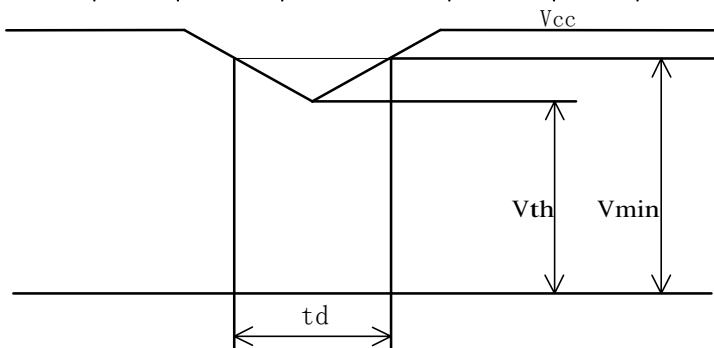

【Note2】 Typical current situation : 256-gray-bar pattern

Vcc=+12.0V

The explanation of each gray scale ,GS,
is described below section 8.

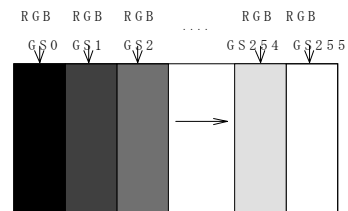

6-2. Back light driving

The back light system is an edge-lighting type with six CCFTs (Cold Cathode Fluorescent Tube).

The characteristics of the lamp are shown in the following table.

The value mentioned below is at the case of one CCFT.

CCFT Model Name : KTBE26MSTF - A424NE209 - Z - 3 (STANLEY. ELECTRIC. CO., LTD)

Parameter	Symbol	Min.	Typ.	Max.	Unit	Remark
Lamp current range	I_L	3.0	6.0	6.5	mArms	【Note1】
Lamp voltage	V_L	—	790	—	Vrms	$T_a=25^{\circ}C$
Lamp power consumption	P_L	—	4.7	—	W	【Note2】
Lamp frequency	F_L	30	60	70	KHz	【Note3】
Kick-off voltage	V_s	—	—	1,500	Vrms	$T_a=25^{\circ}C$ 【Note4】
		—	—	2,000	Vrms	$T_a=0^{\circ}C$ 【Note4】
Lamp life time	T_L	50,000	—	—	Hour	【Note5】

【Note1】 A lamp can be light in the range of lamp current shown above.

Maximum rating for current is measured by high frequency current measurement equipment connected to V_{LOW} at circuit showed below.

(Note : To keep enough kick-off voltage and necessary steady voltage for CCFT.)

Lamp frequency : 30~70kHz

Ambient temperature : 0~50°C

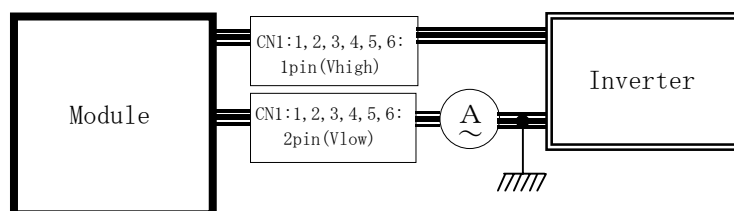

【Note2】 Referential data per one CCFT by calculation ($I_L \times V_L$).

The data doesn't include loss at inverter .

【Note3】 Lamp frequency of inverter may produce interference with horizontal synchronous frequency, and this may cause horizontal beat on the display. Therefore, adjust lamp frequency, and keep inverter as far as from module or use electronic shielding between inverter and module to avoid interference.

【Note4】 Kick-off voltage value is described as the index in the state of lamp only.

The kick-off voltage is estimated to be risen up as approx. +200V in the state of module only, and the further rise up can be seen according to the assembling status of user cabinet. Please set the kick-off voltage of inverter to avoid the lighting failures in the state of operation. Please design the inverter so that its open output voltage can be connected for more than 1 second to startup. Otherwise, the lamp may not be turned on. But, please set as 100ms when the ambient luminance around the lamp is more than 1lux.

【Note5】 Lamp life time is defined as the time when either ① or ② occurs in the continuous operation under the condition of $T_a=25^{\circ}C$ and $I_L=6.0$ mArms .

① Brightness becomes 50% of the original value under standard condition.

② Kick-off voltage at $T_a=0^{\circ}C$ exceeds maximum value,2000Vrms .

《Note》

The performance of the backlight, for example lifetime or brightness, is much influenced by the characteristics of the DC-AC inverter for the lamp. When you design or order the inverter, please make sure that a poor lighting caused by the mismatch of the backlight and the inverter (miss-lighting, flicker, etc.) never occurs. When you confirm it, the module should be operated in the same condition as it is installed in your instrument.

Use the lamp inverter power source incorporating such safeguard as overvoltage / overcurrent protective circuit or lamp voltage waveform detection circuit, which should have individual control of each lamp.

In case one circuit without such individual control is connected to more than two lamps, excessive current may flow into one lamp when the other one is not in operation.

Synchronize frequency and phase of two CCFT in the same connector.

Otherwise it may exceed rated voltage of connector.

7. Timing characteristics of input signals

7-1-1. Timing characteristics

	Parameter	Symbol	Min.	Typ.	Max.	Unit	Remark
Clock	Frequency	1/Tc	60.0	81.0	85.0	MHz	
	Skew	Tcsq	-4	0	4	ns	【Note1】
Data enable signal	Horizontal period	TH	830	1080	1600	clock	
			10.0	13.3	—	μs	
	Horizontal period (High)	THd	800	800	800	clock	
	Vertical period	TV	1205	1250	2000	line	【Note2】
			12.1	16.7	—	ms	
Vertical period (High)	TVd	1200	1200	1200	line		

【Note1】 Lvds (A port)– Lvds (B port) phase difference

【Note2】 In case of using the long vertical period, the deterioration of display quality, flicker etc. may occur.

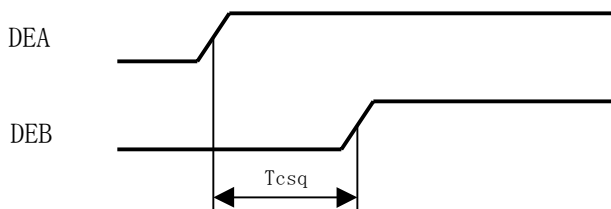
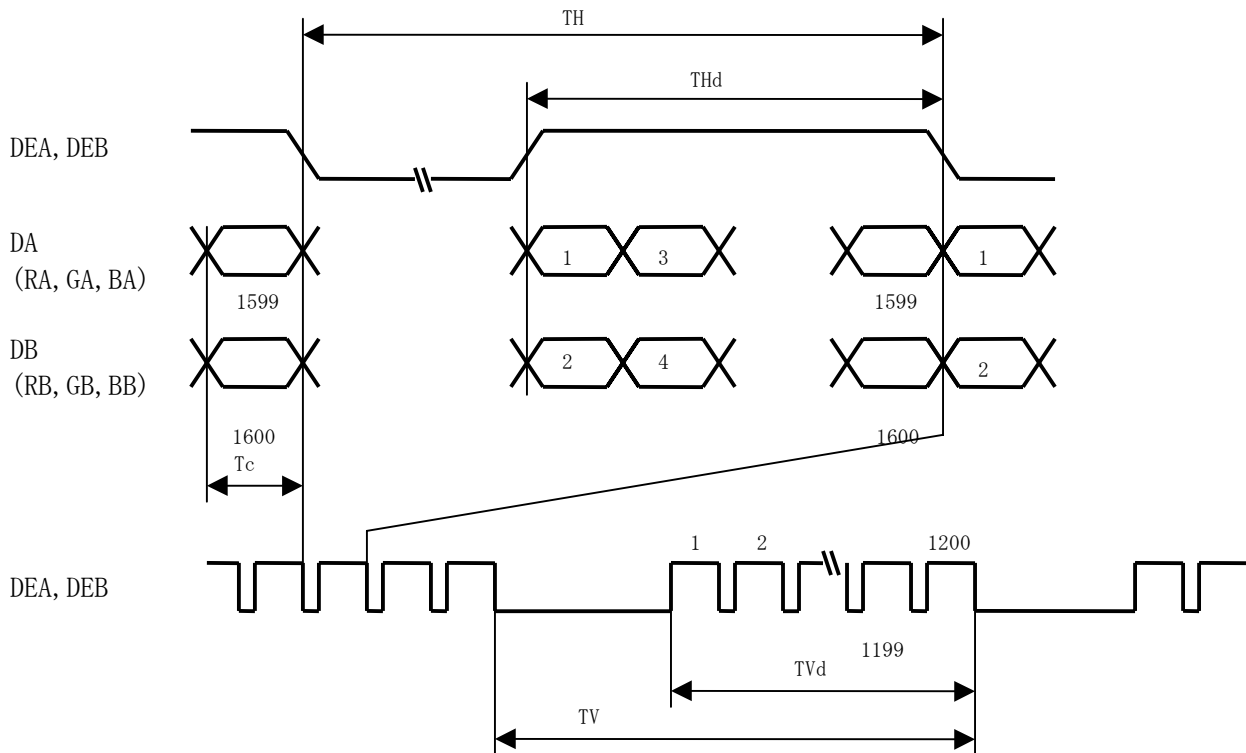

7-2 Input Data Signals and Display Position on the screen

Graphics and texts can be displayed on a $1600 \times 3 \times 1200$ dots panel with 16M colors by supplying 48 bit data signal (8bit/color [256 gray scales] $\times 3 \times 2$ pixels).

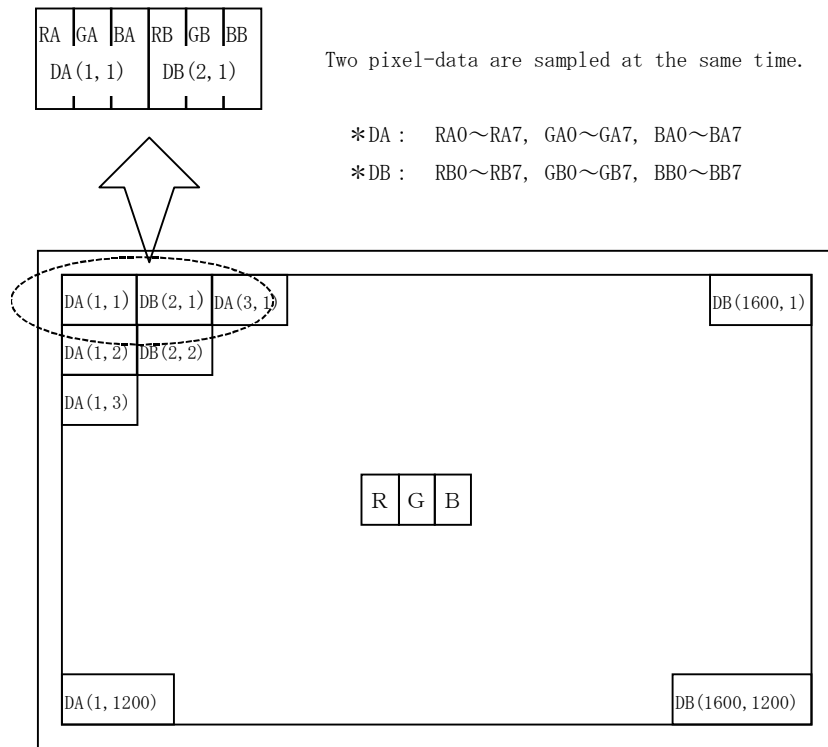

Display position of input data (H, V)

8. Input Signals, Basic Display Colors and Gray Scale of Each Color

Colors & Gray scale	Gray Scale	Data signal																											
		RA0 RA1 RA2 RA3 RA4 RA5 RA6 RA7	GA0 GA1 GA2 GA3 GA4 GA5 GA6 GA7	BA0 BA1 BA2 BA3 BA4 BA5 BA6 BA7																									
		RB0 RB1 RB2 RB3 RB4 RB5 RB6 RB7	GB0 GB1 GB2 GB3 GB4 GB5 GB6 GB7	BB0 BB1 BB2 BB3 BB4 BB5 BB6 BB7																									
Basic Color	Black	—	0 0 0 0 0 0 0 0	0 0 0 0 0 0 0 0	0 0 0 0 0 0 0 0																								
	Blue	—	0 0 0 0 0 0 0 0	0 0 0 0 0 0 0 0	1 1 1 1 1 1 1 1																								
	Green	—	0 0 0 0 0 0 0 0	1 1 1 1 1 1 1 1	0 0 0 0 0 0 0 0																								
	Cyan	—	0 0 0 0 0 0 0 0	1 1 1 1 1 1 1 1	1 1 1 1 1 1 1 1																								
	Red	—	1 1 1 1 1 1 1 1	0 0 0 0 0 0 0 0	0 0 0 0 0 0 0 0																								
	Magenta	—	1 1 1 1 1 1 1 1	0 0 0 0 0 0 0 0	1 1 1 1 1 1 1 1																								
	Yellow	—	1 1 1 1 1 1 1 1	1 1 1 1 1 1 1 1	0 0 0 0 0 0 0 0																								
	White	—	1 1 1 1 1 1 1 1	1 1 1 1 1 1 1 1	1 1 1 1 1 1 1 1																								
Gray Scale of Red	Black	GS0	0 0 0 0 0 0 0 0	0 0 0 0 0 0 0 0	0 0 0 0 0 0 0 0																								
	↑	GS1	1 0 0 0 0 0 0 0	0 0 0 0 0 0 0 0	0 0 0 0 0 0 0 0																								
	Darker	GS2	0 1 0 0 0 0 0 0	0 0 0 0 0 0 0 0	0 0 0 0 0 0 0 0																								
	↑	↓		↓	↓	↓																							
	↓	↓		↓	↓	↓																							
	Brighter	GS250	1 0 1 1 1 1 1 1	0 0 0 0 0 0 0 0	0 0 0 0 0 0 0 0																								
	↓	GS251	0 1 1 1 1 1 1 1	0 0 0 0 0 0 0 0	0 0 0 0 0 0 0 0																								
	Red	GS252	1 1 1 1 1 1 1 1	0 0 0 0 0 0 0 0	0 0 0 0 0 0 0 0																								
Gray Scale of Green	Black	GS0	0 0 0 0 0 0 0 0	0 0 0 0 0 0 0 0	0 0 0 0 0 0 0 0																								
	↑	GS1	0 0 0 0 0 0 0 0	1 0 0 0 0 0 0 0	0 0 0 0 0 0 0 0																								
	Darker	GS2	0 0 0 0 0 0 0 0	0 1 0 0 0 0 0 0	0 0 0 0 0 0 0 0																								
	↑	↓		↓	↓	↓																							
	↓	↓		↓	↓	↓																							
	Brighter	GS250	0 0 0 0 0 0 0 0	1 0 1 1 1 1 1 1	0 0 0 0 0 0 0 0																								
	↓	GS251	0 0 0 0 0 0 0 0	0 1 1 1 1 1 1 1	0 0 0 0 0 0 0 0																								
	Green	GS252	0 0 0 0 0 0 0 0	1 1 1 1 1 1 1 1	0 0 0 0 0 0 0 0																								
Gray Scale of Blue	Black	GS0	0 0 0 0 0 0 0 0	0 0 0 0 0 0 0 0	0 0 0 0 0 0 0 0																								
	↑	GS1	0 0 0 0 0 0 0 0	0 0 0 0 0 0 0 0	1 0 0 0 0 0 0 0																								
	Darker	GS2	0 0 0 0 0 0 0 0	0 0 0 0 0 0 0 0	0 1 0 0 0 0 0 0																								
	↑	↓		↓	↓	↓																							
	↓	↓		↓	↓	↓																							
	Brighter	GS250	0 0 0 0 0 0 0 0	0 0 0 0 0 0 0 0	1 0 1 1 1 1 1 1																								
	↓	GS251	0 0 0 0 0 0 0 0	0 0 0 0 0 0 0 0	0 1 1 1 1 1 1 1																								
	Blue	GS252	0 0 0 0 0 0 0 0	0 0 0 0 0 0 0 0	1 1 1 1 1 1 1 1																								

0 : Low level voltage, 1 : High level voltage.

Each basic color can be displayed in 256 gray scales from 8 bit data signals. According to the combination of total 48 bit data signals, the 16-million-color display can be achieved on the screen.

9. Optical Characteristics

Ta=25°C, Vcc =+12V

Parameter		Symbol	Condition	Min.	Typ.	Max.	Unit	Remark
Viewing Angle range	Vertical	$\theta 11$	$CR \geq 10$	70	85	—	Deg.	【Note1,4】
		$\theta 12$		70	85	—	Deg.	
	Horizontal	$\theta 21, \theta 22$		70	85	—	Deg.	
Contrast ratio		C R	$\theta = 0^\circ$	—	350	—		【Note2,4】
Response Time	Rise	τd		—	5	25	m s	【Note3,4】
	Decay	τr		—	20	50	m s	
Chromaticity of white		W_x		0.283	0.313	0.343	—	【Note4】
		W_y		0.299	0.329	0.359	—	
Chromaticity of red		R_x		0.608	0.638	0.668	—	
		R_y		0.309	0.339	0.369	—	
Chromaticity of green		G_x		0.250	0.280	0.310	—	
		G_y		0.570	0.600	0.630	—	
Chromaticity of blue		B_x		0.114	0.144	0.174	—	
		B_y		0.057	0.087	0.117	—	
Luminance of white		Y_L		180	220	—	cd/m ²	IL=6.0mA rms 【Note4】
White Uniformity		δw		—	—	1.25	—	【Note5】

※The measurement shall be executed 30 minutes after lighting at rating.

The optical characteristics shall be measured in a dark room or equivalent state with the method shown in Fig.2 below.

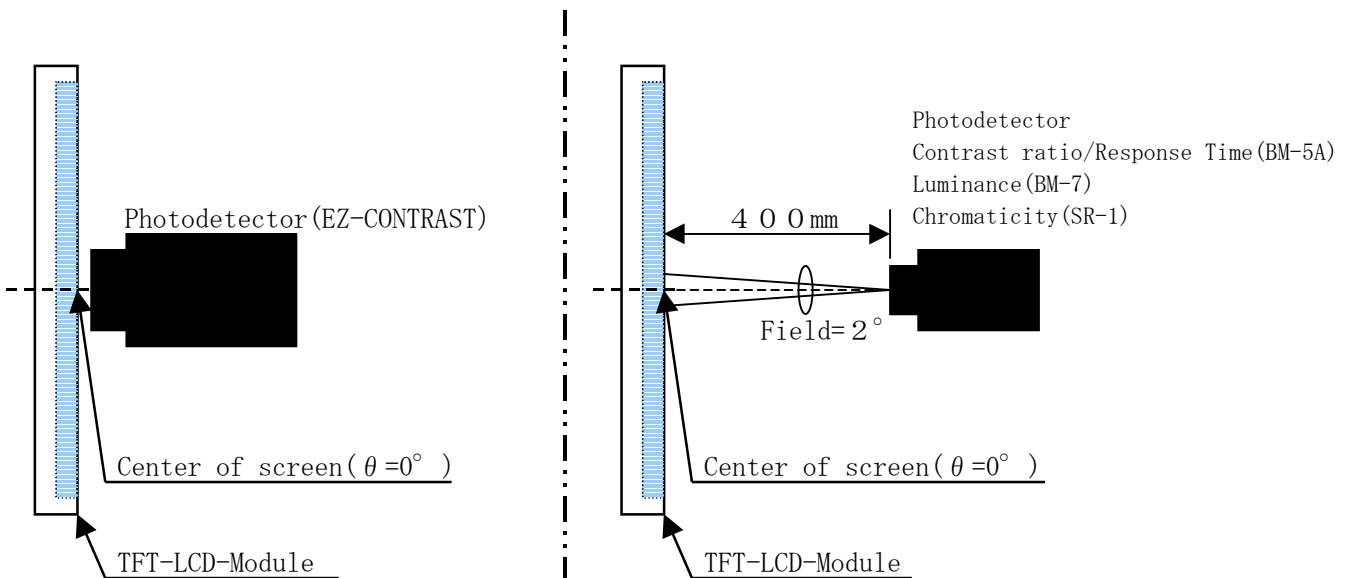
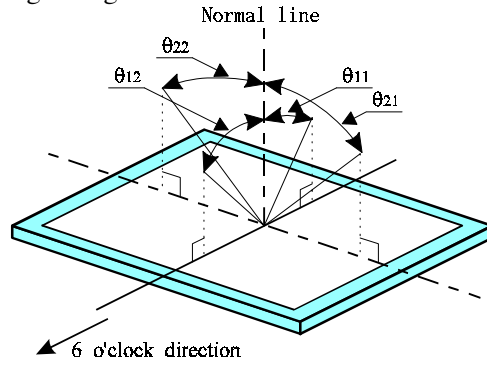

Fig2-1 Viewing angle measurement method

Fig2-2 Luminance/Contrast ratio/Response time/Chromaticity measurement method

Fig2 Optical characteristics measurement method

【Note1】 Definitions of viewing angle range:



【Note2】 Definition of contrast ratio:

The contrast ratio is defined as the following.

$$\text{Contrast Ratio (CR)} = \frac{\text{Luminance (brightness) with all pixels white}}{\text{Luminance (brightness) with all pixels black}}$$

【Note3】 Definition of response time:

The response time is defined as the following figure and shall be measured by switching the input signal for "black" and "white".

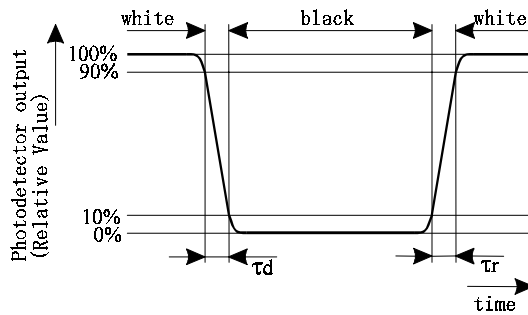

【Note4】 This shall be measured at center of the screen.

【Note5】 Definition of white uniformity:

White uniformity is defined as the following with five measurements (A~E).

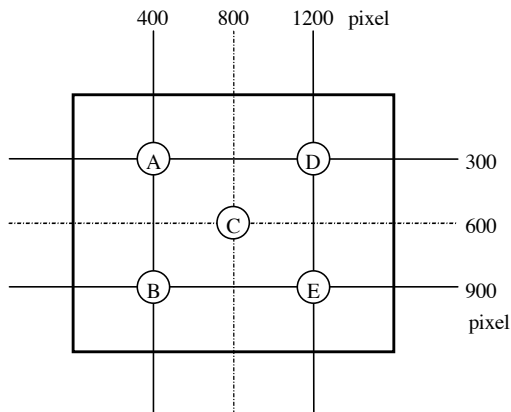

$$\delta_w = \frac{\text{Maximum Luminance of five points (brightness)}}{\text{Minimum Luminance of five points (brightness)}}$$

10. Handling Precautions

- a) Be sure to turn off the power supply when inserting or disconnecting the cable.
- b) Be sure to design the cabinet so that the module can be installed without any extra stress such as warp or twist.
- c) Since the front polarize is easily damaged, pay attention not to scratch it.
- d) Since long contact with water may cause discoloration or spots, wipe off water drop immediately.
- e) When the panel surface is soiled, wipe it with absorbent cotton or other soft cloth.
- f) Since the panel is made of glass, it may break or crack if dropped or bumped on hard surface. Handle with care.
- g) Since CMOS LSI is used in this module, take care of static electricity and take the human earth into consideration when handling.
- h) Make sure the mounting holes of the module are grounded sufficiently. Take electro-magnetic interference (EMI) into consideration.
- i) The module has some printed circuit boards (PCBs) on the back side. Take care to keep them from any stress or pressure when handling or installing the module; otherwise some of electronic parts on the PCBs may be damaged.
- j) Observe all other precautionary requirements in handling components.
- k) When some pressure is added onto the module from rear side constantly, it causes display non-uniformity issue , functional defect, etc. So, please avoid such design.
- l) If the stress is applied onto the panel under operating conditions, display defects such as black dots may occur. So, do not press the display with fingers.

To recover this defect, turn off the power supply and restart after several seconds.

11. Packing form

- a) Piling number of cartons : maximum 8 cartons
- b) Packing quantity in one carton : 2 module
- c) Carton size : 592mm(W) × 486mm(H) × 215(D)
- d) Total mass of one carton filled with full modules : 10.5kg
- e) Packing form is shown in Fig.3

12. Reliability test items

No.	Test item	Conditions
1	High temperature storage test	Ta=60°C 240h
2	Low temperature storage test	Ta=-25°C 240h
3	High temperature & high humidity operation test	Ta=40°C ; 95%RH 240h (No condensation)
4	High temperature operation test	Ta=50°C 240h (The panel temp. must be less than 60°C)
5	Low temperature operation test	Ta=0°C 240H
6	Vibration test (non- operating)	Frequency : 10~57Hz/Vibration width (one side) : 0.075mm : 58~500Hz/Gravity : 9.8m/s ² Sweep time : 11 minutes Test period : 3 hours (1 hour for each direction of X,Y,Z)
7	Shock test (non- operating)	Max. gravity : 490m/s ² Pulse width : 11ms, sine wave Direction : ±X, ±Y, ±Z, once for each direction.

【Result Evaluation Criteria】

Under the display quality test conditions with normal operation state, these shall be no change which may affect practical display function.

13. Others

1) Lot No. and indication Bar Code Label:

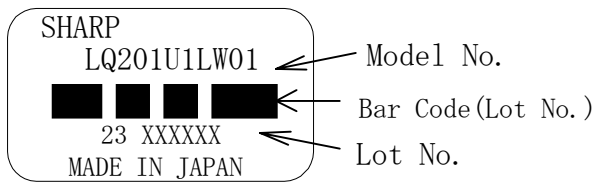

How to express Lot No.

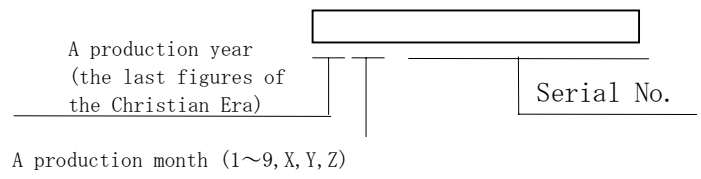

2) Packing Label

- ① Model No. (LQ201U1LW01) ② Lot No. (Date) ③ Quantity

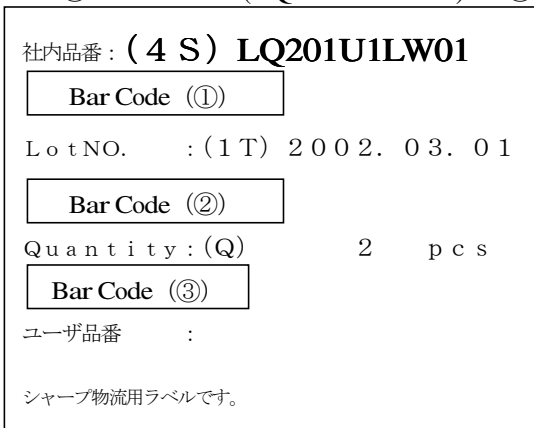

3) Adjusting volume have been set optimally before shipment, so do not change any adjusted value.

If adjusted value is changed, the specification may not be satisfied.

- 4) Disassembling the module can cause permanent damage and should be strictly avoided.
- 5) Please be careful since image retention may occur when a fixed pattern is displayed for a long time.
- 6) The chemical compound that causes the destruction of ozone layer is not being used.
- 7) Warning of mercury and material information of LPG(Light Pipe Guide) are labeled on the back of the module.

MATERIAL INFORMATION
>PLASTIC LIGHT GUIDE:PMMA<

COLD CATHODE FLUORESCENT LAMP IN LCD PANEL
CONTAINS A SMALL AMOUNT OF MERCURY, PLEASE FOLLOW
LOCAL ORDINANCES OR REGULATION FOR DISPOSAL
当該液晶ディスプレイパネルは蛍光管が組み込まれていますので、地方自治体の条例、または、規則に従って廃棄ください。

8) When any question or issue occurs, it shall be solved by mutual discussion.

14. Carton storage condition

Temperature	0°C to 40°C
Humidity	95%RH or less
Reference condition :	20°C to 35°C , 85%RH or less (summer) : 5°C to 15°C , 85%RH or less (winter) • the total storage time (40°C,95%RH) : 240H or less
Sunlight	Be sure to shelter a product from the direct sunlight.
Atmosphere	Harmful gas, such as acid and alkali which bites electronic components and/or wires, must not be detected.
Notes	Be sure to put cartons on palette or base, don't put it on floor, and store them with removing from wall. Please take care of ventilation in storehouse and around cartons, and control changing temperature is within limits of natural environment.
Storage period	1 year

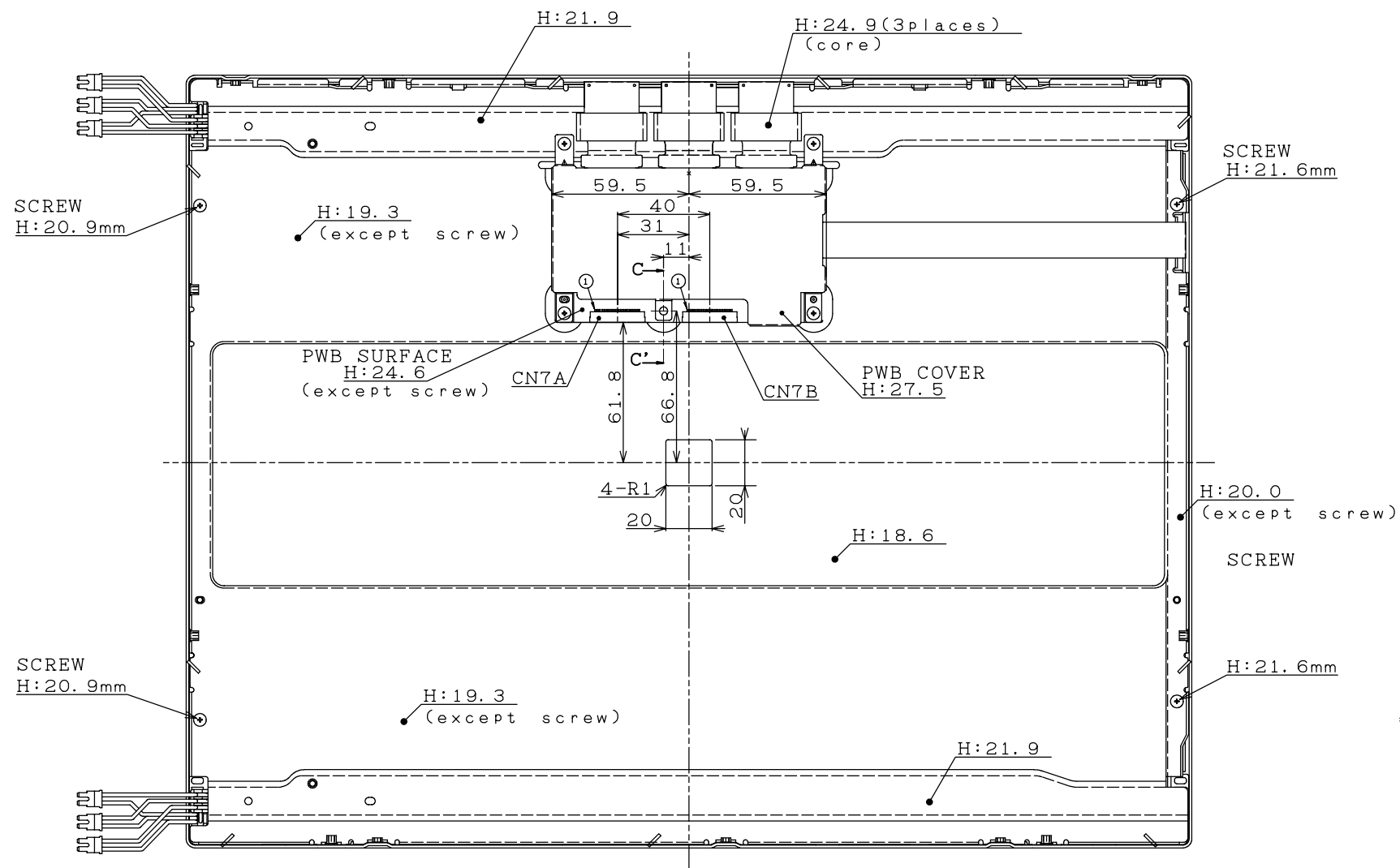

I/F CONNECTOR

CN7A:DF19G-20P-1H(HIROSE)
CN7B:DF19G-20P-1H(HIROSE)

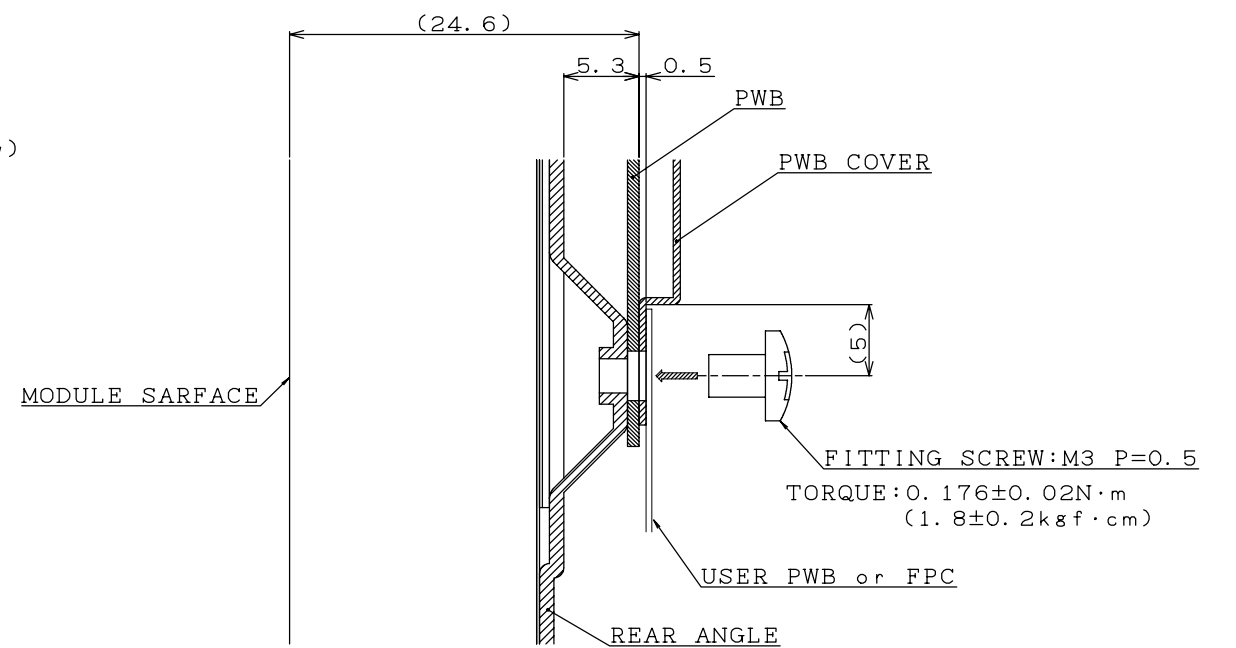

SECTION C-C'

20.1" UXGA TFT MODULE OUTLINE DIMENSIONS

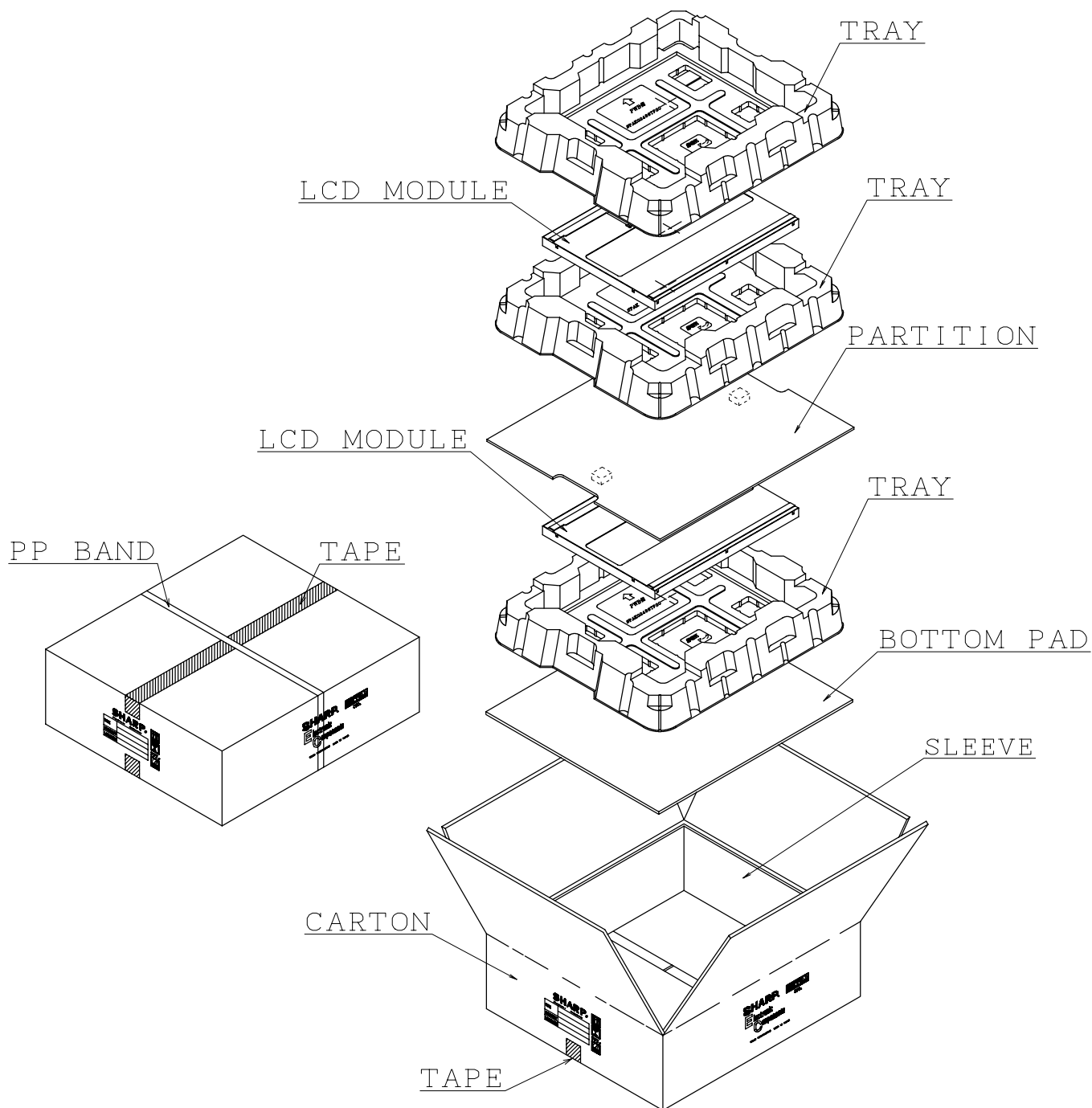

<Packing Form>

SPECIFICATIONS ARE SUBJECT TO CHANGE WITHOUT NOTICE.

Suggested applications (if any) are for standard use; See Important Restrictions for limitations on special applications. See Limited Warranty for SHARP's product warranty. The Limited Warranty is in lieu, and exclusive of, all other warranties, express or implied. ALL EXPRESS AND IMPLIED WARRANTIES, INCLUDING THE WARRANTIES OF MERCHANTABILITY, FITNESS FOR USE AND FITNESS FOR A PARTICULAR PURPOSE, ARE SPECIFICALLY EXCLUDED. In no event will SHARP be liable, or in any way responsible, for any incidental or consequential economic or property damage.

SHARP®

NORTH AMERICA

SHARP Microelectronics of the Americas
5700 NW Pacific Rim Blvd.
Camas, WA 98607, U.S.A.
Phone: (1) 360-834-2500
Fax: (1) 360-834-8903
Fast Info: (1) 800-833-9437
www.sharpsma.com

EUROPE

SHARP Microelectronics Europe
Division of Sharp Electronics (Europe) GmbH
Sonninstrasse 3
20097 Hamburg, Germany
Phone: (49) 40-2376-2286
Fax: (49) 40-2376-2232
www.sharpsme.com

JAPAN

SHARP Corporation
Electronic Components & Devices
22-22 Nagaike-cho, Abeno-Ku
Osaka 545-8522, Japan
Phone: (81) 6-6621-1221
Fax: (81) 6117-725300/6117-725301
www.sharp-world.com

TAIWAN

SHARP Electronic Components
(Taiwan) Corporation
8F-A, No. 16, Sec. 4, Nanking E. Rd.
Taipei, Taiwan, Republic of China
Phone: (886) 2-2577-7341
Fax: (886) 2-2577-7326/2-2577-7328

SINGAPORE

SHARP Electronics (Singapore) PTE., Ltd.
438A, Alexandra Road, #05-01/02
Alexandra Technopark,
Singapore 119967
Phone: (65) 271-3566
Fax: (65) 271-3855

KOREA

SHARP Electronic Components
(Korea) Corporation
RM 501 Geosung B/D, 541
Dohwa-dong, Mapo-ku
Seoul 121-701, Korea
Phone: (82) 2-711-5813 ~ 8
Fax: (82) 2-711-5819

CHINA

SHARP Microelectronics of China
(Shanghai) Co., Ltd.
28 Xin Jin Qiao Road King Tower 16F
Pudong Shanghai, 201206 P.R. China
Phone: (86) 21-5854-7710/21-5834-6056
Fax: (86) 21-5854-4340/21-5834-6057

Head Office:

No. 360, Bashen Road,
Xin Development Bldg. 22
Waigaoqiao Free Trade Zone Shanghai
200131 P.R. China
Email: smc@china.global.sharp.co.jp

HONG KONG

SHARP-ROXY (Hong Kong) Ltd.
3rd Business Division,
17/F, Admiralty Centre, Tower 1
18 Harcourt Road, Hong Kong
Phone: (852) 28229311
Fax: (852) 28660779
www.sharp.com.hk

Shenzhen Representative Office:

Room 13B1, Tower C,
Electronics Science & Technology Building
Shen Nan Zhong Road
Shenzhen, P.R. China
Phone: (86) 755-3273731
Fax: (86) 755-3273735