



MODEL NO. : TM020HDH01

ISSUED DATE: 2010-01-17



VERSION : Ver 1.1

- Preliminary Specification
- Final Product Specification

Customer : _____

Approved by	Notes

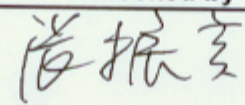
SHANGHAI TIANMA Confirmed :

Prepared by	Checked by	Approved by
 2010-01-17	 2010-01-17	

This technical specification is subjected to change without notice

The information contained herein is the exclusive property of SHANGHAI TIANMA MICRO-ELECTRONICS Corporation, and shall not be distributed, reproduced, or disclosed in whole or in part without prior written permission of SHANGHAI TIANMA MICRO-ELECTRONICS Corporation.



Table of Contents

Coversheet.....	1
Table of Contents	2
Record of Revision.....	3
1 General Specifications	4
2 Input/Output Terminals	5
3 Absolute Maximum Ratings	7
4 Electrical Characteristics.....	7
5 Timing Chart.....	10
6 Optical Characteristics	16
7 Environmental / Reliability Tests.....	19
8 Mechanical Drawing	20
9 Packing Drawing	21
10 Precautions for Use of LCD Modules.....	22



1 General Specifications

	Feature	Spec
Display Spec.	Size	2.0 inch
	Resolution	240(RGB) x 320
	Interface	CPU 8/16 bits
	Color Depth	65K/262K
	Technology Type	a-Si
	Pixel Pitch (mm)	0.126X0.126
	Pixel Configuration	R.G.B. Vertical Stripe
	Display Mode	TM with Normally White
	Surface Treatment(Up Polarizer)	Clear Type(3H)
	Viewing Direction	9 o'clock
	Gray Scale Inversion Direction	3 o'clock
Mechanical Characteristics	LCM (W x H x D) (mm)	38.03 x 51.65 x 2.35
	Active Area(mm)	30.24 x 40.32
	With /Without TSP	Without TSP
	Weight (g)	TBD
	LED Numbers	3 LEDs
Electronic	Driver IC	ILI9335

Note 1: Viewing direction for best image quality is different from TFT definition, there is a 180 degree shift.

Note 2: Requirements on Environmental Protection: RoHS

Note 3: LCM weight tolerance : +/- 5%

The information contained herein is the exclusive property of SHANGHAI TIANMA MICRO-ELECTRONICS Corporation, and shall not be distributed, reproduced, or disclosed in whole or in part without prior written permission of SHANGHAI TIANMA MICRO-ELECTRONICS Corporation.



2 Input/Output Terminals

2.1 TFT LCD Panel

No	Symbol	I/O	Description	Remark
1	DB15	I	Data Bus	Note 1
2	DB14	I	Data Bus	
3	DB13	I	Data Bus	
4	DB12	I	Data Bus	
5	DB11	I	Data Bus	
6	DB10	I	Data Bus	
7	DB09	I	Data Bus	
8	DB08	I	Data Bus	
9	GND	P	Ground	Note 1
10	DB07	I	Data Bus	
11	DB06	I	Data Bus	
12	DB05	I	Data Bus	
13	DB04	I	Data Bus	
14	DB03	I	Data Bus	
15	DB02	I	Data Bus	
16	DB01	I	Data Bus	
17	DB00	I	Data Bus	
18	IOVCC	P	Power Supply of I/O Interface	
19	VCC	P	Power Supply of Analog Circuit	
20	/RD	I	Read Signal	
21	/WR	I	Write Signal	
22	RS	I	Register Select	
23	/CS	I	Chip Select	
24	/RESET	I	Reset Signal	
25	IM0	I	Mode Select	Note2
26	GND	P	Ground	
27	LED-A	P	LED Anode	
28	LED-K1	P	LED Cathode	

The information contained herein is the exclusive property of SHANGHAI TIANMA MICRO-ELECTRONICS Corporation, and shall not be distributed, reproduced, or disclosed in whole or in part without prior written permission of SHANGHAI TIANMA MICRO-ELECTRONICS Corporation.



29	LED-K2	P	LED Cathode	
30	LED-K3	P	LED Cathode	Note 1
31	Y+	NC	No Connection	
32	Y-	NC	No Connection	
33	X+	NC	No Connection	
34	X-	NC	No Connection	
35	NC	NC	No Connection	
36	NC	NC	No Connection	

Note 1: I/O definition:

I----Input O---Output P----Power (Ground) NC---No Connection

Note2: 8/16 bit selection pin

IM0	Interface	DB pin
1	i80-parallel 8bit interface	DB15~08
0	i80-parallel 16bit interface	DB15~00



3 Absolute Maximum Ratings

3.1 Driving TFT LCD Panel

Ta = 25°C

Item	Symbol	Min	Max	Unit	Remark
Logic Supply Voltage	IOVCC	-0.3	4.6	V	
Analog Supply Voltage	VCC	-0.3	4.6	V	
Input Voltage	/CS,/RD,/WR,RS, IM0, /RESET,DB00~15	-0.3	IOVCC+0.3	V	
Back Light Forward Current	I _{LED}		25	mA	For each LED
Operating Temperature	T _{OPR}	-20	70	°C	
Storage Temperature	T _{STG}	-30	80	°C	

4 Electrical Characteristics

4.1 Driving TFT LCD Panel

GND=0V, Ta=25°C

Item	Symbol	Min	Typ	Max	Unit	Remark
Logic Supply Voltage	IOVCC	1.6	1.8	3.3	V	
Analog Supply Voltage	VCC	2.5	2.8	3.3	V	
Input Signal Voltage	Low Level	V _{IL}	0	0.2xIOVCC	V	/CS,/RD,/WR,RS, /RESET, IM0,DB00~DB15
	High Level	V _{IH}	0.8xIOVCC	IOVCC	V	
Output Signal Voltage	Low Level	V _{OL}	0	0.2xIOVCC	V	
	High Level	V _{OH}	0.8xIOVCC	IOVCC	V	
(Panel+LSI) Power Consumption	Black Mode (60Hz)	-	TBD	-	mW	
	Sleeping Mode	-	TBD	-	mW	
	Standby Mode	-	TBD	-	uW	

The information contained herein is the exclusive property of SHANGHAI TIANMA MICRO-ELECTRONICS Corporation, and shall not be distributed, reproduced, or disclosed in whole or in part without prior written permission of SHANGHAI TIANMA MICRO-ELECTRONICS Corporation.



4.2 Driving Backlight

Ta=25°C

Item	Symbol	Min	Typ	Max	Unit	Remark
Forward Current	I_F	-	15	-	mA	3 LEDs (in parallel)
Forward Voltage	V_F	-	3.2	-	V	
Backlight Power Consumption	W_{BL}	-	144	-	mW	
Operating Life Time	-	10000	20000	-	Hrs	

Note1: Figure below shows the connection of backlight LED.

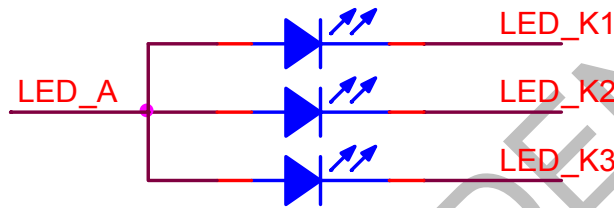

Note 2: One LED : $I_F = 15 \text{ mA}$, $V_F = 3.2 \text{ V}$

Note 3: I_F is defined for one channel LED.

Optical performance should be evaluated at $T_a = 25^\circ\text{C}$ only.

If LED is driven by high current, high ambient temperature & humidity condition. The life time of LED will be reduced.

Operating life means brightness goes down to 50% initial brightness. Typical operating life time is estimated data.



4.3 Block Diagram

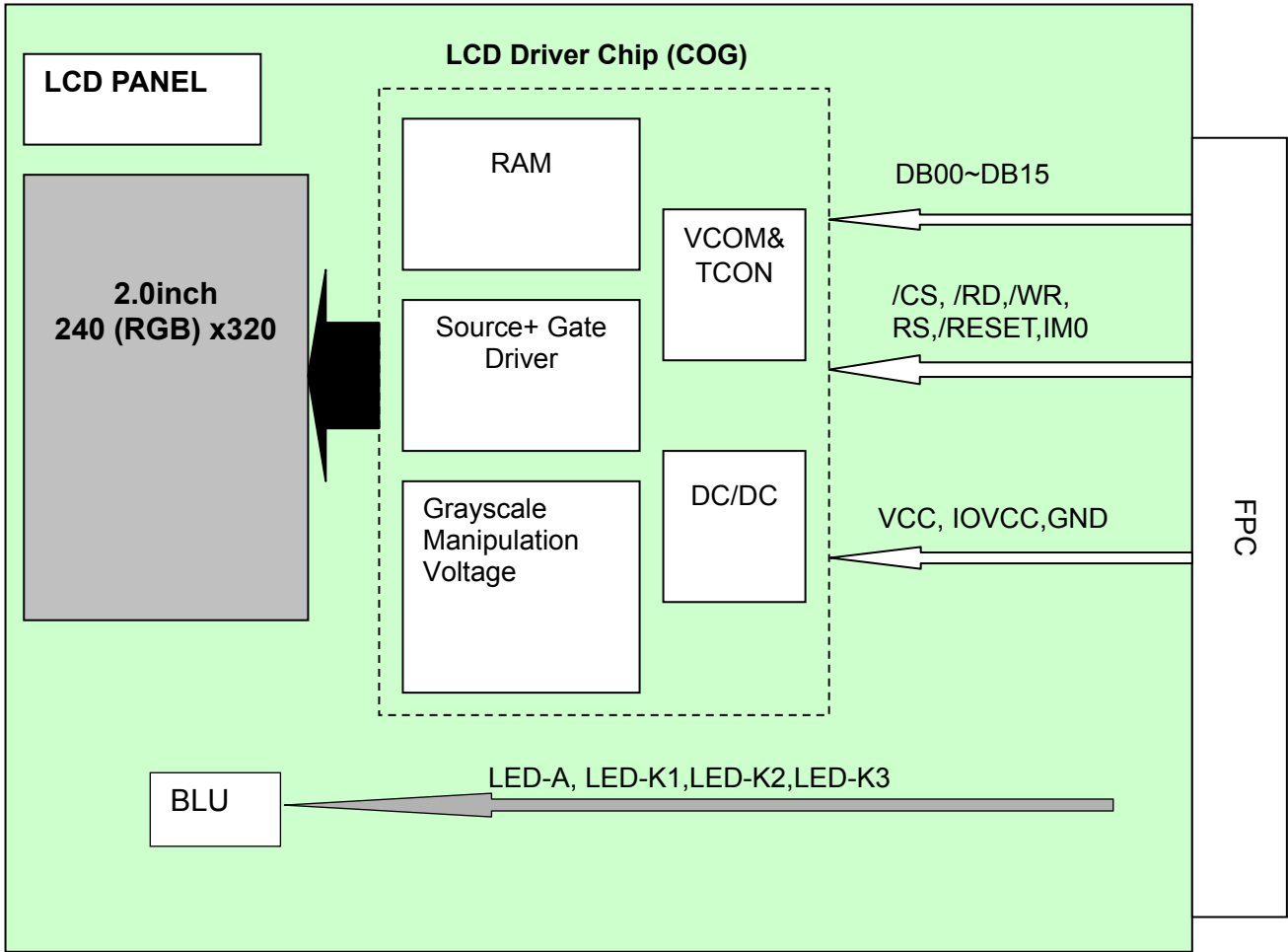

TIANMA



5 Timing Chart

5.1 I80 System Timing Parameter

Normal Write Mode

Item	Symbol	Unit	Min	Typ	Max	Test Condition
Bus cycle time	Write	t_{CYCW}	ns	(75)	-	-
	Read	t_{CYCR}	ns	300	-	-
Write low-level pulse width	PW_{LW}	ns	(40)	-	500	
Write high-level pulse width	PW_{HW}	ns	(30)	-	-	
Read low-level pulse width	PW_{LR}	ns	150	-	-	
Read high-level pulse width	PW_{HR}	ns	150	-	-	
Write / Read rise / fall time	t_{WRr} / t_{WRf}	ns	-	-	25	
Setup time	Write(RS to /CS, /WR)	t_{AS}	ns	10	-	-
	Read(RS to /CS, /RD)			5	-	-
Address hold time	t_{AH}	ns	5	-	-	
Write data set up time	t_{DSW}	ns	10	-	-	
Write data hold time	t_H	ns	15	-	-	
Read data delay time	t_{DDR}	ns	-	-	100	
Read data hold time	t_{DHR}	ns	5	-	-	

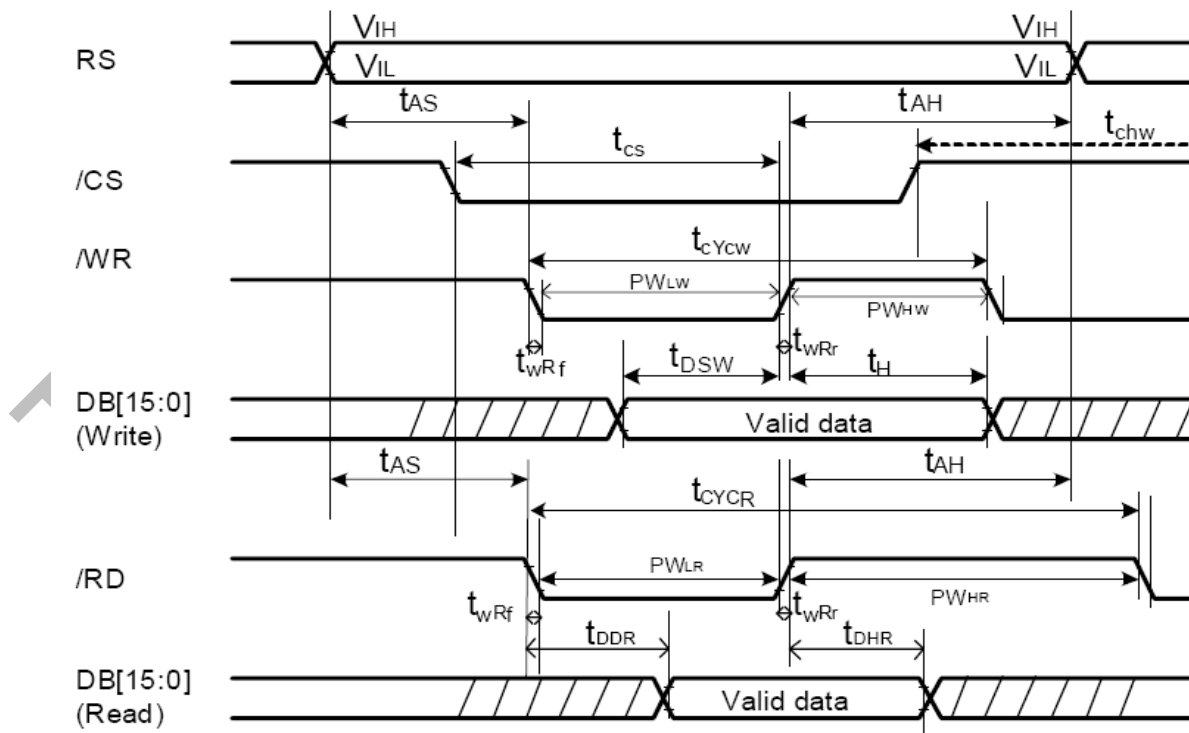

The information contained herein is the exclusive property of SHANGHAI TIANMA MICRO-ELECTRONICS Corporation, and shall not be distributed, reproduced, or disclosed in whole or in part without prior written permission of SHANGHAI TIANMA MICRO-ELECTRONICS Corporation.



5.2 Register Write /Read Timing In I80 8/16bit System

5.2.1 i80 16-bit System Bus Interface Timing

a. Write to register

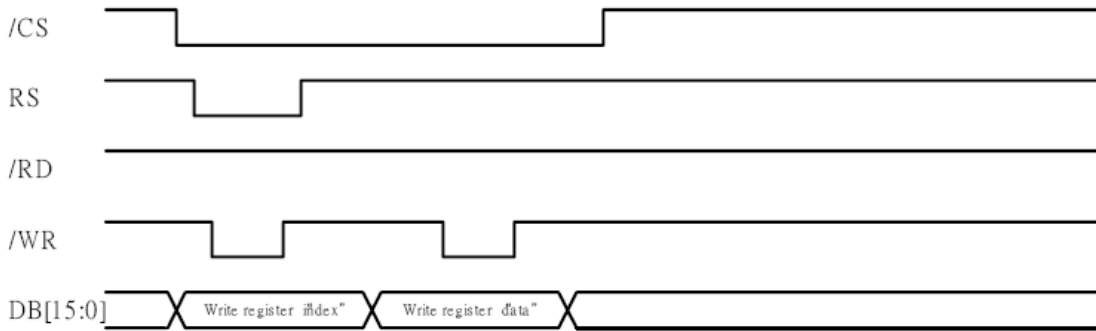

b. Read from register

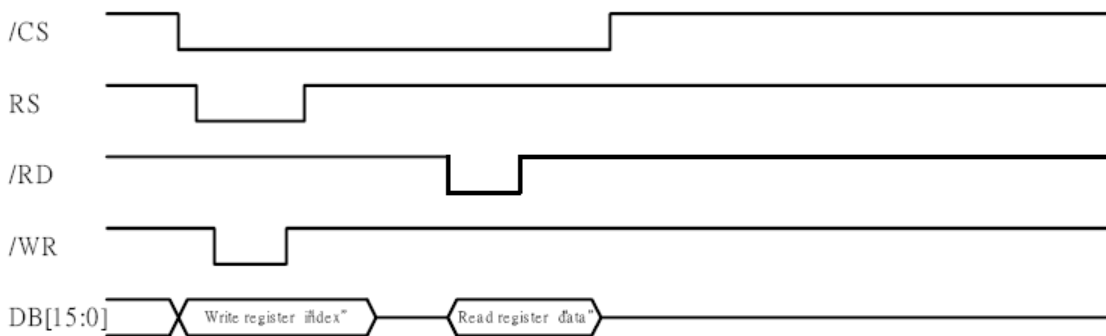

5.2.2 i80 8-bit System Bus Interface Timing

a. Write to register

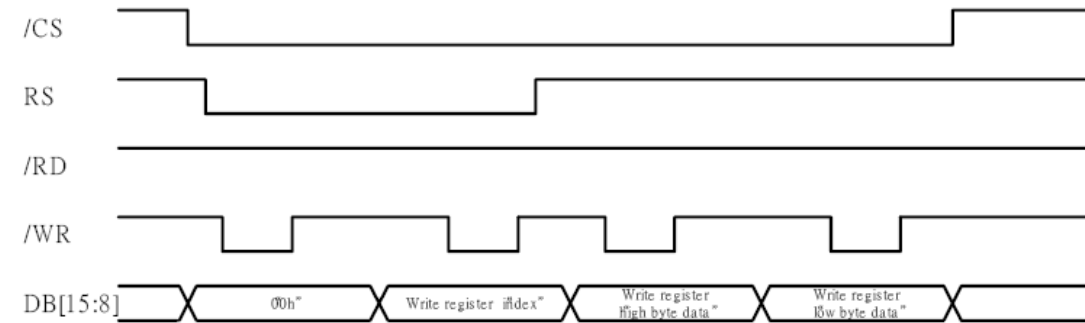

b. Read from register

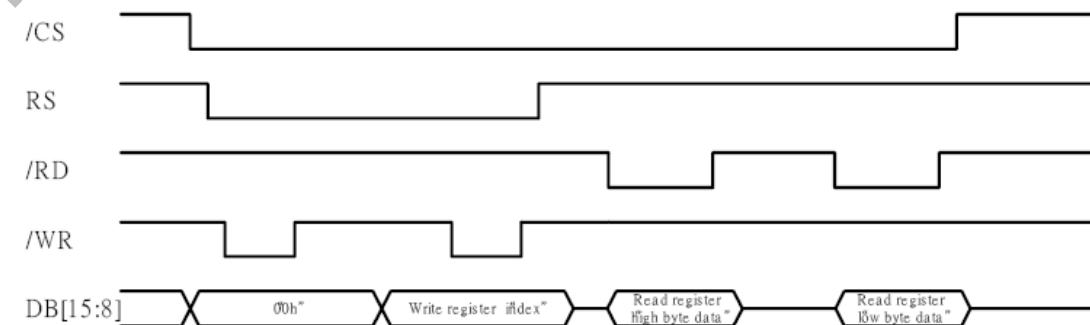

The information contained herein is the exclusive property of SHANGHAI TIANMA MICRO-ELECTRONICS Corporation, and shall not be distributed, reproduced, or disclosed in whole or in part without prior written permission of SHANGHAI TIANMA MICRO-ELECTRONICS Corporation.



5.3 GRAM Write Timing In i80 8/16bit System

5.3.1 i80 16-bit System Bus Interface Timing

a. Write to GRAM

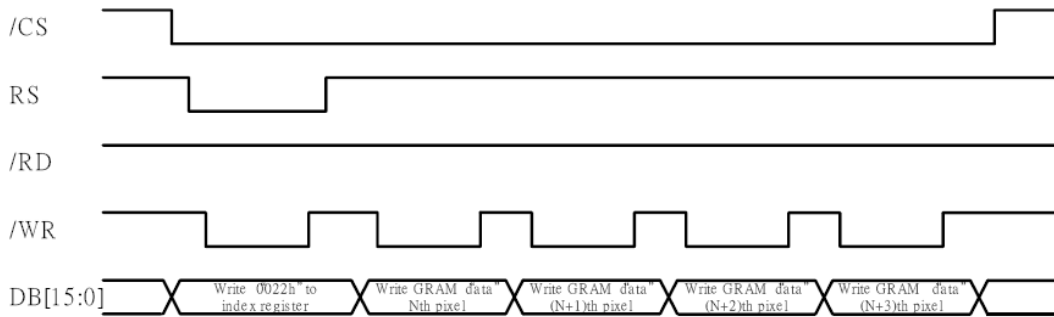

b. Read from GRAM

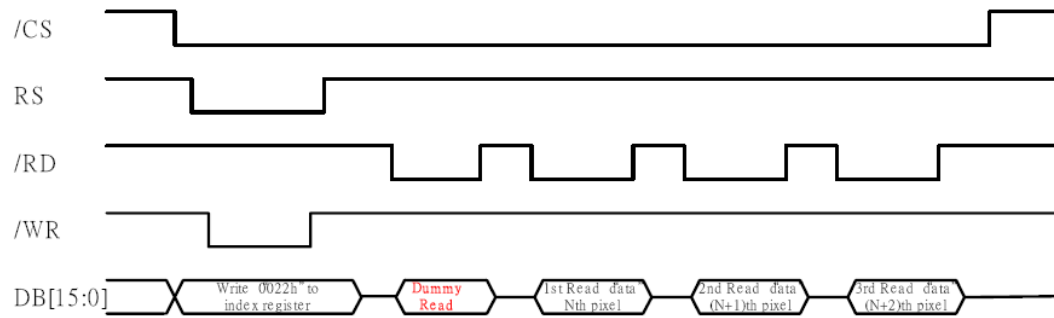

5.3.2 i80 8-bit System Bus Interface Timing

a. Write to GRAM

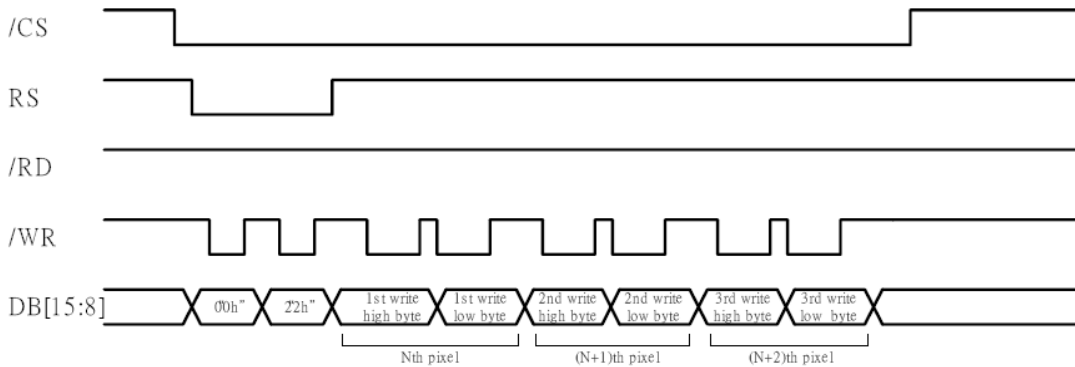

b. Read from GRAM

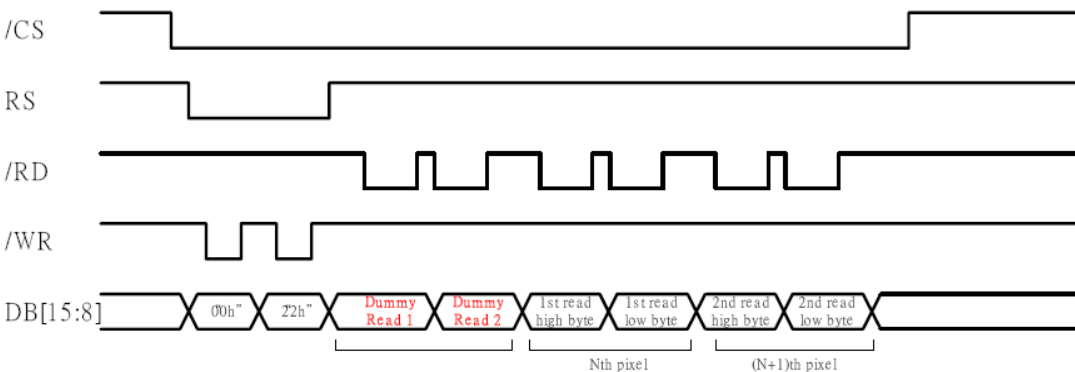

The information contained herein is the exclusive property of SHANGHAI TIANMA MICRO-ELECTRONICS Corporation, and shall not be distributed, reproduced, or disclosed in whole or in part without prior written permission of SHANGHAI TIANMA MICRO-ELECTRONICS Corporation.



5.4 Reset Timing Characteristics

Ta=25°C

Item	Symbol	Unit	Min	Typ	Max
Reset low-level width	t_{RES_L}	ms	1	-	-
Reset rise time	t_{rRES}	μ s	-	-	10
Reset high-level width	t_{rRES-H}	ms	50		

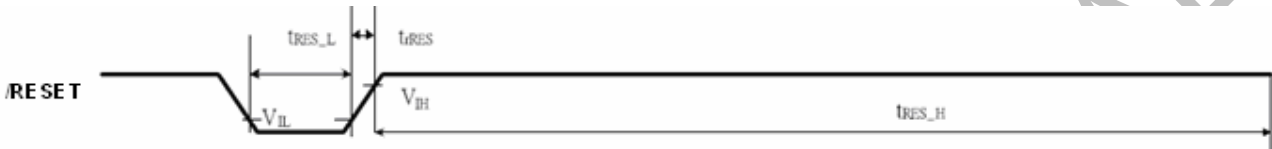

The information contained herein is the exclusive property of SHANGHAI TIANMA MICRO-ELECTRONICS Corporation, and shall not be distributed, reproduced, or disclosed in whole or in part without prior written permission of SHANGHAI TIANMA MICRO-ELECTRONICS Corporation.



6 Power On/Off Sequence

6.1 Power on Sequence

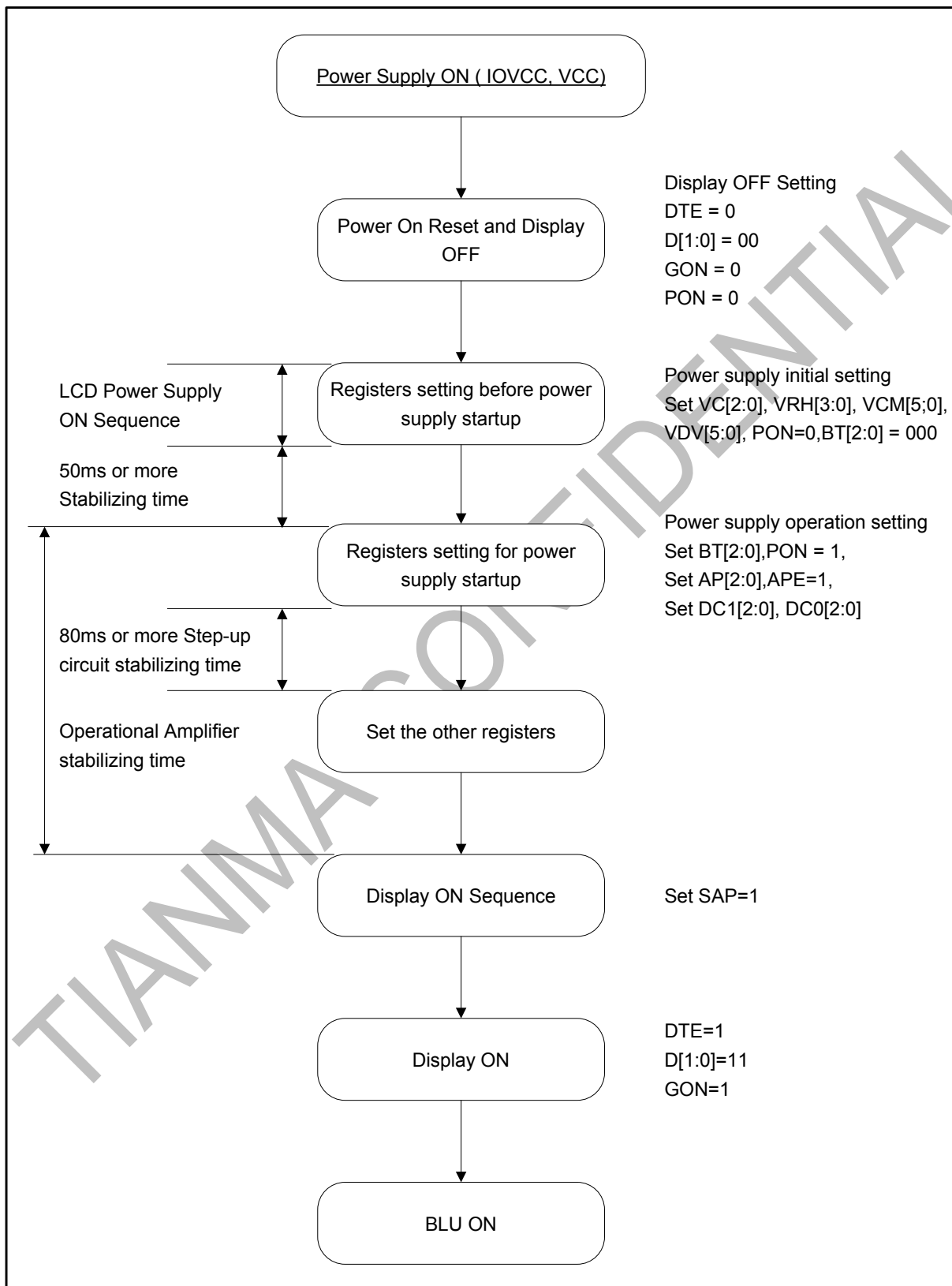

The information contained herein is the exclusive property of SHANGHAI TIANMA MICRO-ELECTRONICS Corporation, and shall not be distributed, reproduced, or disclosed in whole or in part without prior written permission of SHANGHAI TIANMA MICRO-ELECTRONICS Corporation.



6.2 Power off Sequence

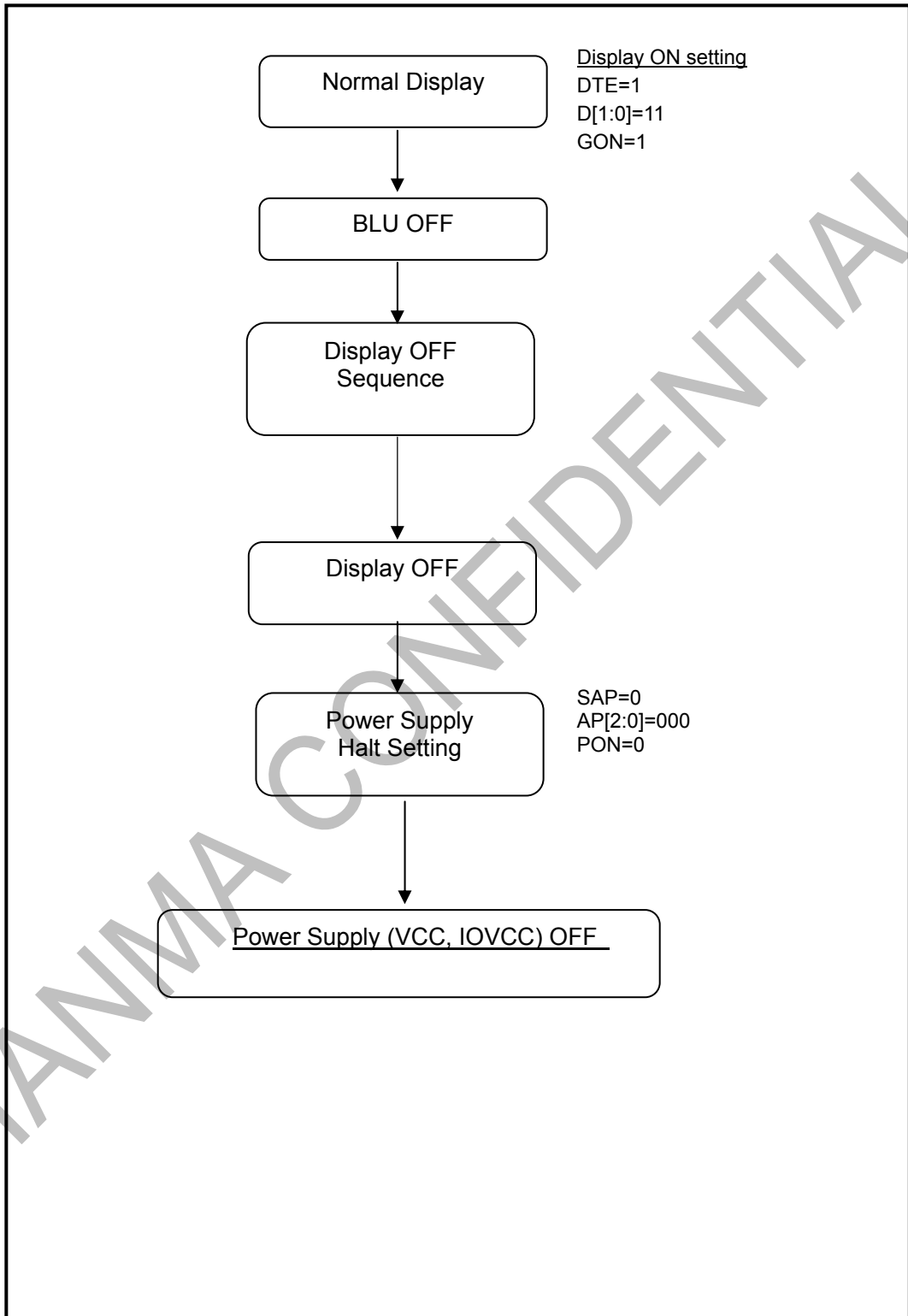

The information contained herein is the exclusive property of SHANGHAI TIANMA MICRO-ELECTRONICS Corporation, and shall not be distributed, reproduced, or disclosed in whole or in part without prior written permission of SHANGHAI TIANMA MICRO-ELECTRONICS Corporation.



7 Optical Characteristics

Ta=25°C

Item	Symbol	Condition	Min	Typ	Max	Unit	Remark
View Angles	θT	$CR \geq 10$	60	70	-	Degree	Note 2
	θB		60	70	-		
	θL		50	60	-		
	θR		60	70	-		
Contrast Ratio	CR	$\theta=0^\circ$	400	500	-		Note1 Note3
Response Time	T _{ON}	25°C	-	20	30	ms	Note1 Note4
	T _{OFF}						
Chromaticity	White	Backlight is on	x	0.255	0.305	0.355	Note5, Note1
			y	0.267	0.317	0.367	
	Red		x	0.538	0.588	0.638	
			y	0.289	0.339	0.389	
	Green		x	0.289	0.339	0.389	
			y	0.523	0.573	0.623	
	Blue		x	0.116	0.166	0.216	
			y	0.038	0.088	0.138	
Uniformity	U		75	80	-	%	Note1 Note6
NTSC			-	50	-	%	Note 5
Luminance	L		180	200	-	cd/m ²	Note1 Note7

Test Conditions:

1. $V_F = 3.2V$, $I_F = 15mA$ (for each LED), the ambient temperature is 25°C.
2. The test systems refer to Note 1 and Note 2.

The information contained herein is the exclusive property of SHANGHAI TIANMA MICRO-ELECTRONICS Corporation, and shall not be distributed, reproduced, or disclosed in whole or in part without prior written permission of SHANGHAI TIANMA MICRO-ELECTRONICS Corporation.



Note 1: Definition of optical measurement system.

The optical characteristics should be measured in dark room. After 5 minutes operation, the optical properties are measured at the center point of the LCD screen. All input terminals LCD panel must be ground when measuring the center area of the panel.

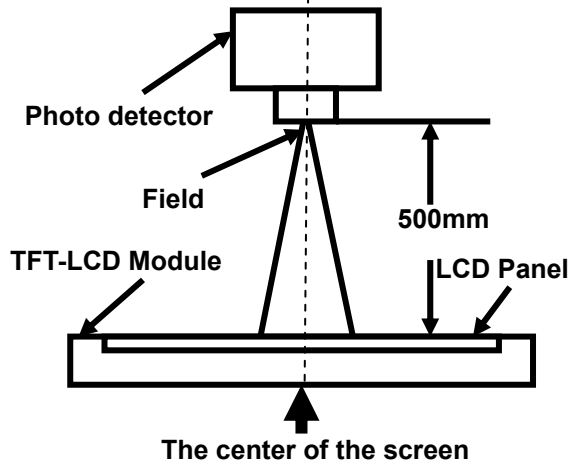

Item	Photo detector	Field
Contrast Ratio	SR-3A	1°
Luminance		
Chromaticity		
Lum Uniformity		
Response Time	BM-7A	2°

Note 2: Definition of viewing angle range and measurement system.

viewing angle is measured at the center point of the LCD by CONOSCOPE(ergo-80).

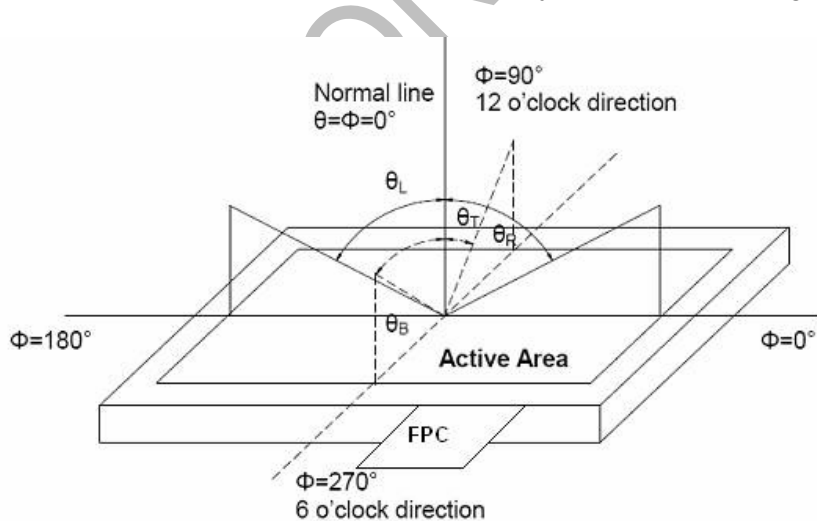

Note 3: Definition of contrast ratio

$$\text{Contrast ratio (CR)} = \frac{\text{Luminance measured when LCD is on the "White" state}}{\text{Luminance measured when LCD is on the "Black" state}}$$

“White state “:The state is that the LCD should be driven by V_{white}.

“Black state”: The state is that the LCD should be driven by V_{black}.



Vwhite: To be determined Vblack: To be determined.

Note 4: Definition of Response time

The response time is defined as the LCD optical switching time interval between “White” state and “Black” state. Rise time (TON) is the time between photo detector output intensity changed from 90% to 10%. And fall time (TOFF) is the time between photo detector output intensity changed from 10% to 90%.

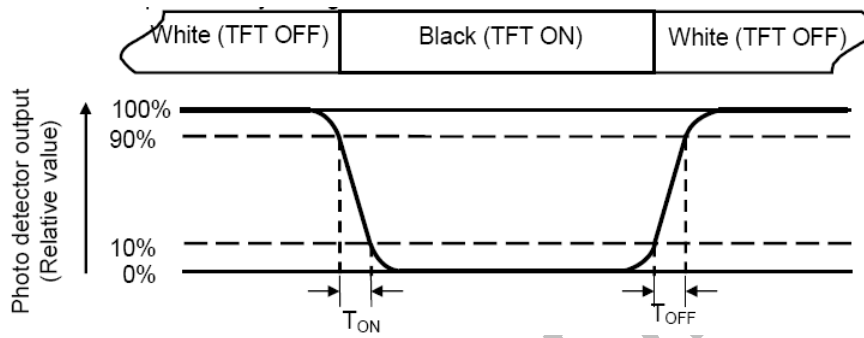

Note 5: Definition of color chromaticity (CIE1931)

Color coordinates measured at center point of LCD.

Note 6: Definition of Luminance Uniformity

Active area is divided into 9 measuring areas (Refer Fig. 2). Every measuring point is placed at the center of each measuring area.

Luminance Uniformity(U) = Lmin/ Lmax

L-----Active area length W----- Active area width

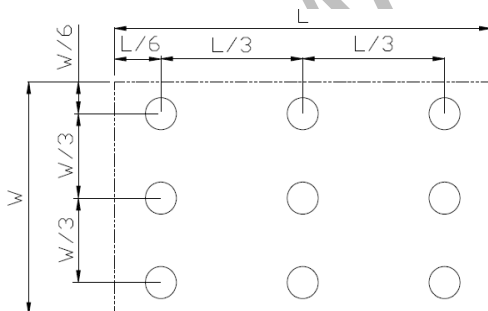

Lmax: The measured maximum luminance of all measurement position.

Lmin: The measured minimum luminance of all measurement position.

Note 7: Definition of Luminance:

Measure the luminance of white state at center point.

The information contained herein is the exclusive property of SHANGHAI TIANMA MICRO-ELECTRONICS Corporation, and shall not be distributed, reproduced, or disclosed in whole or in part without prior written permission of SHANGHAI TIANMA MICRO-ELECTRONICS Corporation.



8 Environmental / Reliability Tests

No	Test Item	Condition	Remarks
1	High Temperature Operation	Ts=+70°C, 240hrs	Note1 IEC60068-2-2,GB2423.2—89
2	Low Temperature Operation	Ta=-20°C, 240hrs	IEC60068-2-1 GB2423.1—89
3	High Temperature Storage	Ta=+80°C, 240hrs	IEC60068-2-2 GB2423.2—89
4	Low Temperature Storage	Ta=-30°C, 240hrs	IEC60068-2-1 GB2423.1—89
5	High Temperature & High Humidity Storage	Ta=+60°C, 90% RH 240 hours	Note2 IEC60068-2-3 GB/T2423.3—2006
6	Thermal Shock (Non-operation)	-30°C 30 min~+80°C 30 min, Change time:5min, 20 Cycles	Start with cold temperature, End with high temperature, IEC60068-2-14,GB2423.22—87
7	Electro Static Discharge (Operation)	C=150pF, R=330Ω, 5points/panel Air:±8KV, 5times; Contact:±4KV, 5 times; (Environment: 15°C ~ 35°C, 30% ~ 60%, 86Kpa ~ 106Kpa)	IEC61000-4-2 GB/T17626.2—1998
8	Vibration (Non-operation)	Frequency range:10~55Hz, Stroke:1.5mm Sweep:10Hz~55Hz~10Hz 2 hours for each direction of X.Y.Z. (6 hours for total)(Package condition)	IEC60068-2-6 GB/T2423.10—1995
9	Shock (Non-operation)	60G 6ms, ±X,±Y,±Z 3times, for each direction	IEC60068-2-27 GB/T2423.5—1995
10	Package Drop Test	Height:80 cm, 1 corner, 3 edges, 6 surfaces	IEC60068-2-32 GB/T2423.8—1995

Note: Ts is the temperature of panel's surface.

Ta is the ambient temperature of sample.



9 Mechanical Drawing

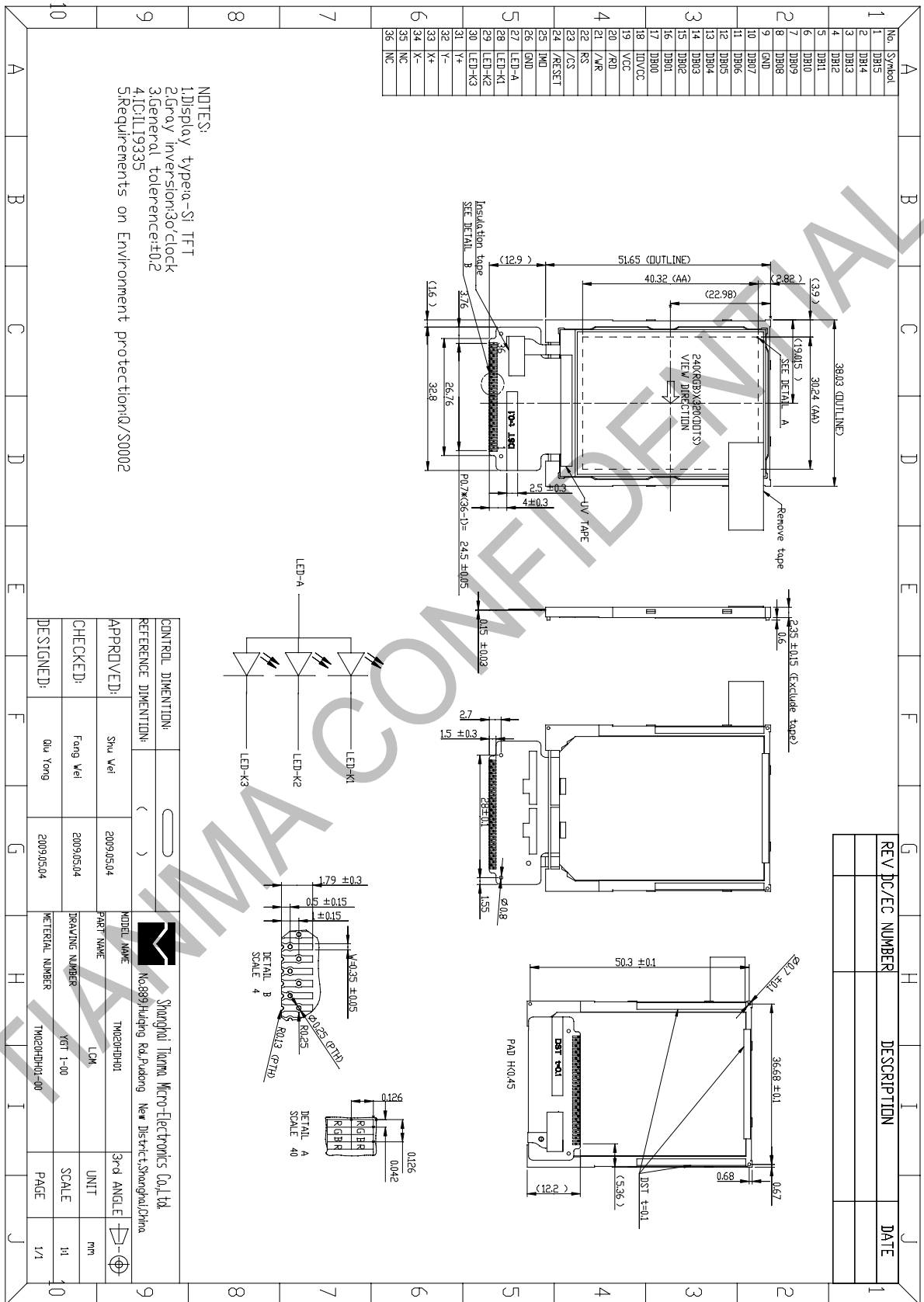

The information contained herein is the exclusive property of SHANGHAI TIANMA MICRO-ELECTRONICS Corporation, and shall not be distributed, reproduced, or disclosed in whole or in part without prior written permission of SHANGHAI TIANMA MICRO-ELECTRONICS Corporation.



10 Packing Drawing

No	Item	Model (Material)	Dimensions (mm)	Unit Weight (Kg)	Quantity	Remark	
1	LCM Module	TM020HDH01	38.03x51.65x2.35	TBD	672		
2	Tray	PET(Transmit)	315x247x10.3	0.087	48	Anti-static	
3	EPE	EPE	315x247x5	0.009	12		
4	Anti-static Bag	PE	327x440	0.021	6		
5	Box	Corrugated Paper	34x260x70	0.227	6		
6	Desiccant	Desiccant	45X50	0.0035	12		
7	Carton	Corrugated Paper	544x365x250	1.01	1		
8	Total Weight (Kg)	TBD					

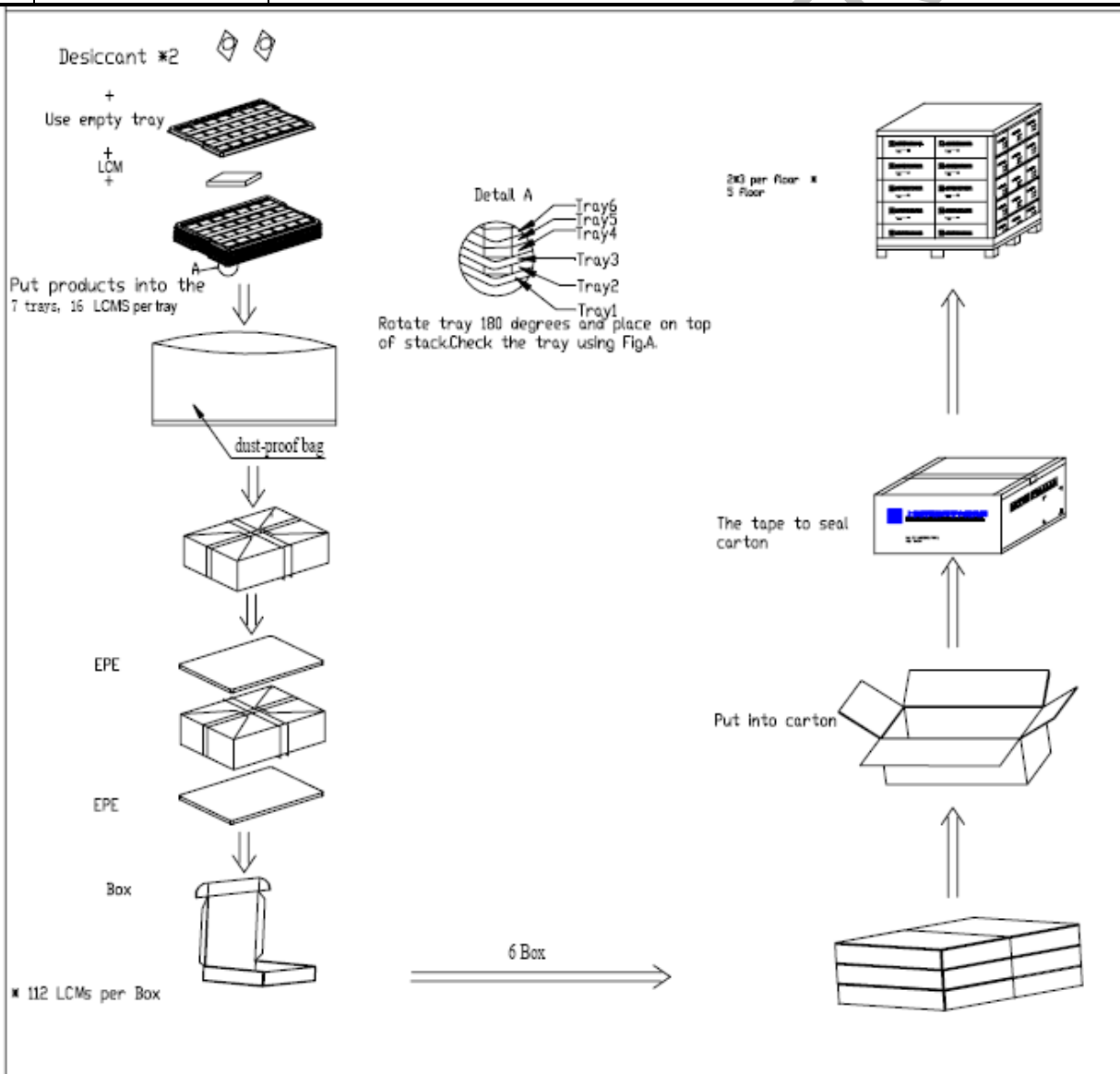

The information contained herein is the exclusive property of SHANGHAI TIANMA MICRO-ELECTRONICS Corporation, and shall not be distributed, reproduced, or disclosed in whole or in part without prior written permission of SHANGHAI TIANMA MICRO-ELECTRONICS Corporation.



11 Precautions for Use of LCD Modules

11.1 Handling Precautions

11.1.1 The display panel is made of glass. Do not subject it to a mechanical shock by dropping it from a high place, etc.

11.1.2 If the display panel is damaged and the liquid crystal substance inside it leaks out, be sure not to get any in your mouth, if the substance comes into contact with your skin or clothes, promptly wash it off using soap and water.

11.1.3 Do not apply excessive force to the display surface or the adjoining areas since this may cause the color tone to vary.

11.1.4 The polarizer covering the display surface of the LCD module is soft and easily scratched. Handle this polarizer carefully.

11.1.5 If the display surface is contaminated, breathe on the surface and gently wipe it with a soft dry cloth. If still not completely clear, moisten cloth with one of the following solvents:

- Isopropyl alcohol
- Ethyl alcohol

Solvents other than those mentioned above may damage the polarizer. Especially, do not use the following:

- Water
- Ketone
- Aromatic solvents

11.1.6 Do not attempt to disassemble the LCD Module.

11.1.7 If the logic circuit power is off, do not apply the input signals.

11.1.8 To prevent destruction of the elements by static electricity, be careful to maintain an optimum work environment.

11.1.8.1 Be sure to ground the body when handling the LCD Modules.

11.1.8.2 Tools required for assembly, such as soldering irons, must be properly ground.

11.1.8.3 To reduce the amount of static electricity generated, do not conduct assembly and other work under dry conditions.

11.1.8.4 The LCD Module is coated with a film to protect the display surface. Be care when peeling off this protective film since static electricity may be generated.

11.2 Storage precautions

11.2.1 When storing the LCD modules, avoid exposure to direct sunlight or to the light of fluorescent lamps.

11.2.2 The LCD modules should be stored under the storage temperature range. If the LCD modules will be stored for a long time, the recommend condition is:

Temperature : 0°C ~ 40°C Relatively humidity: ≤80%

11.2.3 The LCD modules should be stored in the room without acid, alkali and harmful gas.

11.3 Transportation Precautions:

The LCD modules should be no falling and violent shocking during transportation, and also should avoid excessive press, water, damp and sunshine.